

Impact of Charging Rate and State of Charge on Electric Aircraft Battery Degradation Using a Multi-Domain Model with Realistic Southeastern U.S. Flight Paths

Korebami O. Adebajo^{*}, George Anthony[†], Jarett Peskar[‡], Dr. Austin R.J. Downey[§], Dr. Yuche Chen[¶], and Dr. Chao Hu^{||}

Electrifying transportation is a growing initiative among governments and therefore companies seeking alternatives to carbon-intensive vehicles. While the automotive industry's demand for electric vehicles increases, sectors like aerospace are also exploring electric applications. However, relying on batteries as the primary power source presents challenges such as high costs, limited availability of raw materials, and safety concerns. Additionally, inconsistent battery usage leads to varying rates of battery degradation, posing further difficulties. This study aims to understand battery degradation in electric aircraft subjected to different battery charging parameters using multi-domain modeling. The long-term goal is to facilitate the commercialization of electric aircraft by making them more economically viable while considering real-world constraints. An open-source multi-domain model built in the MATLAB-Simscape environment provides a robust platform to simulate different flight profiles and track battery degradation in terms of battery capacity. To analyze battery behavior under various conditions, we examined different flight routes characterized by distinct load profiles with varying charging parameters. The analysis focuses on a battery pack composed of Lithium Nickel Manganese Cobalt cells with a capacity of 260 Ah at 418 V; resulting in a nominal pack capacity of 109 kWh. We evaluated the effects of battery degradation across three flight routes in the southeastern United States under two charging rates: 1.5C and 2C. Results show that charging at 1.5C degrades the battery significantly less than charging at 2C. Additionally, starting flights with an initial state of charge of 80% instead of 100% further reduced battery degradation across all flight routes. Variations in flight route length were found to have a minimum effect. By incorporating battery degradation into smarter route planning, the study offers pathways to improve the sustainability and economic viability of electric aviation. This suggests that careful selection of battery charging parameters can mitigate some of the current limitations of electric aircraft.

I. Nomenclature

<i>SOC</i>	=	State of Charge
<i>RUL</i>	=	Remaining Useful Life
<i>SOH</i>	=	State of Health
<i>PMSM</i>	=	Permanent Magnet Synchronous Motor
<i>PID</i>	=	Proportional Integral Derivative
<i>NMC</i>	=	Lithium Nickel Manganese Cobalt Oxide
<i>C</i> -rate	=	Charge/discharge rate relative to battery capacity
<i>DC</i>	=	Direct Current
<i>AC</i>	=	Alternating Current

^{*}Undergraduate Research Assistant, Department of Mechanical Engineering, University of South Carolina, Columbia, SC 29208, USA.

[†]Graduate Student, University of South Carolina Department of Mechanical Engineering, University of South Carolina, Columbia, SC 29208, USA.

[‡]Graduate Research Assistant, Department of Mechanical Engineering, University of South Carolina, Columbia, SC 29208, USA.

[§]Associate Professor, AIAA Member, Department of Mechanical Engineering, Department of Civil, and Environmental Engineering, University of South Carolina, Columbia, SC 29208, USA, Contact Author austindowney@sc.edu

[¶]Assistant Professor, Department of Civil and Environmental Engineering, University of South Carolina, Columbia, SC 29208, USA.

^{||}Associate Professor, Department of Mechanical Engineering, University of Connecticut, Storrs, CT 06269, USA.

II. Introduction

Electric aircraft are undergoing significant development and investment as efforts intensify to reduce carbon footprints and adopt more sustainable energy sources, making them a prime focus for transitioning to electric propulsion. [1]. Since the transportation sector is a significant generator of carbon emissions, tackling sustainable avenues would go a long way. However, the transition to electric aircraft comes with its own set of challenges, most notably in the realm of battery technology [2].

The use of battery cells for energy-intensive applications, such as aerospace, present several challenges. A few of these are finding the balance between energy density and its weight, limited availability of raw materials, cell production, safety, and devising optimal usage strategies for aircraft that take account of battery degradation [3]. Companies are developing electric aircraft for private and commercial use, primarily focusing on small planes designed to carry 2-10 persons. Examples include aircraft manufactured by Pipistrel and Joby Aviation. Currently, small aircraft are the most economical for electric propulsion [4].

There is a need to study and optimize aircraft operations to mitigate battery degradation. This is done to provide better economics for electric aircraft, thereby accelerating their adoption [5]. Research in this field involves predictive battery assessment under various operating conditions. This includes using multi-domain software to track battery cell behavior under unique conditions such as temperature, load conditions, aircraft types, and cell composition [6]. The limited range of electric aircraft requires careful management of energy storage resources to provide optimal long-term performance.

In this work, a multi-domain model of a 6-passenger aircraft is developed and used to investigate battery aging over three realistic flight paths in the Southeastern United States. The model provides key insights on the degradation effects of both flight profiles and charging rates. The contributions of this work are twofold. First, an open-source multi-domain model of a 6-passenger electric aircraft was developed using MATLAB-Simscape [7]. This comprehensive model integrates electrical, mechanical, and thermal domains, including state-of-charge (SOC) and remaining useful life (RUL) estimators, providing a versatile tool for simulating and analyzing the performance of electric aircraft under various operating conditions. Second, the model was utilized to investigate the effect of charging speeds on battery degradation, considering three realistic flight paths in the Southeastern United States and two starting SOC values (100% and 80%). The analysis demonstrates how different charging rates (1.5C and 2.0C) and SOC ranges impact battery life, offering insights into optimal battery management strategies that can enhance the economic viability of electric aircraft.

III. Methodology

This section outlines the methodology used for this paper. First, the design parameters for a six-passenger electric aircraft are chosen and built into a multi-domain model of said aircraft. Then the three realistic flight routes in the Southeast United States considered for this work are introduced to the model. Finally, this work explores the aircraft's operational charging parameters in relation to battery usage.

A. Battery-electric Aircraft

The multi-domain model in this work was developed around the Cessna 206H Stationair plane, reconfigured to operate on a battery-electric powertrain rather than conventional fuel. Table 1 reports the aircraft's parameters and selected specifications. The battery pack used in the simulation has a capacity of 260 Ah consisting of NMC cells, with a total pack voltage of 418 V, representing a realistic configuration for electric aviation applications.

Table 1 Chosen electric aircraft parameters and specifications.

Parameter	Specifications
Passenger seats	6
Battery capacity (Ah)	260
Energy capacity (kWh)	109
Horsepower	300
Max speed (km/hr)	280
Cruise speed (km/hr)	262

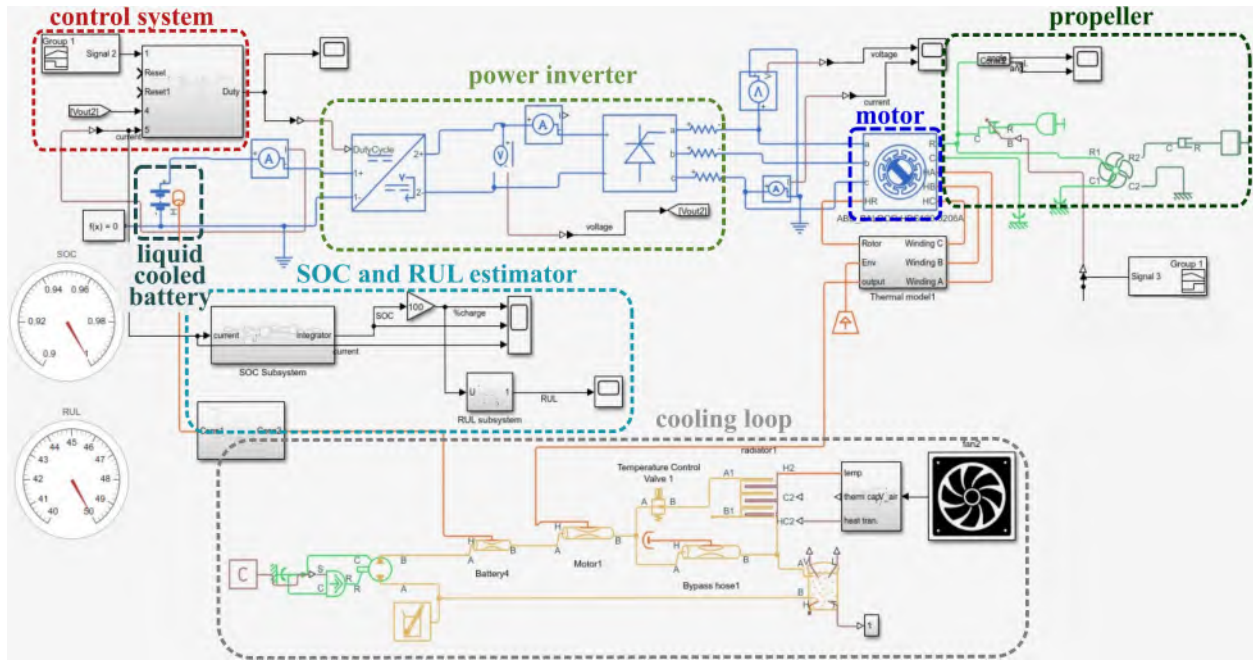

Fig. 1 The developed open-source multi-domain model with key sub-components

The open-source multi-domain model, shown in Fig. 1, was created using MATLAB-Simscape allowing for proper integration of the different aspects of the aircraft. The multi-domain model is available through a public repository [7]. The model includes three major domains: Electrical, Mechanical, and Thermal. The electrical domain contains the battery, DC-DC converter, inverter, electric motor, SOC, and RUL subsystems, which are crucial for monitoring the battery’s performance over time. The mechanical domain represents the propeller and its casing, allowing control over the load profile based on historical flight routes taken from publicly available data [8]. The thermal domain encompasses both the battery and motor, connected to a cooling loop consisting of a radiator and pump. These three domains enable comprehensive monitoring and simulation of various parts of the electric aircraft.

1. Electrical Domain

The electrical domain houses the battery, power inverting unit, the Permanent Magnet Synchronous Motor (PMSM), and the control system. The base of the model is the battery with a nominal voltage of 418 V and a 260 Ah capacity giving approximately 109 kWh of energy. The control subsystem controls the DC voltage input to the power inverter through a series of proportional Integral (PI) controllers to compensate for errors with voltage and current with the values for K_p and K_i previously determined for the more efficient output signal. The desired voltage output is set with the *Signal Builder* block which plays the role of inputs received from the pilot during a flight. The output is connected to the DC-DC converter serving as a buck-boost converter.

The power inverter is the core of the electrical domain; consisting of the DC-DC converter to the DC-AC inverter and is located near the top-center of the model, as shown in Fig. 1. The converter is set to operate as an ideal buck-boost converter at 95% efficiency setting. After this block, a voltage sensor is set in place as feedback to the control system and a connection to the inverter. A PMSM is chosen because it is most similar to the motors used in the Pipistrel Velis Electro and other electric aircraft and can be adapted from a variety of motors in the Simscape library.

2. Mechanical Domain

The mechanical domain is made up of only a few components as shown in Fig. 1. The mechanical parts of the aircraft are represented by the inertia and load blocks. A propeller is added to monitor both the power output of the aircraft and to couple the model to the flight conditions.



Fig. 2 Flight paths tested through the model with their respective flight times.

3. Thermal Domain

The thermal system is primarily the cooling system and its supporting components. Thermal outputs of both the battery and PMSM are injected into the cooling loop powered by an electric pump. The order of the loop is as follows; Tank → Electric pump → Heat inlet piping → Temperature controlled valve → Radiator cooling → Bypass pipe → Tank. The temperature of both the battery and PMSM can be managed to prevent overheating throughout the simulation.

4. SOC and RUL Estimators

Coulomb counting was used in the SOC estimator to calculate battery discharge and charge after each flight. This was configured with Simscape blocks to accurately track the battery’s charge state in real-time during the simulation. The RUL estimator was based on previous testing across different SOC ranges. The varying depth of discharges determined the degradation rate, which was used to predict the RUL of the battery. The method reported by Olmos et al. was used for RUL prediction [9].

B. Modeled Flight Paths

To assess the effect of load profiles specific to different flight paths on battery degradation, three realistic routes in the Southeastern United States were considered, particularly in South Carolina, North Carolina, and Georgia, as shown in Fig. 2. The flight paths examined were between Greenville, South Carolina, and Augusta, Georgia (a 1-hour flight); Augusta, Georgia, and Myrtle Beach, South Carolina (1 hour and 20 minutes); and Myrtle Beach, South Carolina, and Charlotte, North Carolina (1 hour and 23 minutes). Each of these routes demonstrated distinct levels of battery degradation, influenced by the varying C-rates associated with the flights. Flight profiles were obtained from publicly available data [8] and converted into load profiles, which are reported in Fig. 3.

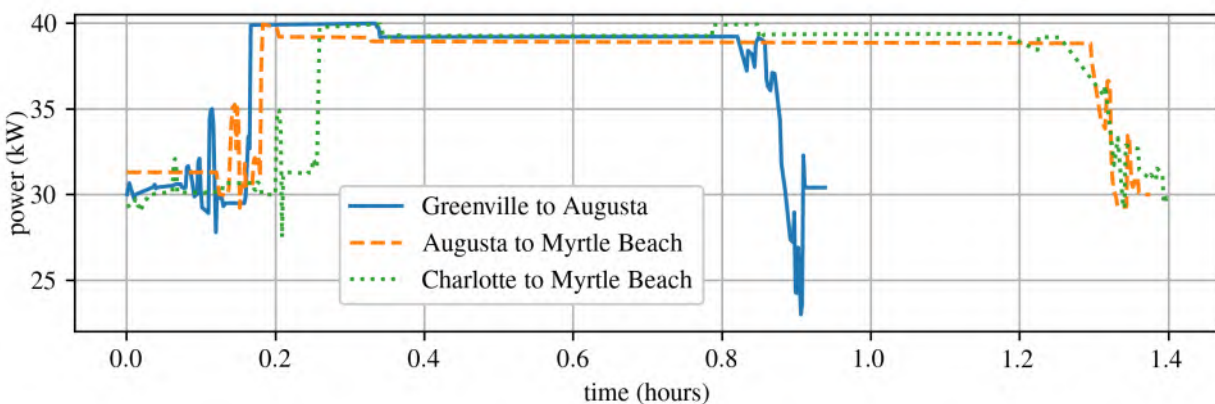

Fig. 3 Load profiles for the three flight routes considered in this work.

C. Aircraft Operational Parameters Related to Battery Usage

The effects of starting flights with two different initial SOC's — 100% and 80% — on battery degradation were examined. Testing different initial SOC levels is important because operating at a lower maximum SOC can reduce stress on the battery, potentially extending its RUL. Additionally, the degradation caused by different charging rates of 1.5C and 2.0C was observed. Testing various charging rates is crucial because higher charging speeds can accelerate battery degradation due to increased thermal and electrochemical stress. Understanding the impact of these factors helps in developing optimal charging strategies that balance operational efficiency with battery longevity in electric aircraft.

IV. Results

Figs. 4-6 present the results of our investigation. Results in Fig. 4 show that battery degradation was most severe for the route from Augusta, Georgia to Myrtle Beach, South Carolina. This is expected since based on Fig. 2, this route resulted in the aircraft being in the air for the longest amount of time. However, it is noteworthy that the battery degraded substantially less when it was only charged to 80% before takeoff, as shown in Fig. 4(b).

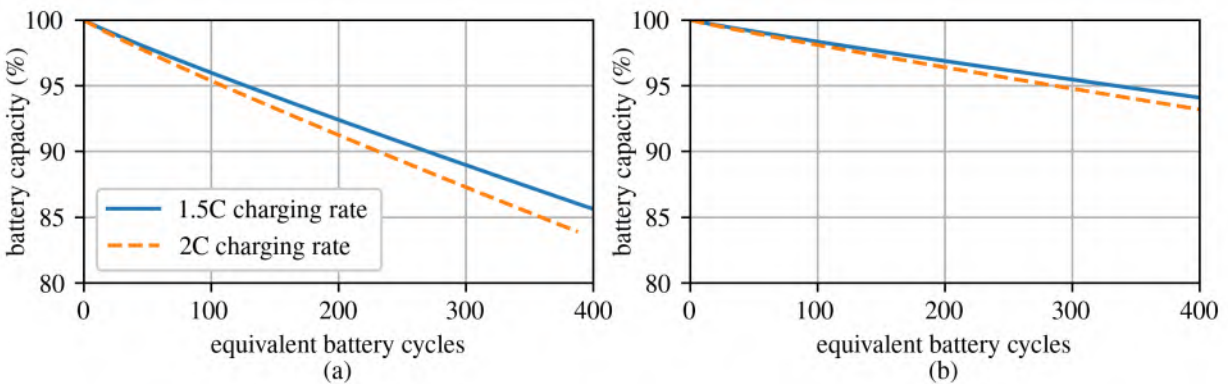

Fig. 4 Results for Augusta, Georgia to Myrtle Beach, South Carolina, showing battery degradation based off two different charging rates with a starting SOC of: (a) 100% for each flight and; (b) 80% for each flight.

Fig. 5 reports the battery degradation results for the flight from Charlotte, North Carolina to Myrtle Beach, South Carolina. These results are similar to those of the Augusta to Myrtle Beach route, as expected since the flight time is similar but slightly shorter. As before, the battery degraded substantially less when it was only charged to 80% before takeoff, as shown in Fig. 5(b).

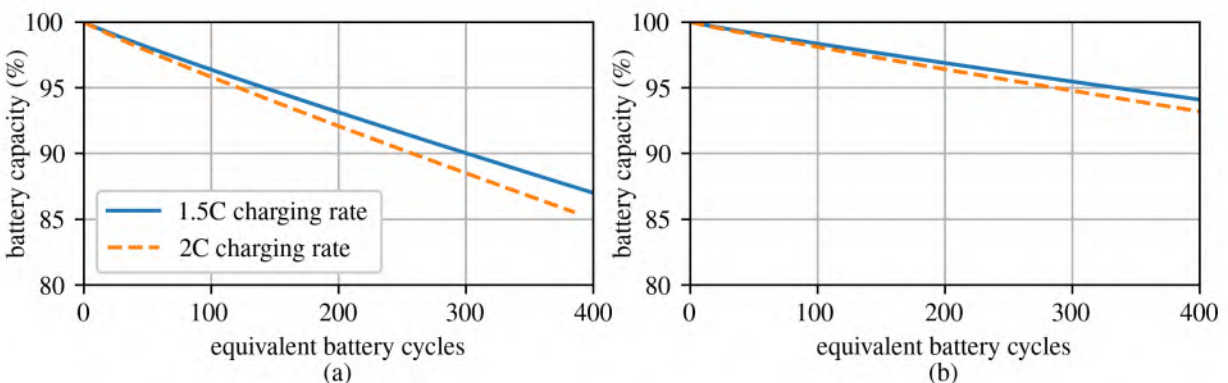

Fig. 5 Results for Charlotte, North Carolina to Myrtle Beach, South Carolina, showing battery degradation based off two different charging rates with a starting SOC of: (a) 100% for each flight and; (b) 80% for each flight.

The Greenville to Augusta route is the shortest, as shown in Fig. 2, and it results in the least amount of battery degradation. Specifically, only 10% of the battery capacity is lost over 400 cycles when charged at 1.5C and to 100% SOC before takeoff. Again, the results in Fig. 6(b) show that battery degradation can be significantly reduced if the battery is only charged to 80% SOC before takeoff.

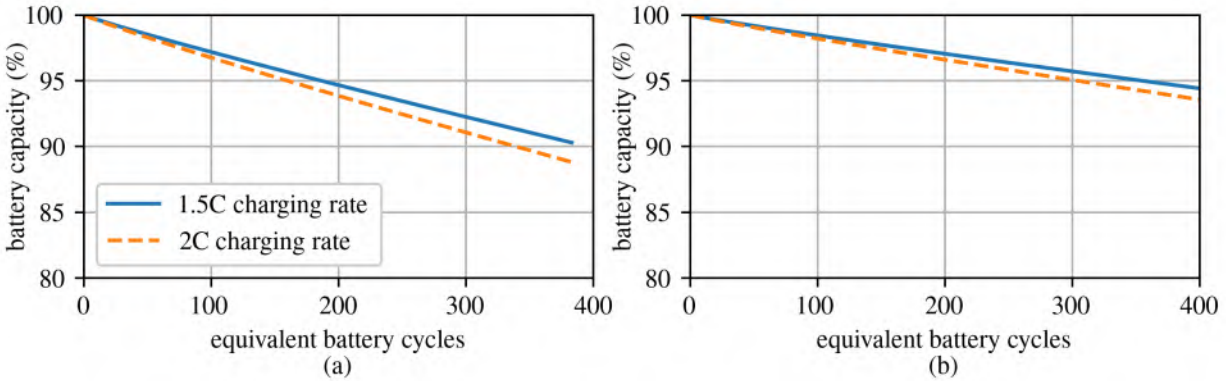

Fig. 6 Results for Greenville, South Carolina to Augusta, Georgia, showing battery degradation based off two different charging rates with a starting SOC of: (a) 100% for each flight and; (b) 80% for each flight.

The results of this study reveals that charging practices have a more significant impact on battery degradation than flight length in electric aircraft. Charging to 100% SOC and using fast charging rates substantially accelerate battery wear. Starting flights at 80% SOC and employing slower charging rates consistently result in less battery degradation, regardless of flight duration. While longer flights do consume more energy, their effect on battery health is less pronounced compared to the detrimental impact of high initial SOC levels and rapid charging. Therefore, to mitigate battery degradation and enhance the economic viability of electric aircraft, it's crucial to adopt charging strategies that limit initial SOC and utilize slower charging rates.

V. Conclusions

This work presents the development of an open-source multi-domain model of a 6-passenger electric aircraft and used it to investigate the effects of charging practices on battery degradation across three realistic flight paths in the Southeastern United States. The findings indicate that charging to a full 100% SOC and using faster charging rates significantly accelerate battery degradation, while starting flights at 80% SOC and employing slower charging rates markedly reduce battery wear, regardless of flight duration. These results suggest that optimizing charging strategies, by limiting initial SOC and reducing charging speeds, can enhance the economic viability and operational lifespan of electric aircraft batteries. Future work will focus on integrating more flight scenarios and exploring additional battery management techniques to further improve the sustainability of electric aviation.

Acknowledgments

This material is based in part upon work supported by the Air Force Office of Scientific Research (AFOSR) through award no. FA9550-21-1-0083. This work is also partly supported by the National Science Foundation (NSF) grant number 2237696. This project is also partially supported by the University of South Carolina Office of Undergraduate Research through the Magellan Scholar Program. Any opinions, findings, conclusions, or recommendations expressed in this material are those of the authors and do not necessarily reflect the views of the National Science Foundation, the United States Air Force, or the University of South Carolina.

References

- [1] Schwab, A., Thomas, A., Bennett, J., Robertson, E., and Cary, S., *Electrification of Aircraft: Challenges, Barriers, and Potential Impacts*, 2021. <https://doi.org/10.2172/1827628>.
- [2] Viswanathan, V., Epstein, A. H., Chiang, Y.-M., Takeuchi, E., Bradley, M., Langford, J., and Winter, M., "Author Correction:

The challenges and opportunities of battery-powered flight,” *Nature*, Vol. 603, No. 7903, 2022, pp. E30–E30. <https://doi.org/10.1038/s41586-022-04612-5>.

- [3] Saxena, S., Hendricks, C., and Pecht, M., “Cycle life testing and modeling of graphite/LiCoO₂ cells under different state of charge ranges,” *Journal of Power Sources*, Vol. 327, 2016, pp. 394–400. <https://doi.org/10.1016/j.jpowsour.2016.07.057>.
- [4] Adu-Gyamfi, B. A., and Good, C., “Electric aviation: A review of concepts and enabling technologies,” *Transportation Engineering*, Vol. 9, 2022, p. 100134. <https://doi.org/10.1016/j.treng.2022.100134>.
- [5] Anthony, G., Peskar, J., Downey, A. R., and Booth, K., “Extending Battery Life via Load Sharing in Electric Aircraft,” *AIAA SCITECH 2024 Forum*, American Institute of Aeronautics and Astronautics, 2024. <https://doi.org/10.2514/6.2024-2154>.
- [6] Kim, G.-H., Smith, K., Lee, K.-J., Santhanagopalan, S., and Pesaran, A., “Multi-Domain Modeling of Lithium-Ion Batteries Encompassing Multi-Physics in Varied Length Scales,” *Journal of The Electrochemical Society*, Vol. 158, No. 8, 2011, p. A955. <https://doi.org/10.1149/1.3597614>.
- [7] ARTS-Lab, “Multi-domain Powertrain Model of Electric Light Aircraft,” GitHub, 2024. URL <https://github.com/ARTS-Laboratory/Multi-domain-Powertrain-Model-of-Electric-Light-Aircraft>.
- [8] Flightdata, “Load profile,” 2024. URL www.flightdata.com/flight/774549.
- [9] Josu, O., Iñigo, G., Andoni, S.-d.-I., Xabier, L., Txomin, N., and Iosu, A., “Modelling the cycling degradation of Li-ion batteries: Chemistry influenced stress factors,” *Journal of Energy Storage*, Vol. 40, 2021. <https://doi.org/10.1016/j.est.2021.102765>.