

Multi-Model Data Assimilation for Structures

Austin Downey¹, Jason Smith¹, Alysson Mondoro², Benjamin Grisso²

Department of Mechanical Engineering, University of South Carolina
Naval Surface Warfare Center, Carderock Division, Code 65



Digital Twins

What constitutes a digital twin?

Does a Response Amplitude Operator (RAO) count?

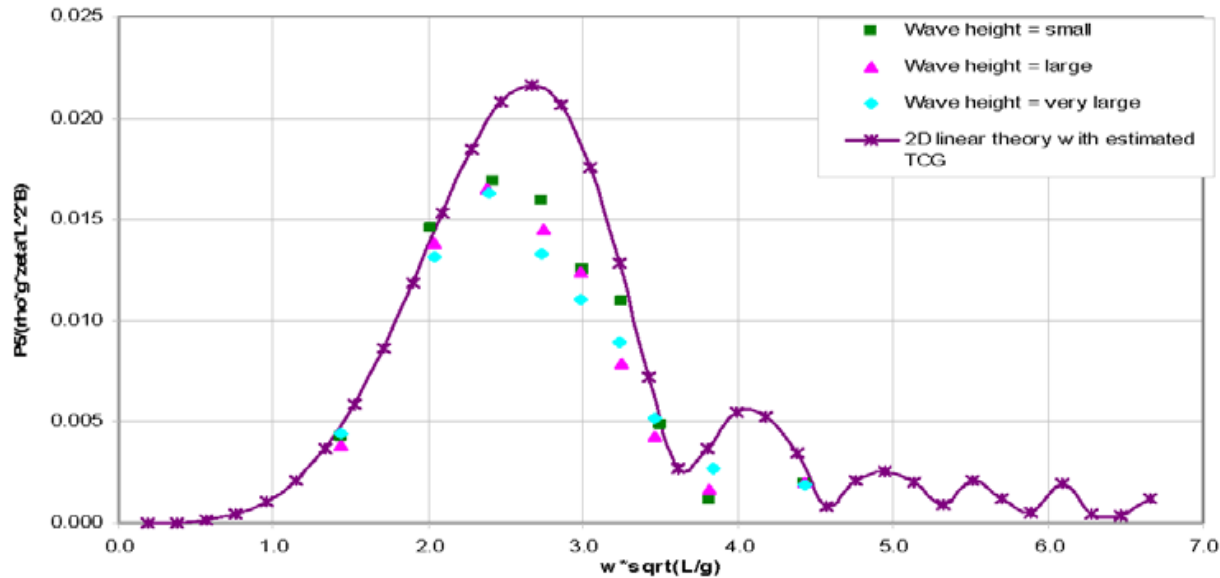

NSWCCD Model 5415 Vertical Bending Moment Response Amplitude Operator

From SNAME Ship Structure Committee SSC-459, "RELIABILITY-BASED PERFORMANCE ASSESSMENT OF DAMAGED SHIPS"

Does it need to model everything?

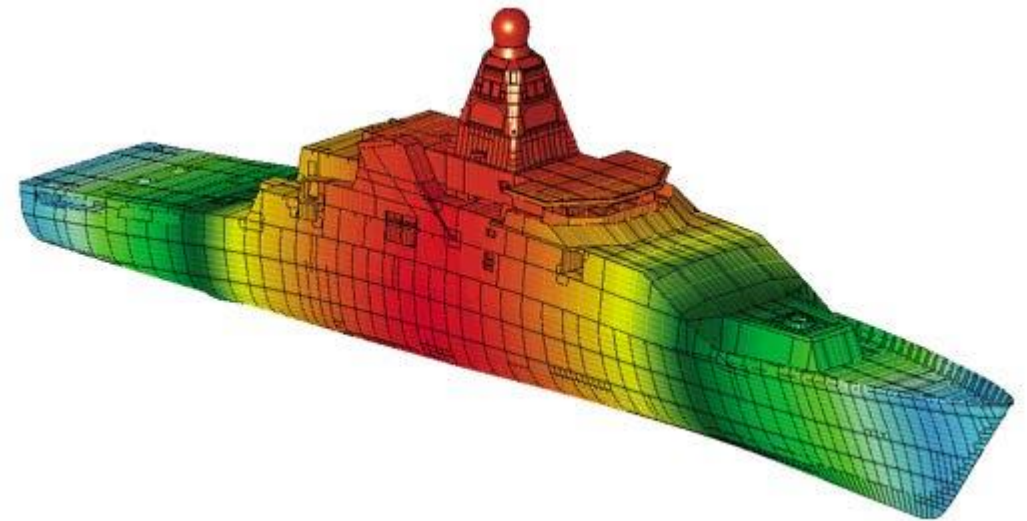

MORAIS, D.; WALDIE, M.; LARKINS, D. (2018), *The Digital Twin Journey*, 17th Conf. Computer and IT Appl. Maritime Ind., Pavone, pp.98-105

How does the Navy envision digital twins?

A digital twin is ultimately a systems of systems model that enables greater insight into the platform

Digital Twin is a continuous blending of data, physics-based models, and machine learning combined with our best knowledge of the ocean battlespace to forecast platform performance. These insights improve situational awareness and enables a user to readily identify optimum **actionable decisions.**

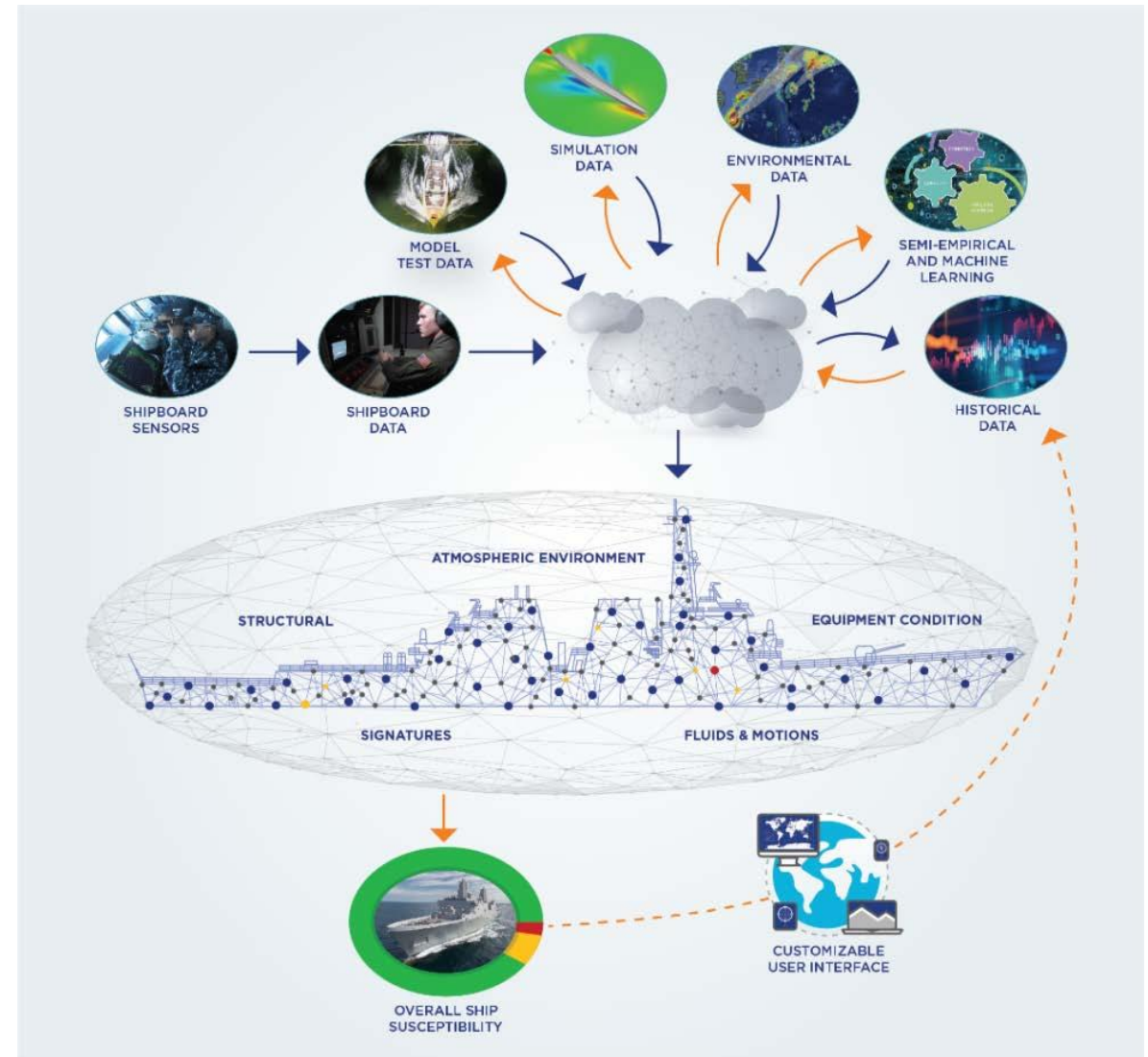

Are we overselling the capability?

- We have been talking about this for years

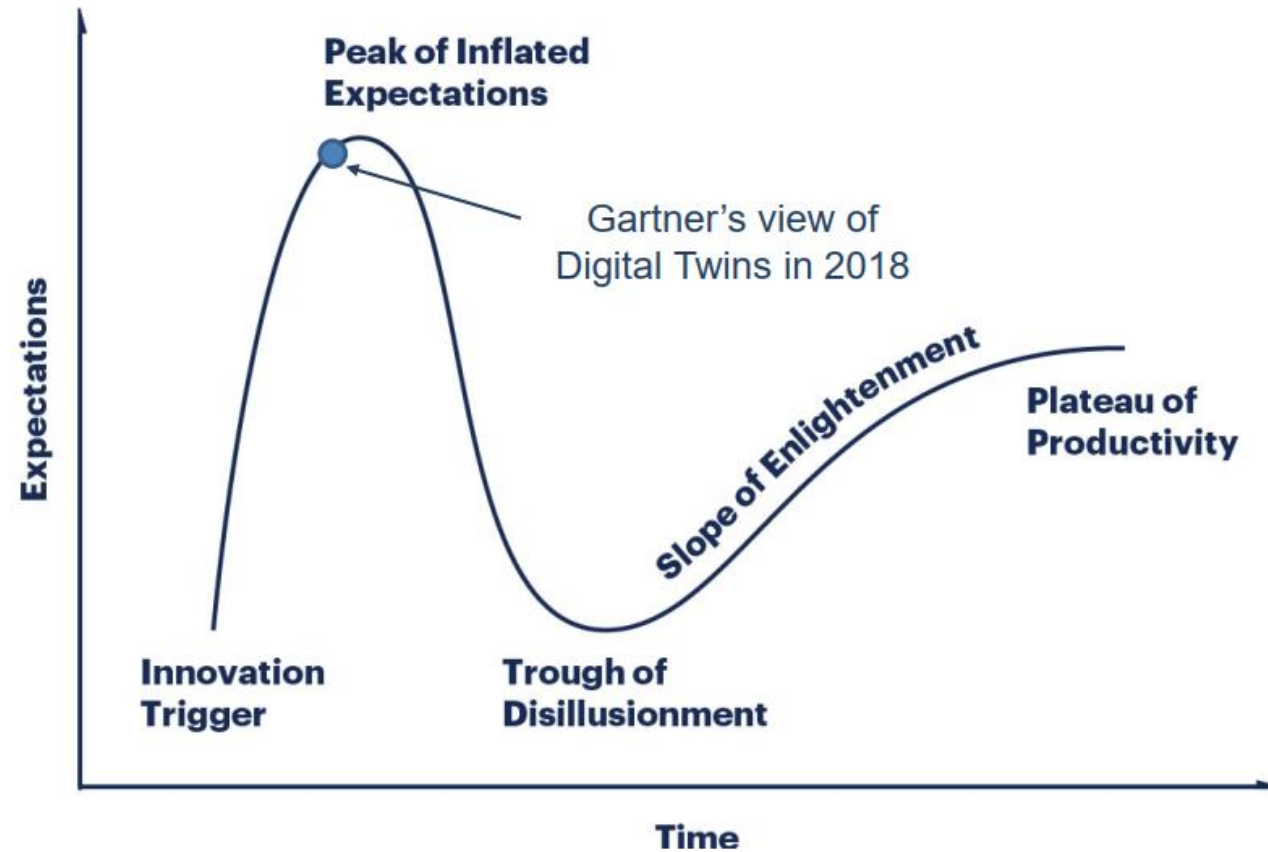

What can digital twins provide?

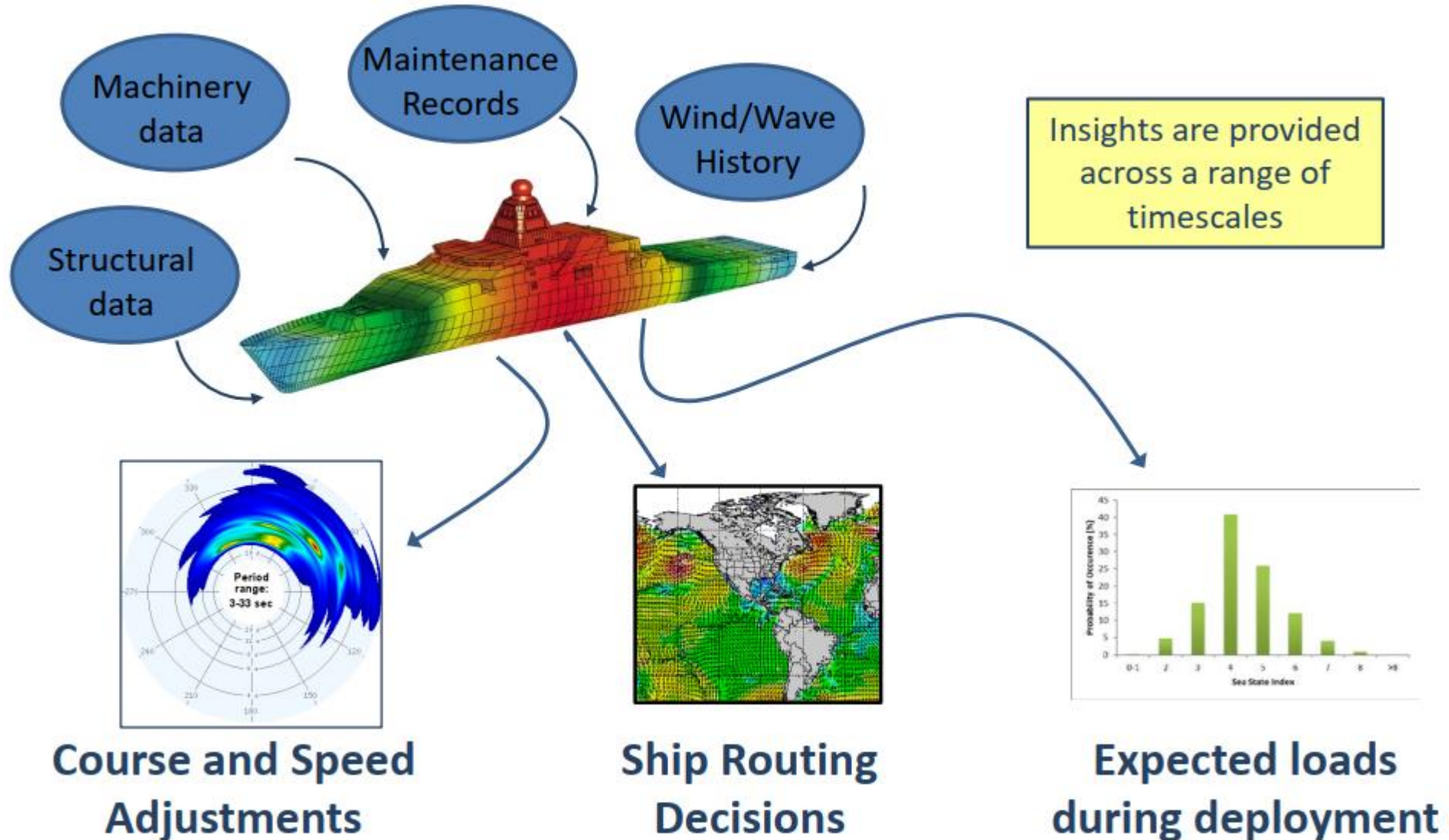

Start with Structural Health Monitoring

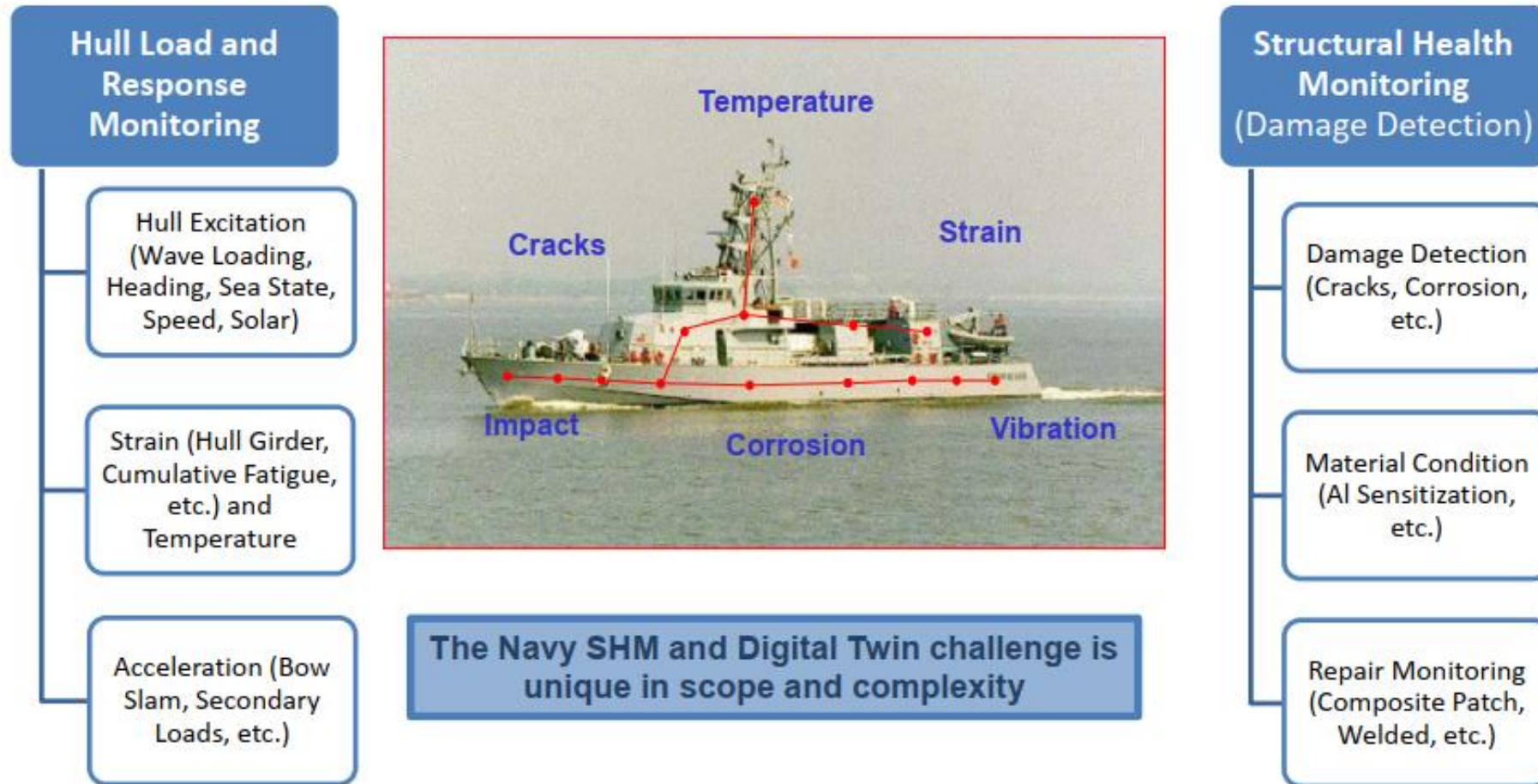

Aim: Collect sufficient data to inform a digital twin and enable improved Condition Based Maintenance.

Prior Work: Real-time Model Updating

Real-Time Model Updating Through Error Minimization

A frequency-based model updating technique was developed to update an FEA model of the system.

Experimental

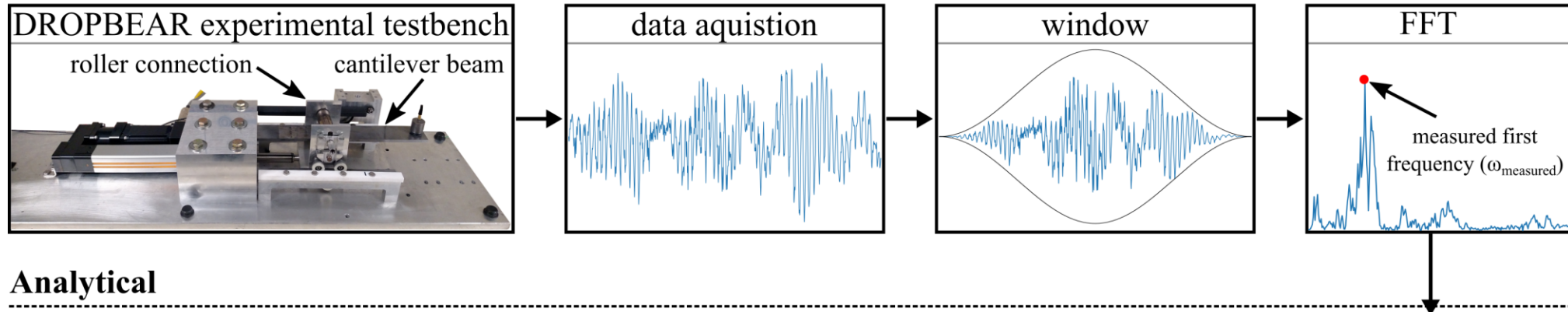

Analytical

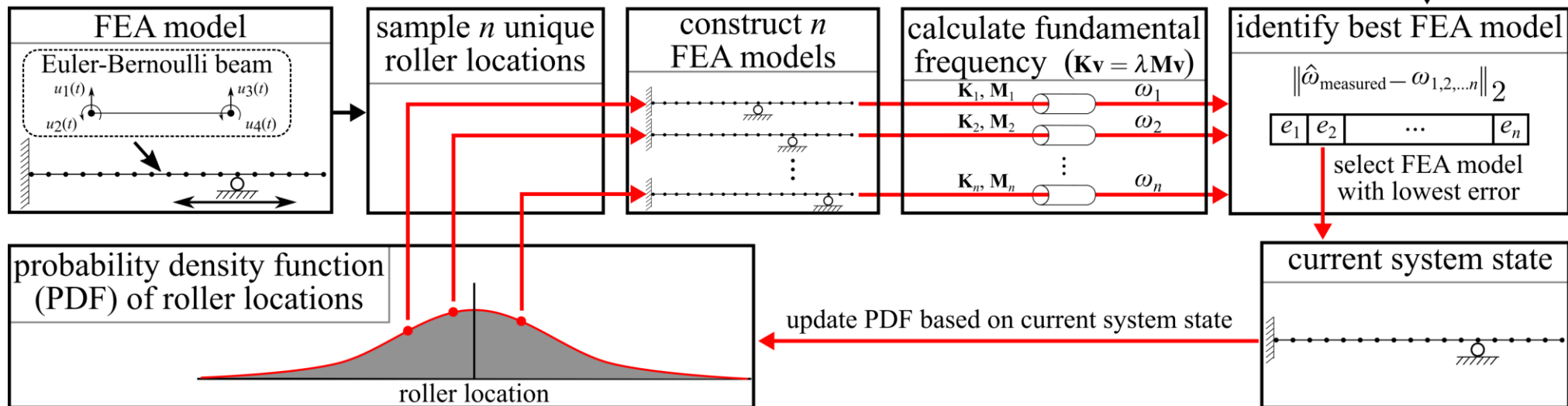

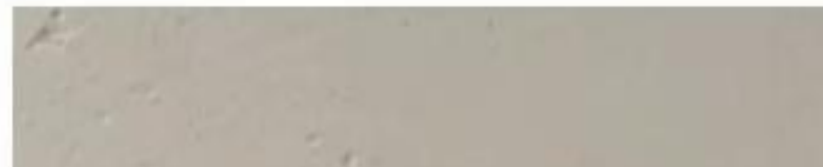
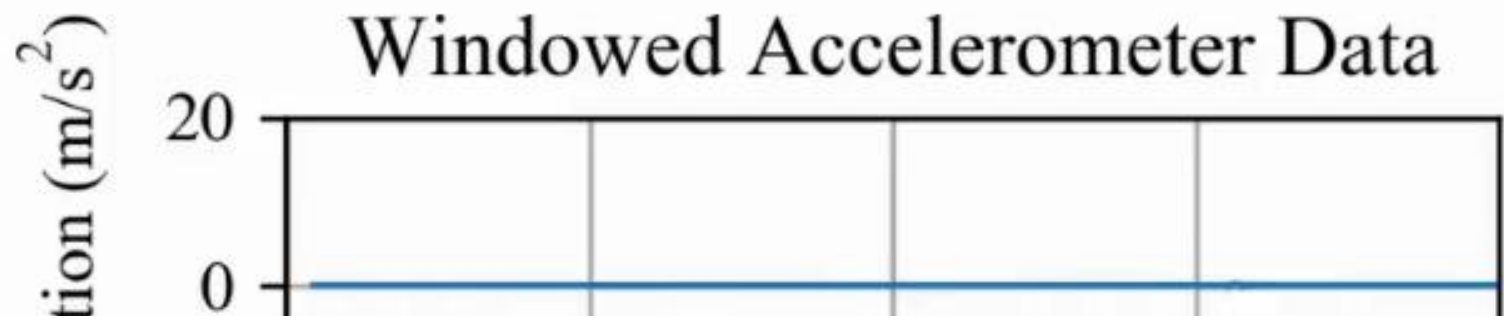
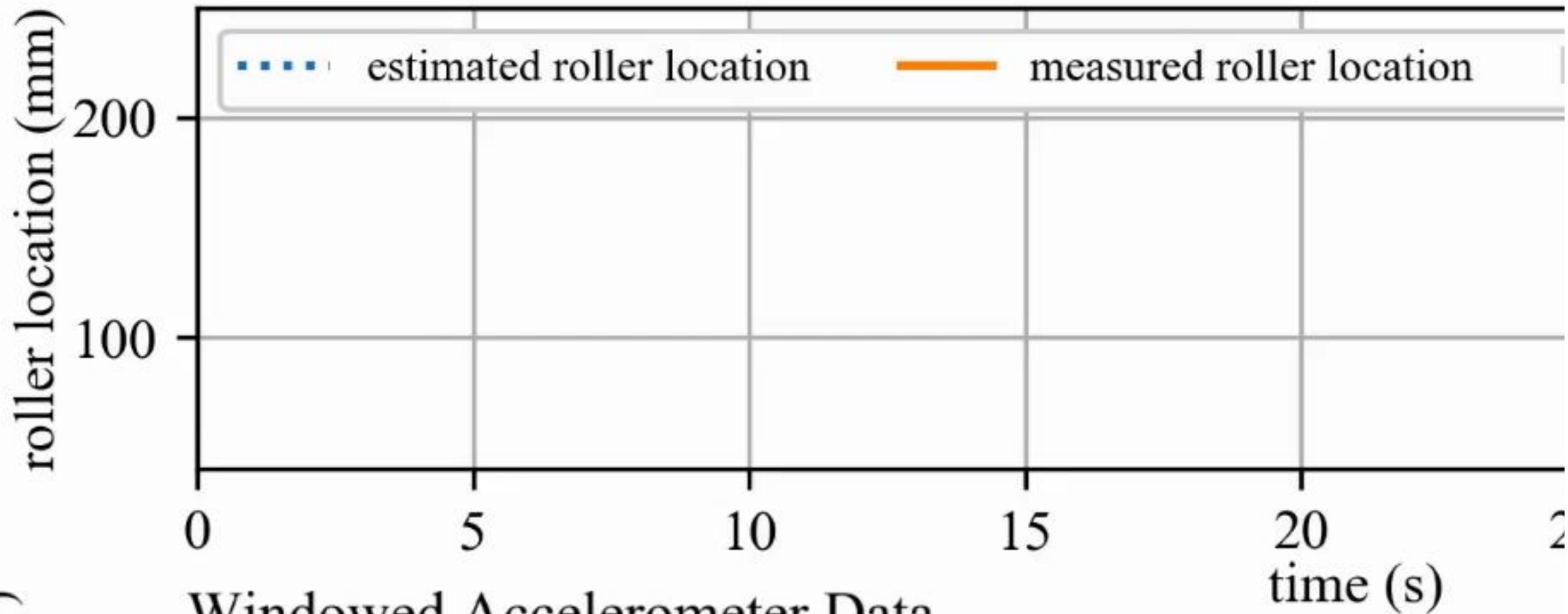

Experimental Results: Model Updating

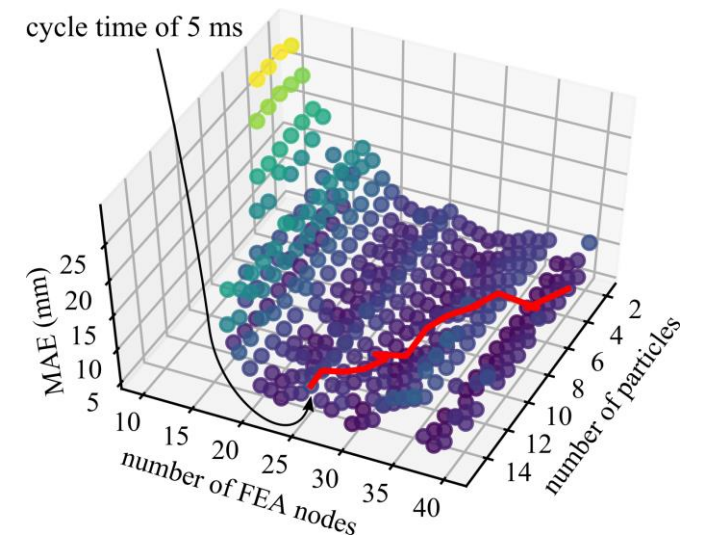
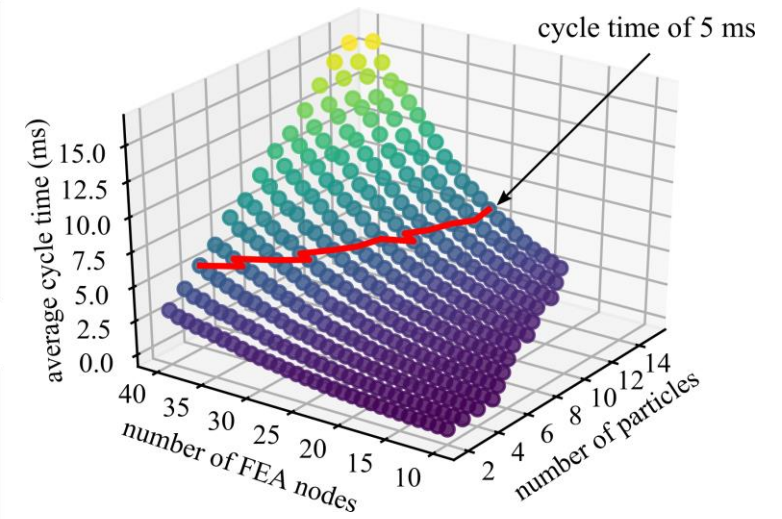
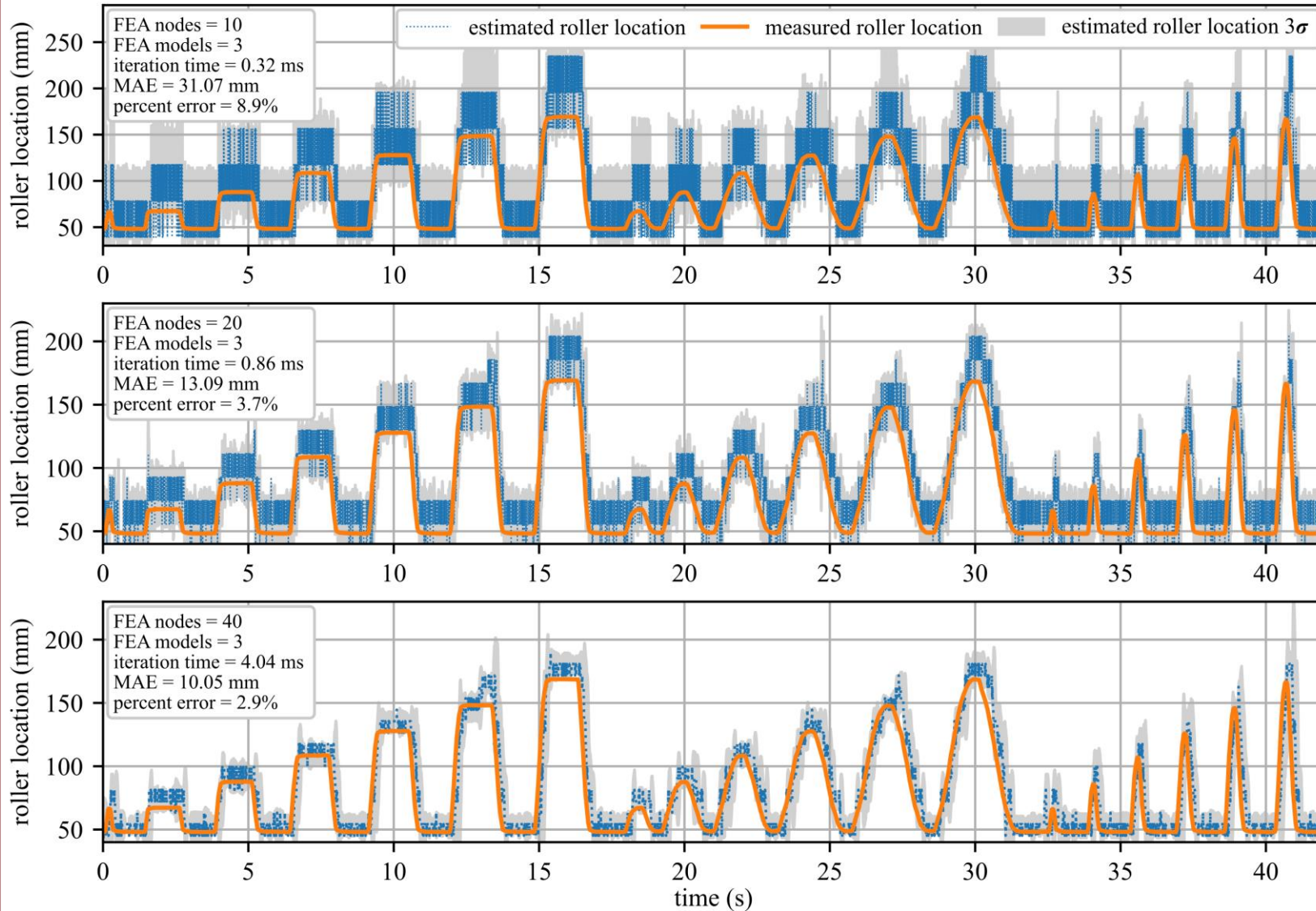

Experimental Results: Algorithm Timing

- Code run in parallel on multi-core processors using floating point precision variables.
- The FFT causes a delay in the estimation of the system.
- The length of the FFT is a function of the dynamics in the system.

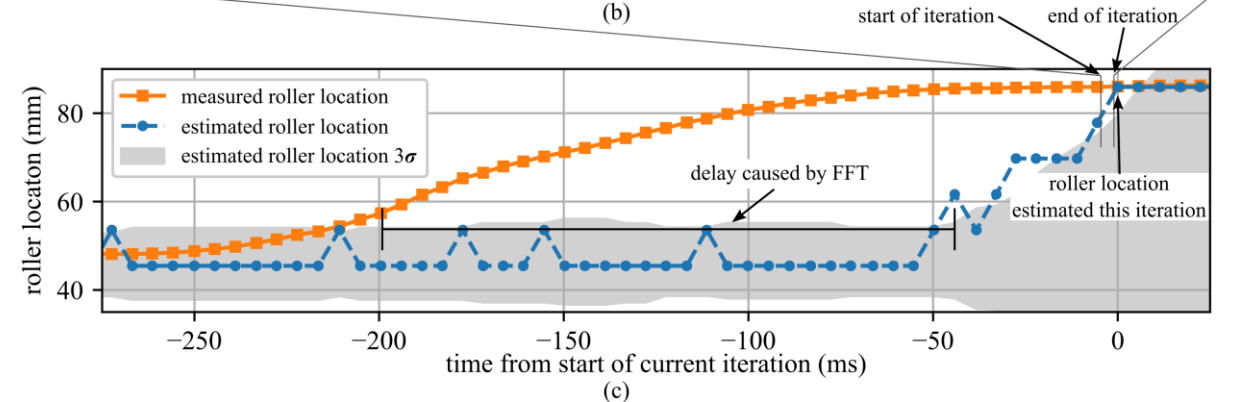
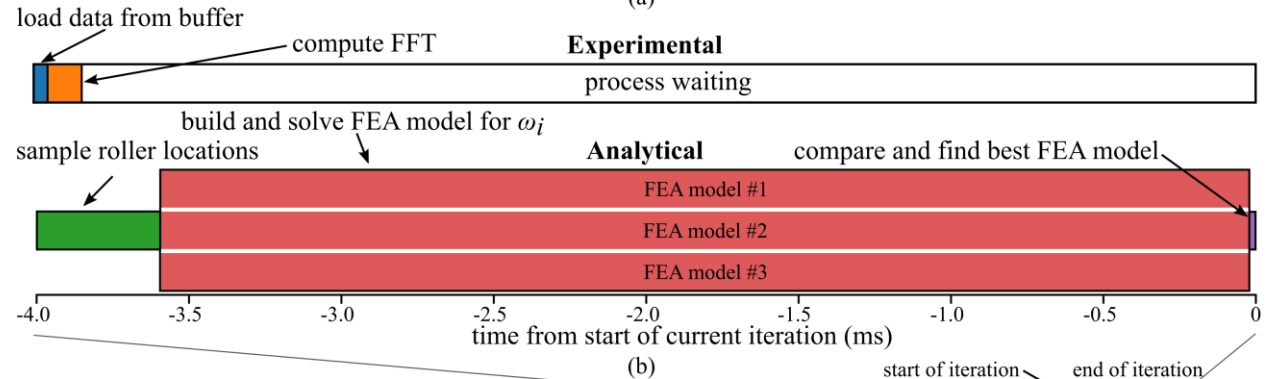
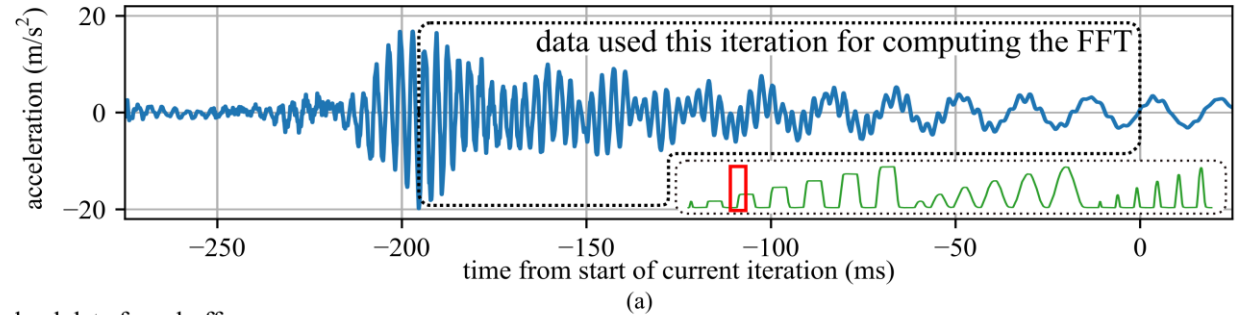
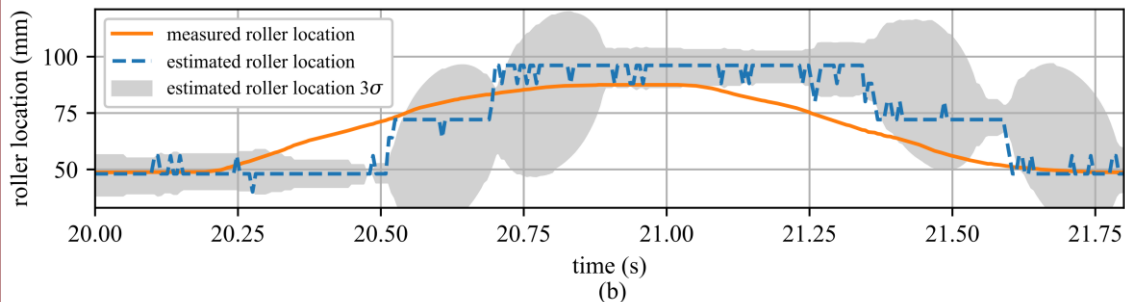
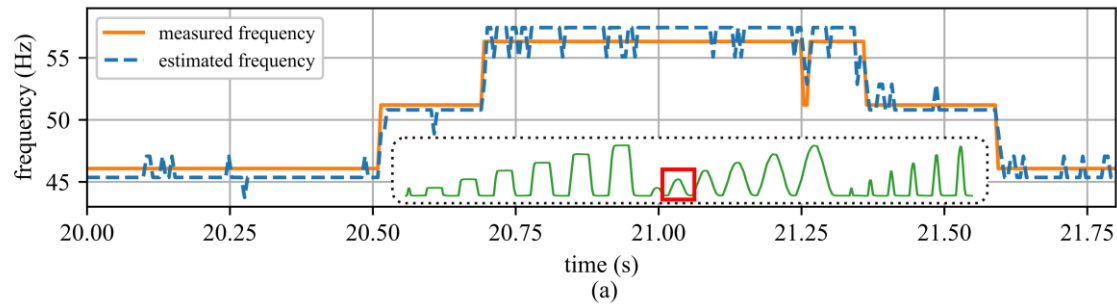

Experimental Results: Impact and Stochastic Testing

Impact Testing

- The frequency-based model updating algorithms can track the system state through an impact.
- This has benefits for system tracking of fuzzes in hard target penetrating systems.

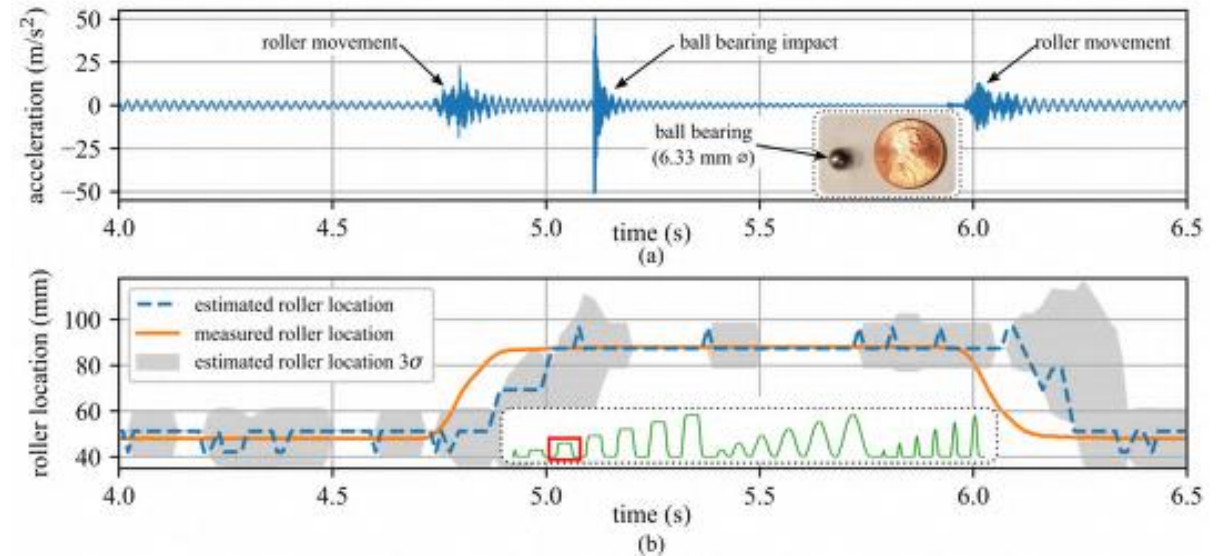
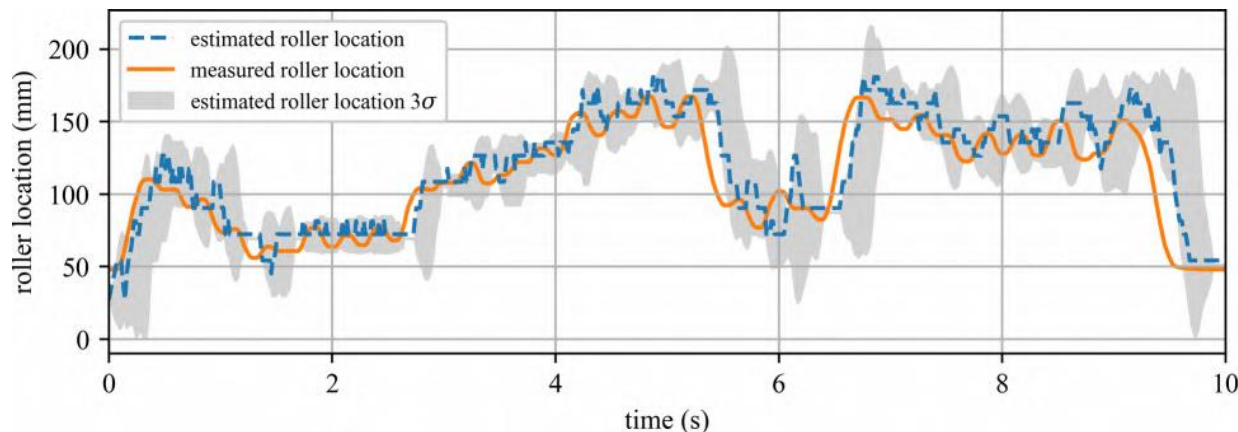

Stochastic Testing

- A random data set was used to investigate the algorithm's tracking capability.
- The algorithm is shown to accurately track the system state.

Multi-model Data Assimilation

Question: Can we develop a method to update fatigue and impact in a single model?

Research plan:

- Thrust 1: Develop a 1-D test structure.
- Thrust 2: Develop tools for multi-modal data assimilation.

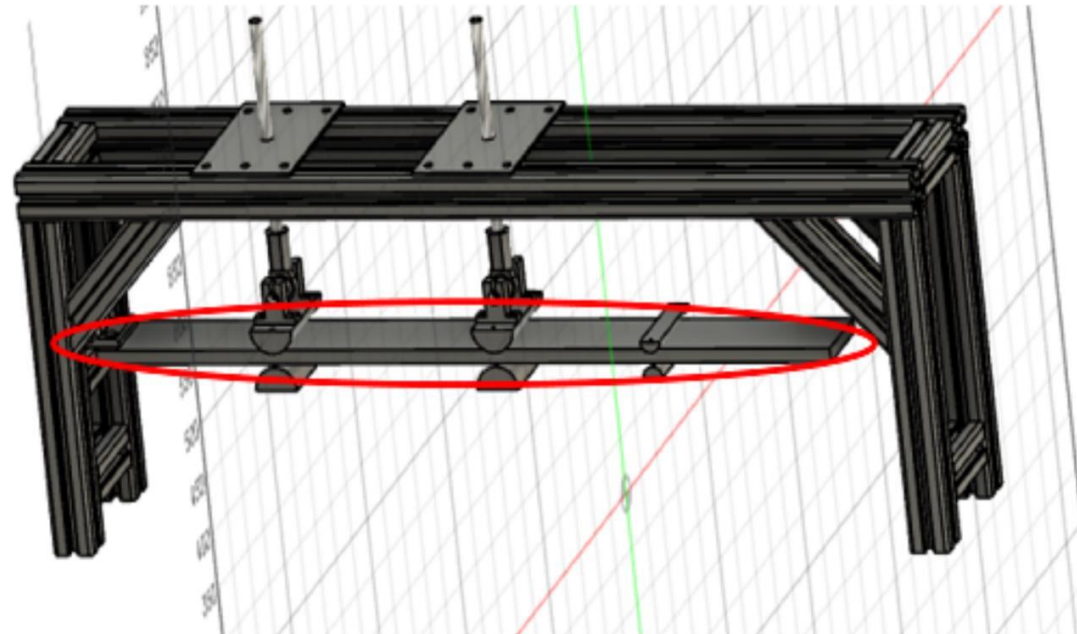
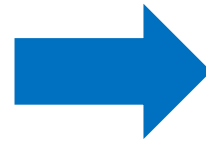

Thrust 1: Develop a 1-D test structure.

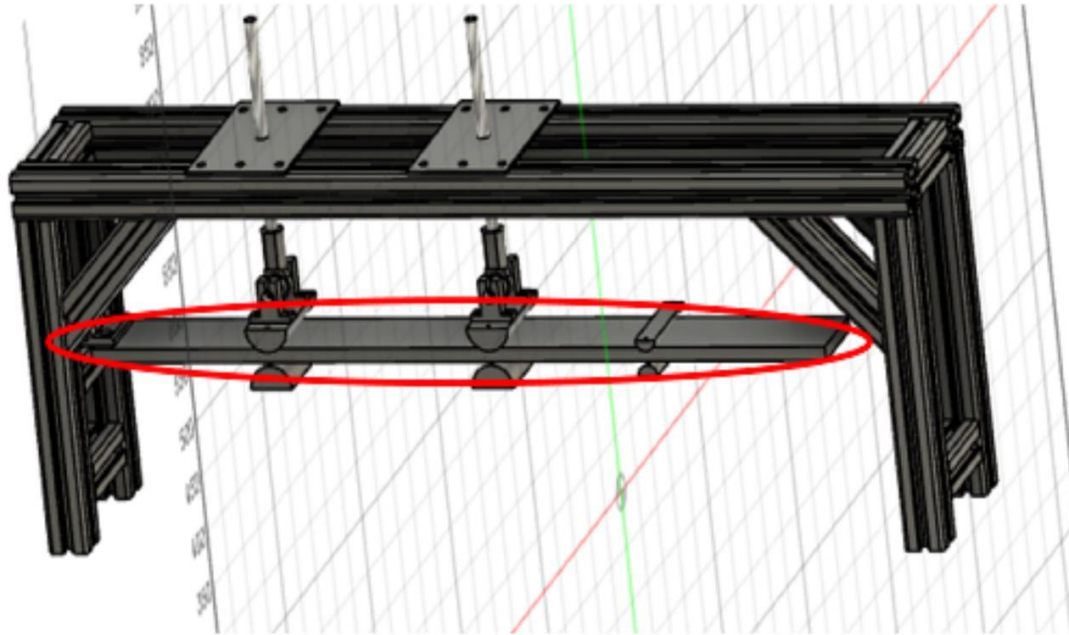

- System being designed/developed to simulate a component in a ship hull.
- System will be used to generate Distribution-A data for future publications.

- Similar system developed with the AFRL for real-time model updating of structures experiencing high-rate dynamics.

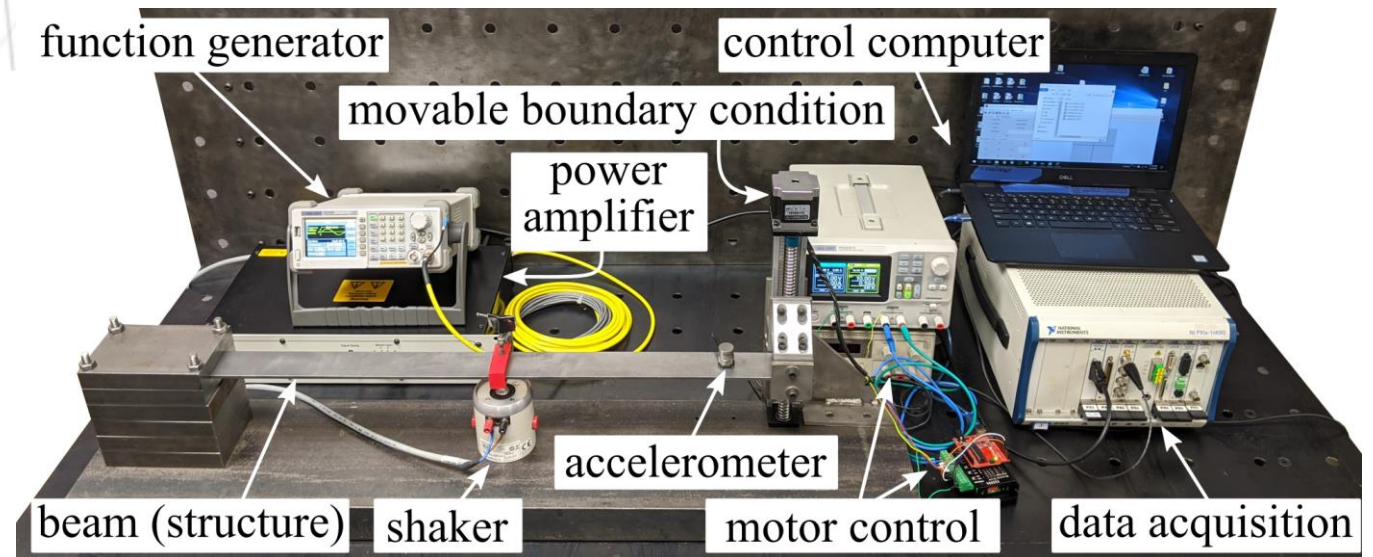

Thrust 2: Develop tools for multi-modal data assimilation.

- Develop an FEA-based model updating framework that can consider both cracks (e.g., fatigue) and impacts.

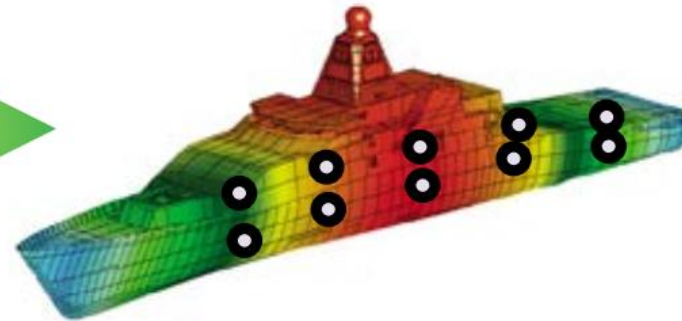

FEA Modeling

- Due to lab closures at Carderock and the UofSC, the experimental setup was built as an FEA model.
- Roller movement simulates damage caused by impact.

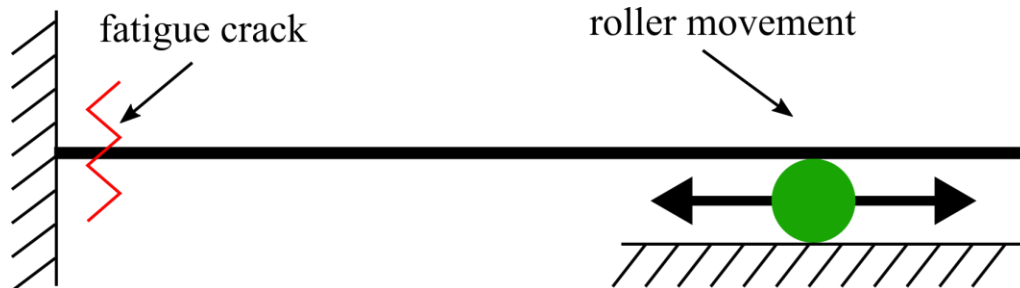

Shell element model of the cantilever beam

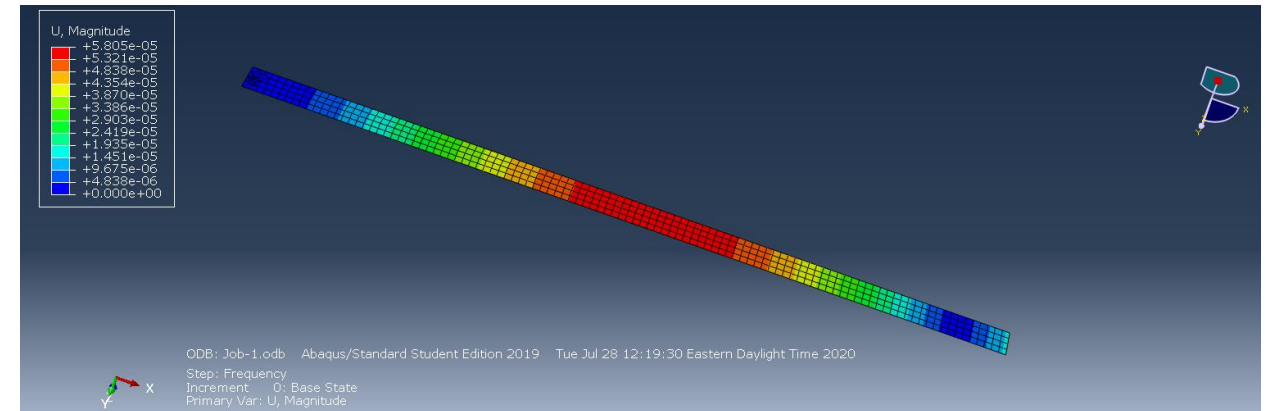

Fatigue crack modeled as a hole in the cantilever beam

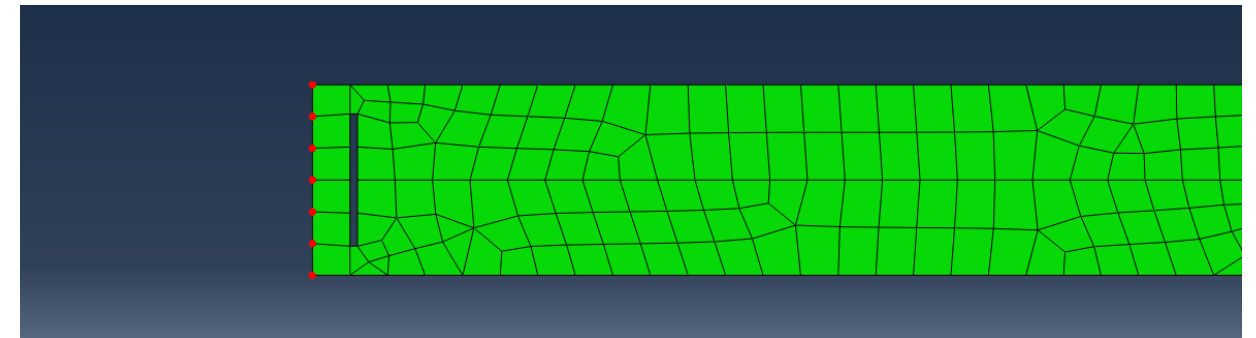

Background: Modal Analysis

Modal analysis is used to find the mode shapes and frequencies of a structure during free vibration.

Starting with the equation of motion:

$$\mathbf{M}\ddot{x} + \mathbf{C}\dot{x} + \mathbf{K}x = 0$$

the damping coefficient can be ignored as its effect on the natural frequency is less than 0.0005%, resulting in the expression:

$$\mathbf{M}\ddot{x} + \mathbf{K}x = 0$$

assuming a temporal solution:

$$x(t) = \Phi(A_n \cos(\omega_n t) + B_n \sin(\omega_n t))$$

yields the following expression:

$$\left(-\Omega_n^2 \mathbf{M}\Phi + \mathbf{K}\Phi_n \right) q_n(t) = 0$$

where $q_n(t)=0$ is a trivial solution, therefore the eigenvalues and eigenvectors are solved for using the general eigenvalue problem formulation:

$$\mathbf{K}\Phi_n = \lambda_n \mathbf{M}\Phi_n$$

where:

$$\lambda_n = \Omega_n^2$$

and:

$$\omega_n = \sqrt{\lambda_n}$$

The challenge with updating a model for multiple parameters is uniqueness.

Change in frequencies of the system

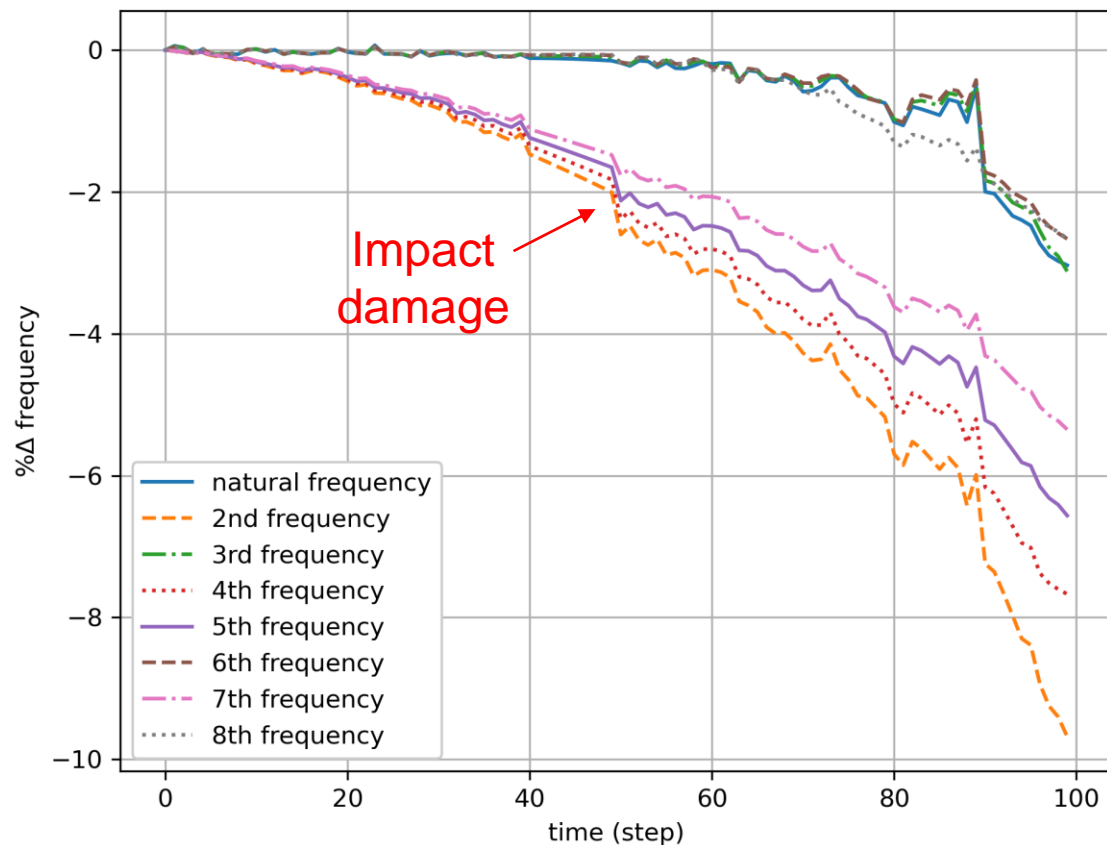

- For a given measurable frequency, the structure could be in a number of damage states.

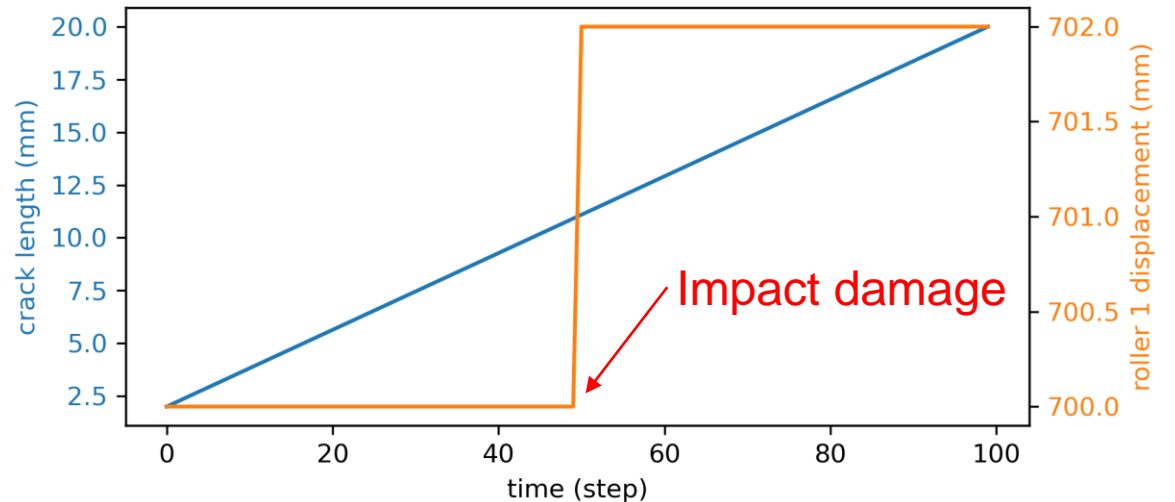

Investigating a Variety of parameters can potentially help

“Z” direction mode shapes for beam

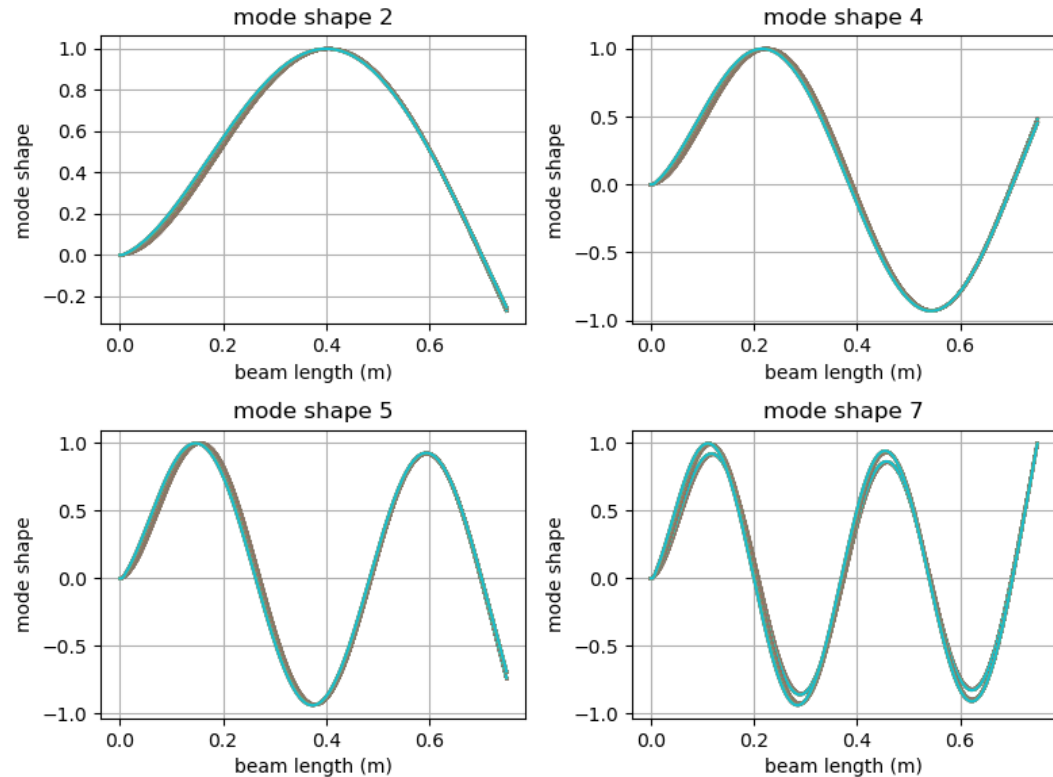

Change in participation factors

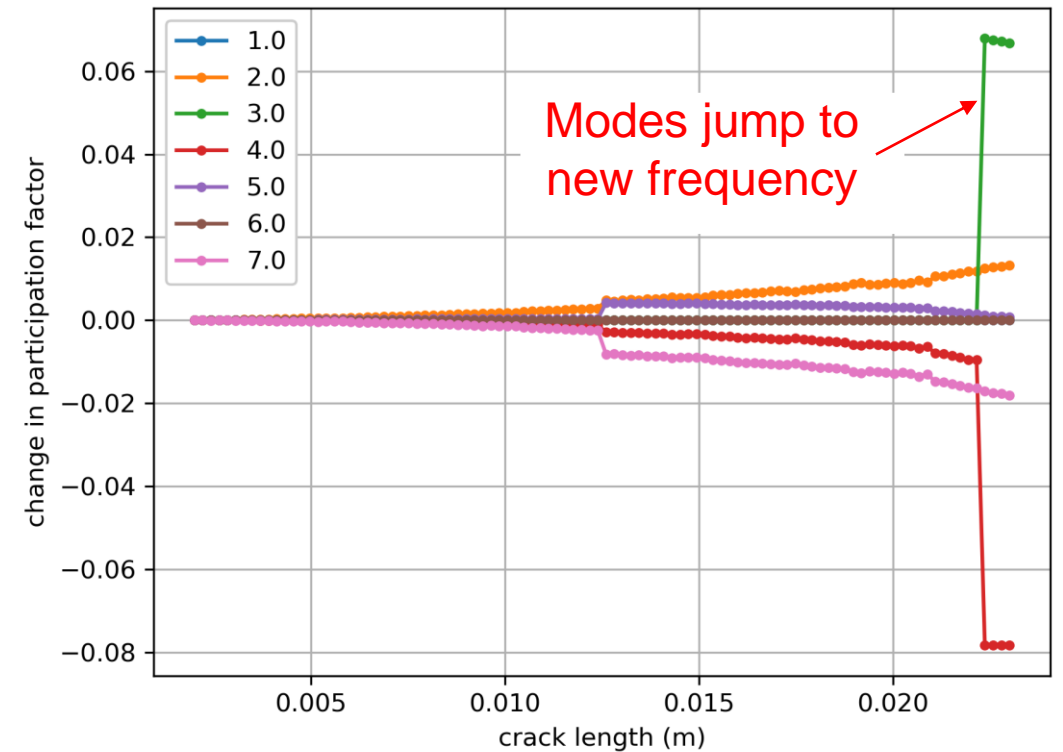

Modes change with a change in the K or M matrix (i.e. fatigue or roller movement).

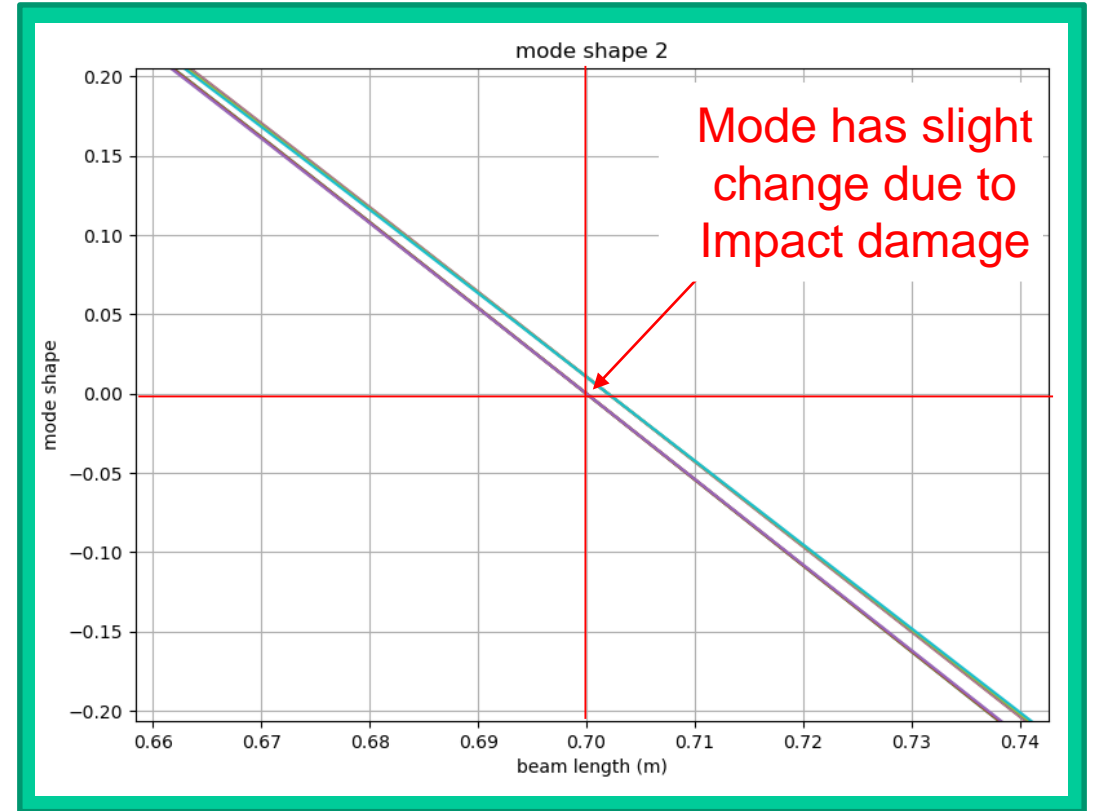
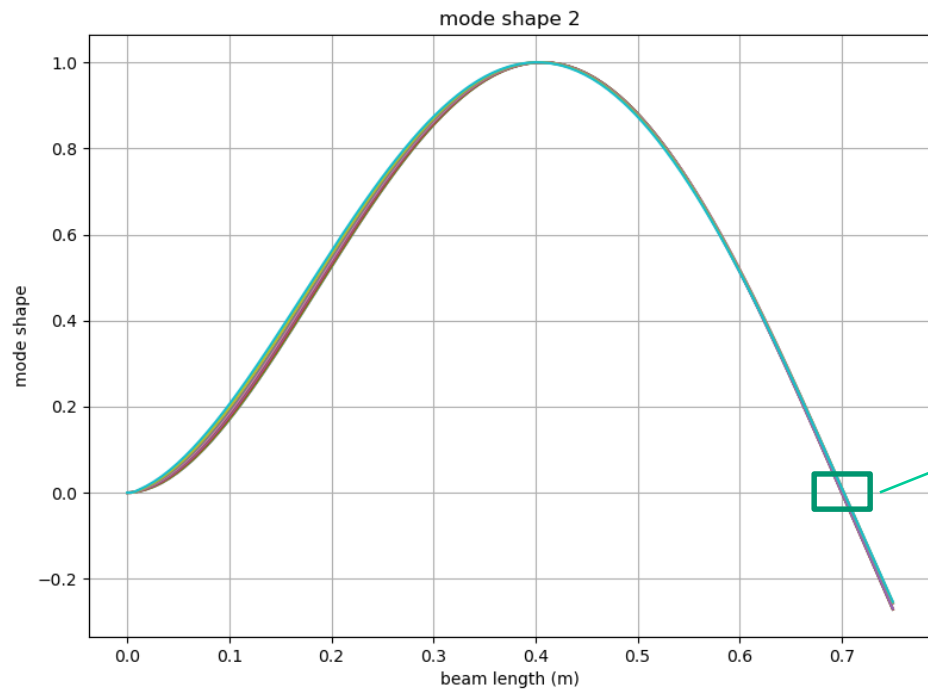

Modes change with a change in the K or M matrix (i.e. fatigue or roller movement).

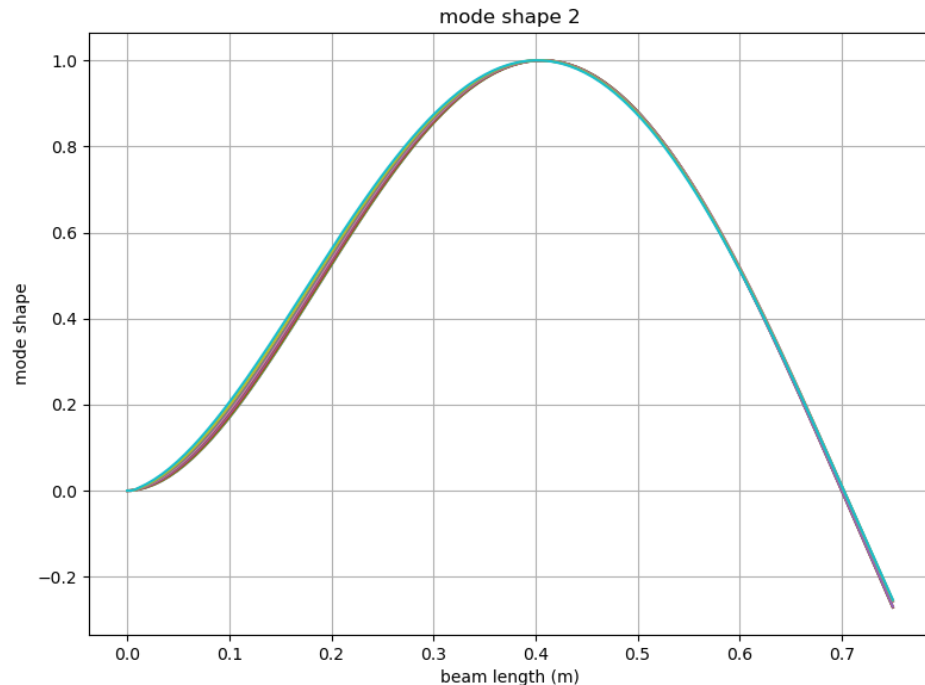

Modes change with a change in the K or M matrix (i.e. fatigue or roller movement).

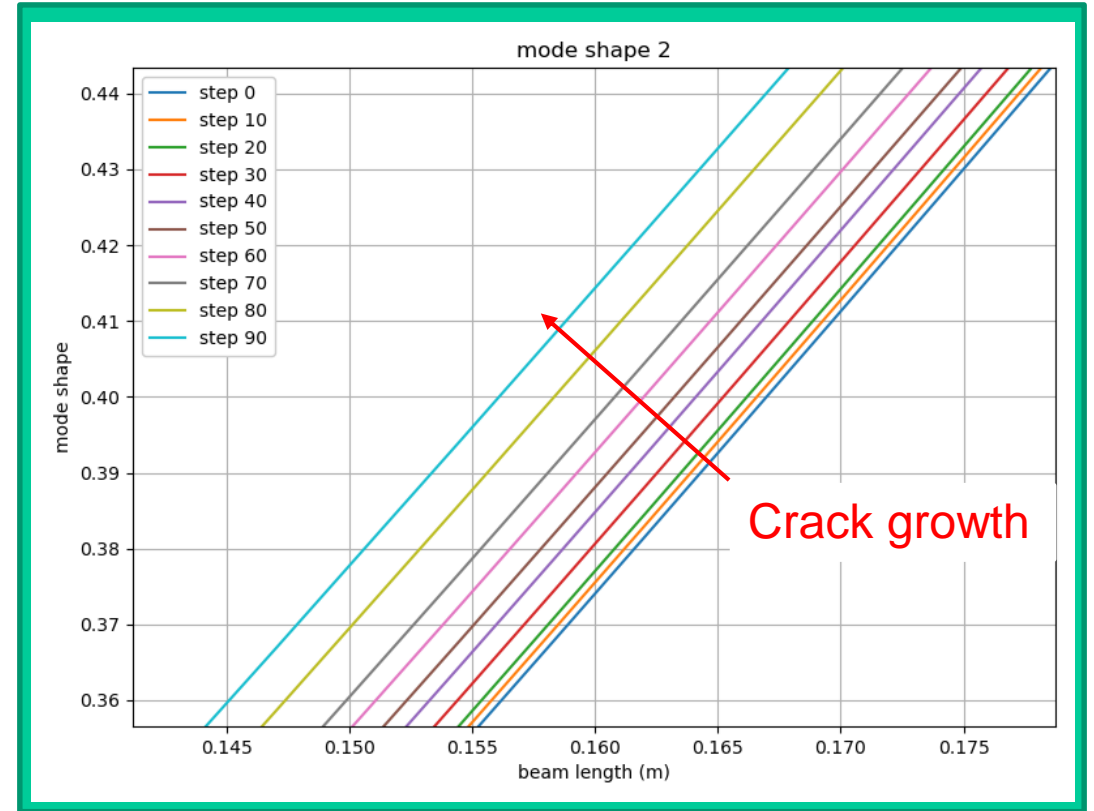
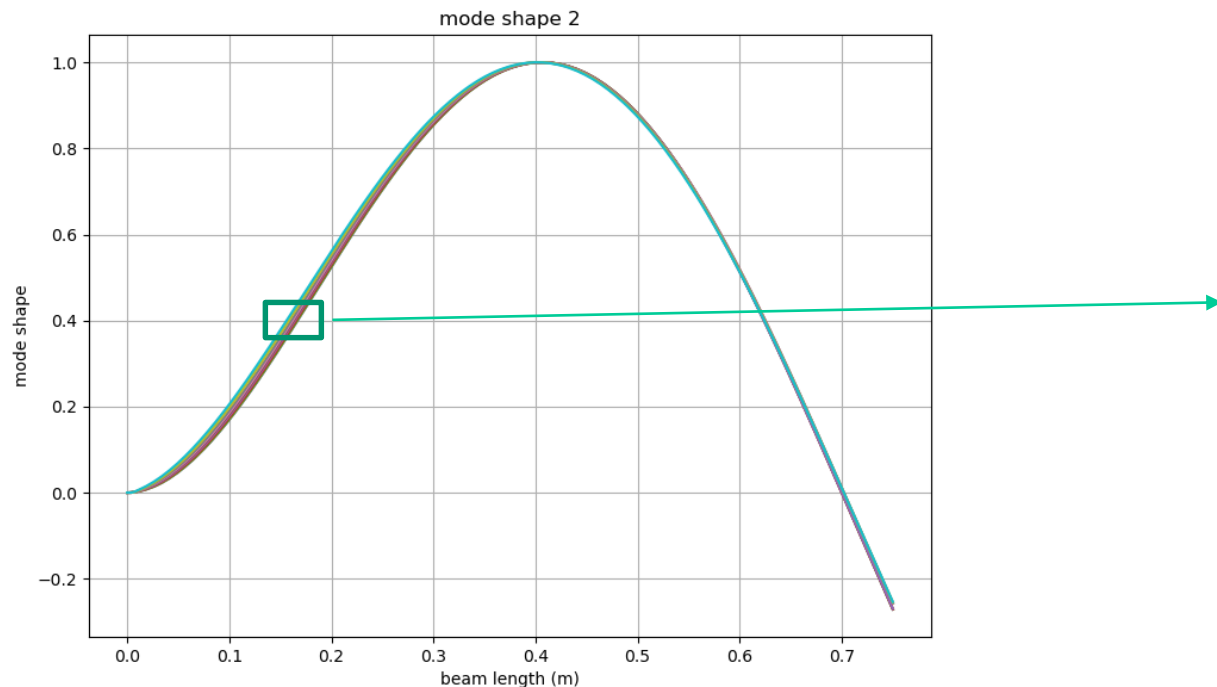

Gradient decent-based model updating approach

- Gradient descent is a simple method for optimization (first-order iterative).
- Provides a simple space to inspect results.
- Provides a simple approach that is mathematically (hopefully) tractable.
- Several options for potential options if we can show the response surface in concave:
 - Particle Swarm
 - Stochastic gradient decent
 - Batch gradient decent

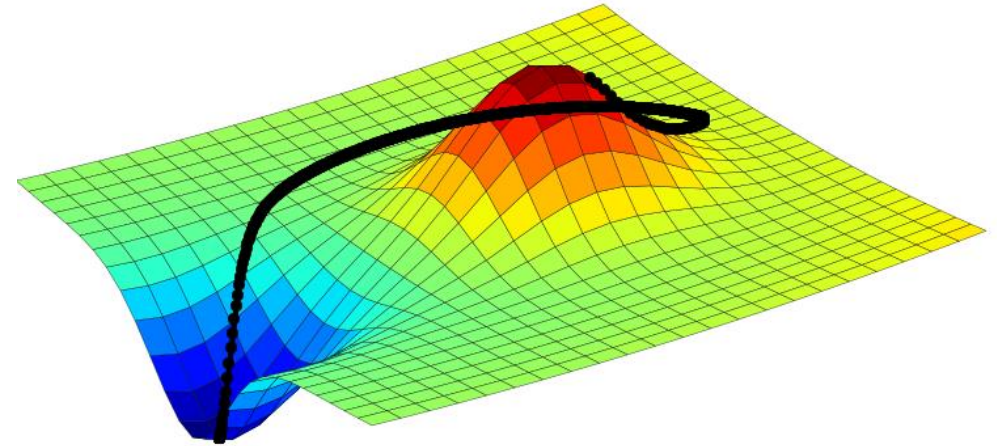

<https://medium.com/@DBCerigo/on-why-gradient-descent-is-even-needed-25160197a635>

Determine an effective cost function

Initial testing investigated the **direct model-based approach (DMBA)**:

$$J_{\text{DMBA}} = \sum_{i=1}^n \left(\frac{\omega_i^{\text{true}} - \omega_i^{\text{trial}}}{\omega_i^{\text{trial}}} \right)^2 + \alpha \sum_{i=1}^n \frac{(1 - \sqrt{\text{MAC}_i})^2}{\text{MAC}_i}$$

where:

$$\text{MAC}_i = \frac{|(\phi_i^{\text{true}})^T(\phi_i^{\text{trial}})|^2}{\{(\phi_i^{\text{true}})^T(\phi_i^{\text{true}})\}\{(\phi_i^{\text{trial}})^T(\phi_i^{\text{trial}})\}}$$

The objective function considers n modes with ω_i^{true} and ω_i^{trial} being the modal frequencies of a true structure and a trial model, respectively, for the i^{th} mode. The weighting term, α , allows the objective function to weight the mode shape differences relative to the modal frequencies.

Building on prior work performed in collaboration with NSWC-Carderock

Model-based fatigue crack detection (1/8" cut) in aluminum plate with stiffener.

Results for probability of damage location.

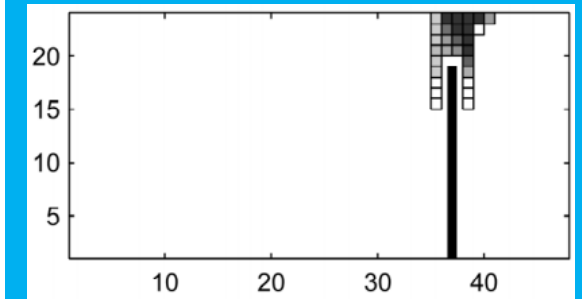
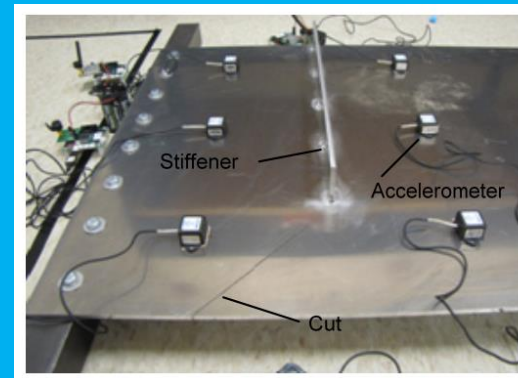

Kurata, Masahiro, Jun-Hee Kim, Jerome P. Lynch, Kincho H. Law, and Liming W. Salvino. "A probabilistic model updating algorithm for fatigue damage detection in aluminum hull structures." In *Smart Materials, Adaptive Structures and Intelligent Systems*, vol. 44168, pp. 741-750. 2010.

Determine an effective cost function

Furthermore, the **Flexibility-based Approach (FBA)** was also investigated. The FBA method provides an objective function by computing the differences between the truncated flexibility matrices for the true and trial models. This method is less sensitive to higher modes.

The stiffness matrix K and the flexibility F matrix linked through the mode shapes Φ as follows:

$$K = M\bar{\Phi}\Omega\bar{\Phi}^T M$$

and

$$F = \bar{\Phi}\Omega^{-1}\bar{\Phi}^T = \sum_{i=1}^n \frac{1}{\omega_i^2} \bar{\phi}_i \bar{\phi}_i^T$$

where the bar denotes a mass-normalized quantity. The normalized mode shape ($\bar{\phi}_i$) is coupled to the mass-normalized mode via a mass normalization constant d_i :

$$\bar{\phi}_i = \phi_i d_i$$

For a select number (n) of the lower mode shapes, a truncated flexibility matrix is defined as:

$$F_{turn} = \sum_{i=1}^n \left(\frac{d_i}{\omega_i} \right)^2 \bar{\phi}_i \bar{\phi}_i^T$$

Thereafter, a flexibility matrix is constructed for the *true* and *trial* FEA case, the difference is defined as:

$$\Delta F_{turn} = F_{turn}^{true} - F_{turn}^{trial}$$

Where ΔF_{turn} is a matrix. Lastly, a scalar value for ΔF_{turn} can be obtained by computing the Frobenius norm of ΔF_{turn} , defined as:

$$\|\Delta F_{turn}\|_F = \sqrt{\sum_{i=1} \sum_{j=1} x_{ij}^2}$$

Response space for DMBA

- Model tested for a test condition with a 10 mm crack and a roller at 700 mm.
- Modes 2, 4, 5, and 7 are modes that participate in the Z-axis.
- We consider a growing number of modes:
 - Mode 2
 - Modes 2 and 4
 - Modes 2, 4, and 5
 - Modes 2, 4, 5, and 7
- The use of 4 modes gives the best response surface.

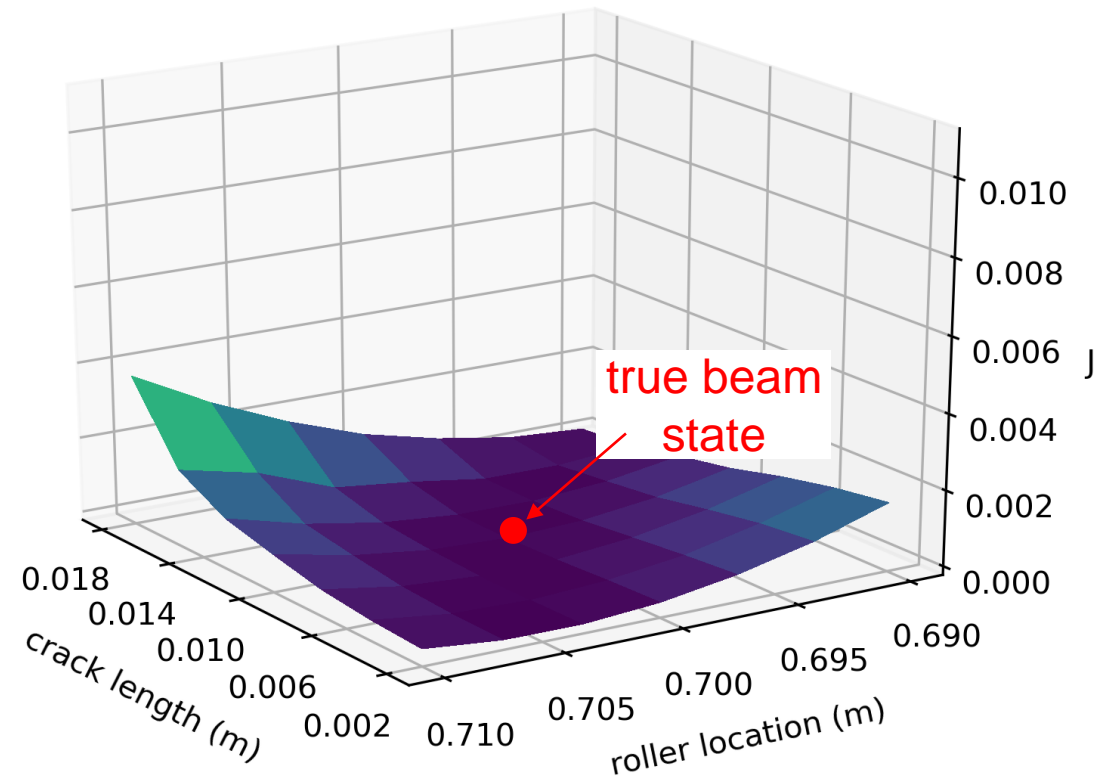

Response space for DMBA

- Model tested for a test condition with a 10 mm crack and a roller at 700 mm.
- Modes 2, 4, 5, and 7 are modes that participate in the Z-axis.
- We consider a growing number of modes:
 - Mode 2
 - Modes 2 and 4
 - Modes 2, 4, and 5
 - Modes 2, 4, 5, and 7
- The use of 4 modes gives the best response surface.

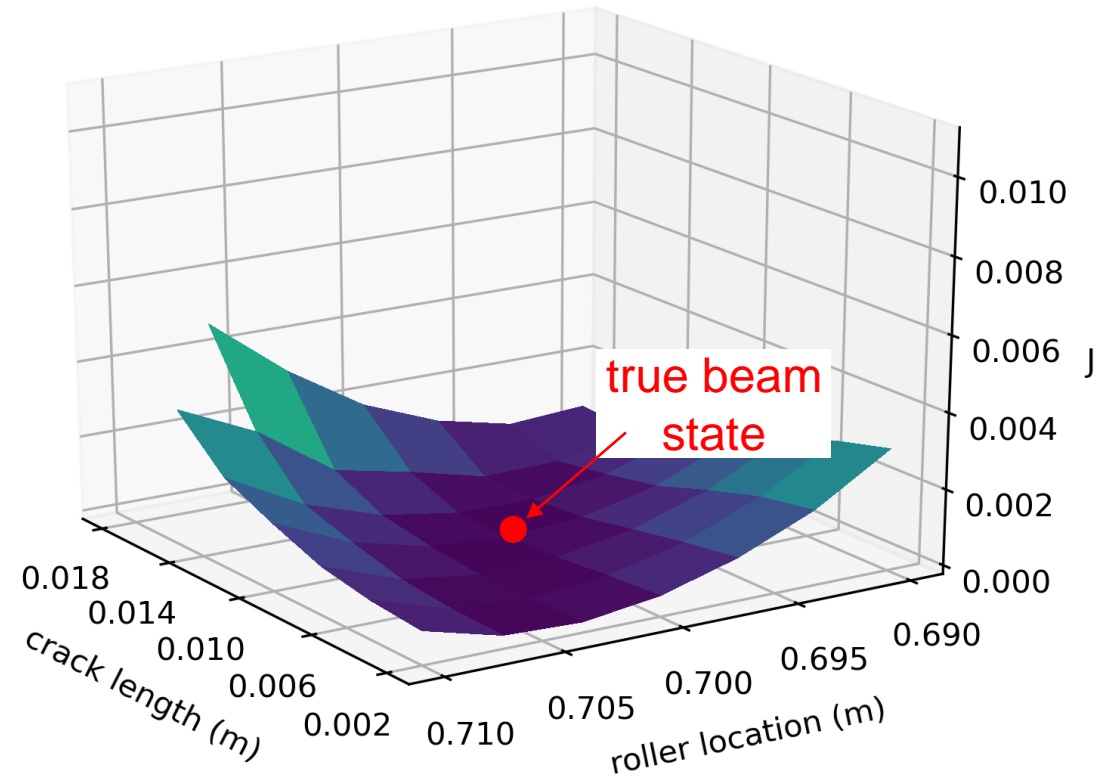

Response space for DMBA

- Model tested for a test condition with a 10 mm crack and a roller at 700 mm.
- Modes 2, 4, 5, and 7 are modes that participate in the Z-axis.
- We consider a growing number of modes:
 - Mode 2
 - Modes 2 and 4
 - Modes 2, 4, and 5
 - Modes 2, 4, 5, and 7
- The use of 4 modes gives the best response surface.

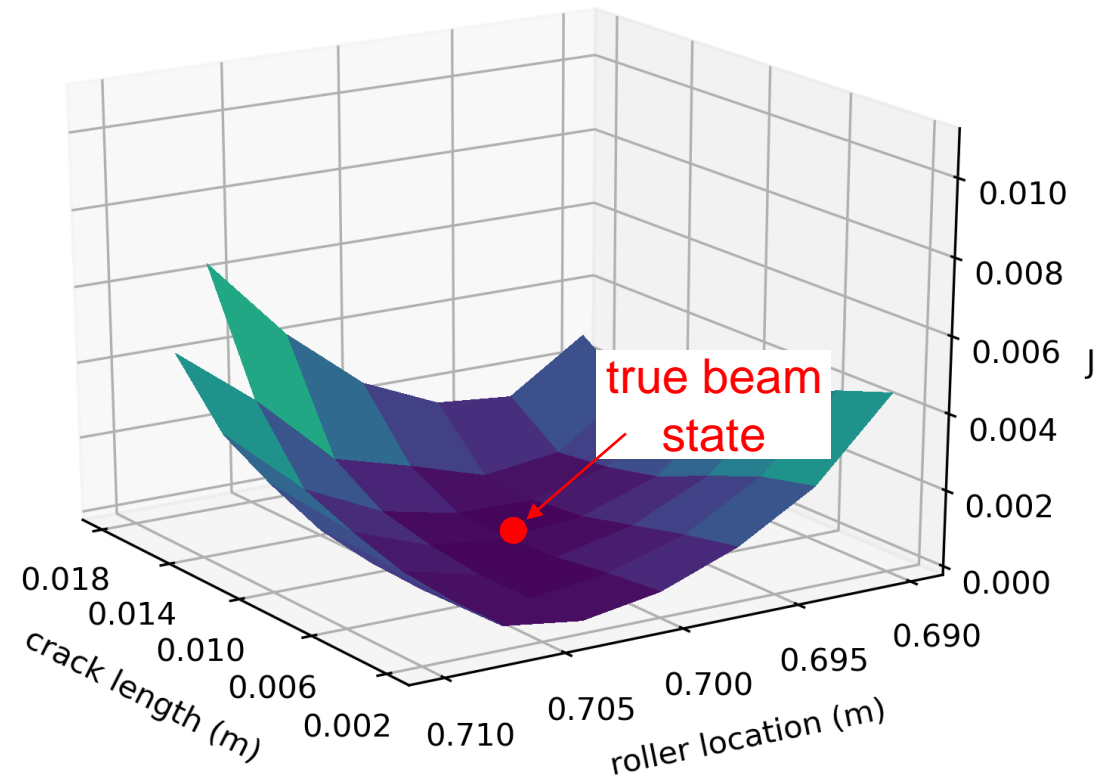

Response space for DMBA

- Model tested for a test condition with a 10 mm crack and a roller at 700 mm.
- Modes 2, 4, 5, and 7 are modes that participate in the Z-axis.
- We consider a growing number of modes:
 - Mode 2
 - Modes 2 and 4
 - Modes 2, 4, and 5
 - Modes 2, 4, 5, and 7
- The use of 4 modes gives the best response surface.

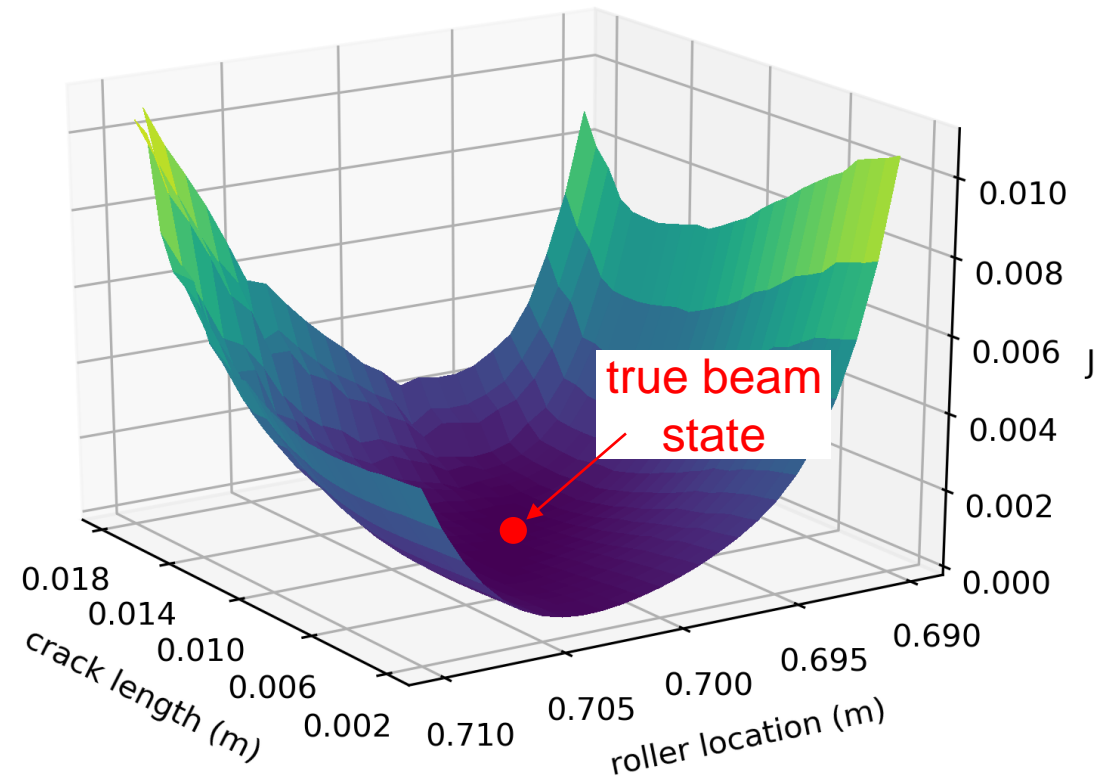

Response Space for Flexibility-based Approach

- Model tested for a test condition with a 10 mm crack and a roller at 700 mm.
- Modes 2, 4, 5, and 7 are modes that participate in the Z-axis.
- We consider a growing number of modes:
 - Mode 2
 - Modes 2 and 4
 - Modes 2, 4, and 5
 - Modes 2, 4, 5, and 7
- The use of 2 modes gives the same result as 4 modes due to the consideration of participation factors.

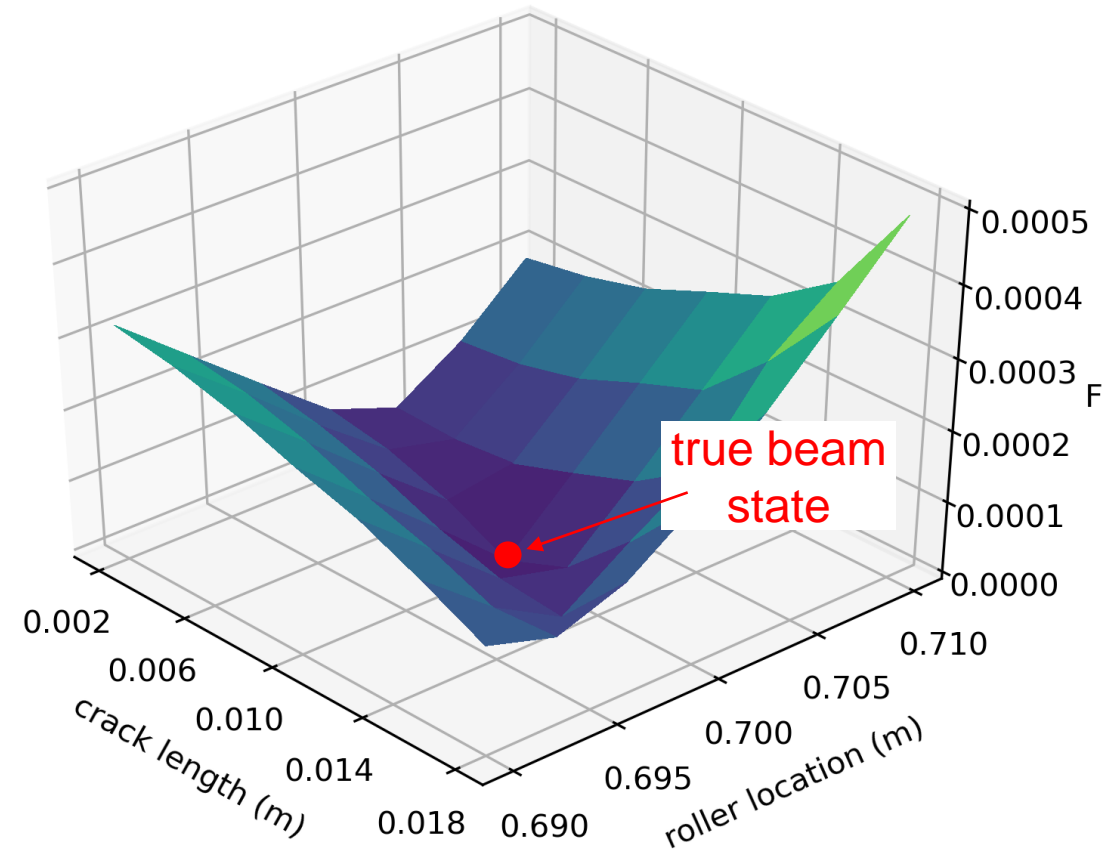

Response Space for Flexibility-based Approach

- Model tested for a test condition with a 10 mm crack and a roller at 700 mm.
- Modes 2, 4, 5, and 7 are modes that participate in the Z-axis.
- We consider a growing number of modes:
 - Mode 2
 - Modes 2 and 4
 - Modes 2, 4, and 5
 - Modes 2, 4, 5, and 7
- The use of 2 modes gives the same result as 4 modes due to the consideration of participation factors.

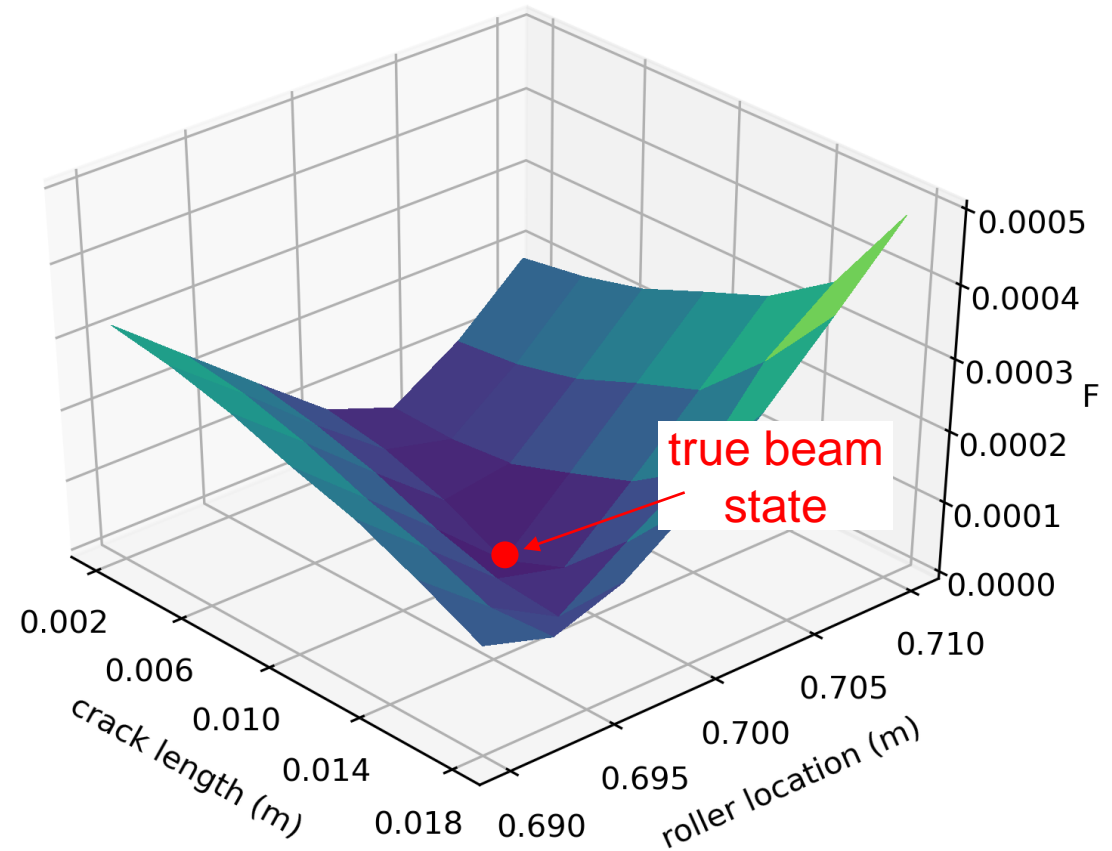

Response Space for Flexibility-based Approach

- Model tested for a test condition with a 10 mm crack and a roller at 700 mm.
- Modes 2, 4, 5, and 7 are modes that participate in the Z-axis.
- We consider a growing number of modes:
 - Mode 2
 - Modes 2 and 4
 - Modes 2, 4, and 5
 - Modes 2, 4, 5, and 7
- The use of 2 modes gives the same result as 4 modes due to the consideration of participation factors.

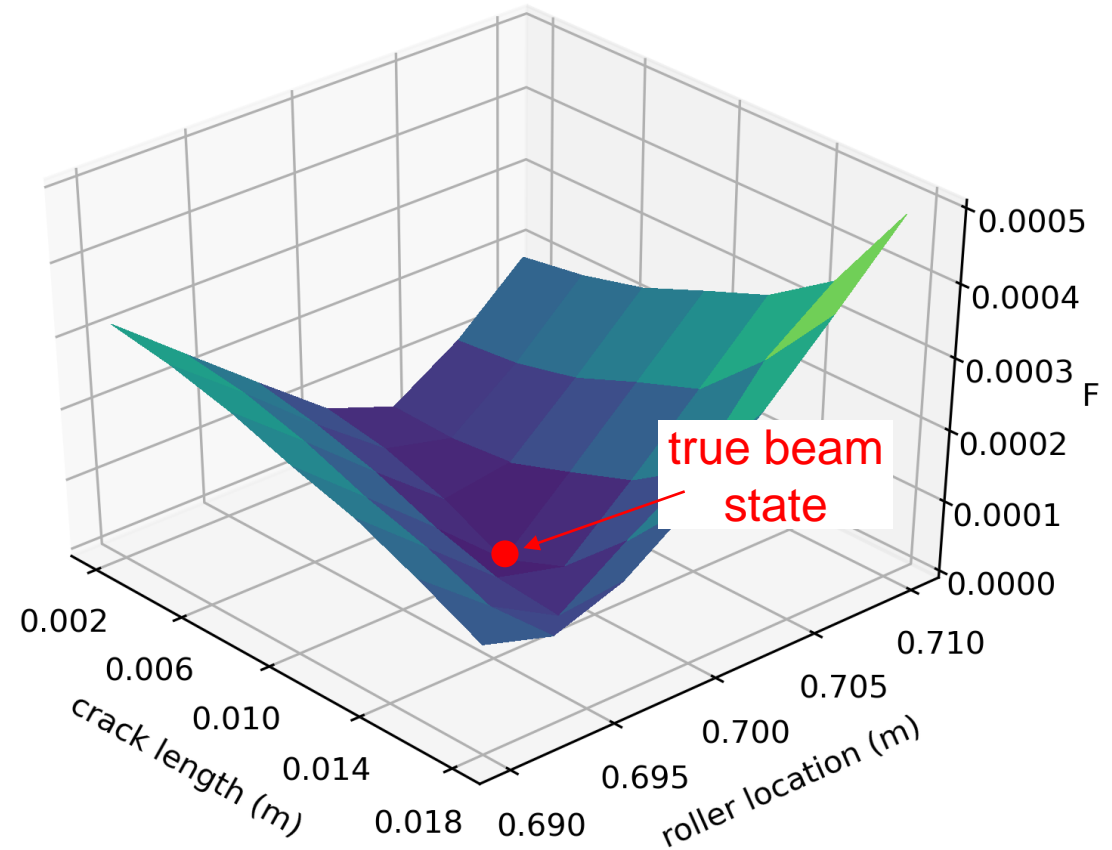

Response Space for Flexibility-based Approach

- Model tested for a test condition with a 10 mm crack and a roller at 700 mm.
- Modes 2, 4, 5, and 7 are modes that participate in the Z-axis.
- We consider a growing number of modes:
 - Mode 2
 - Modes 2 and 4
 - Modes 2, 4, and 5
 - Modes 2, 4, 5, and 7
- The use of 2 modes gives the same result as 4 modes due to the consideration of participation factors.

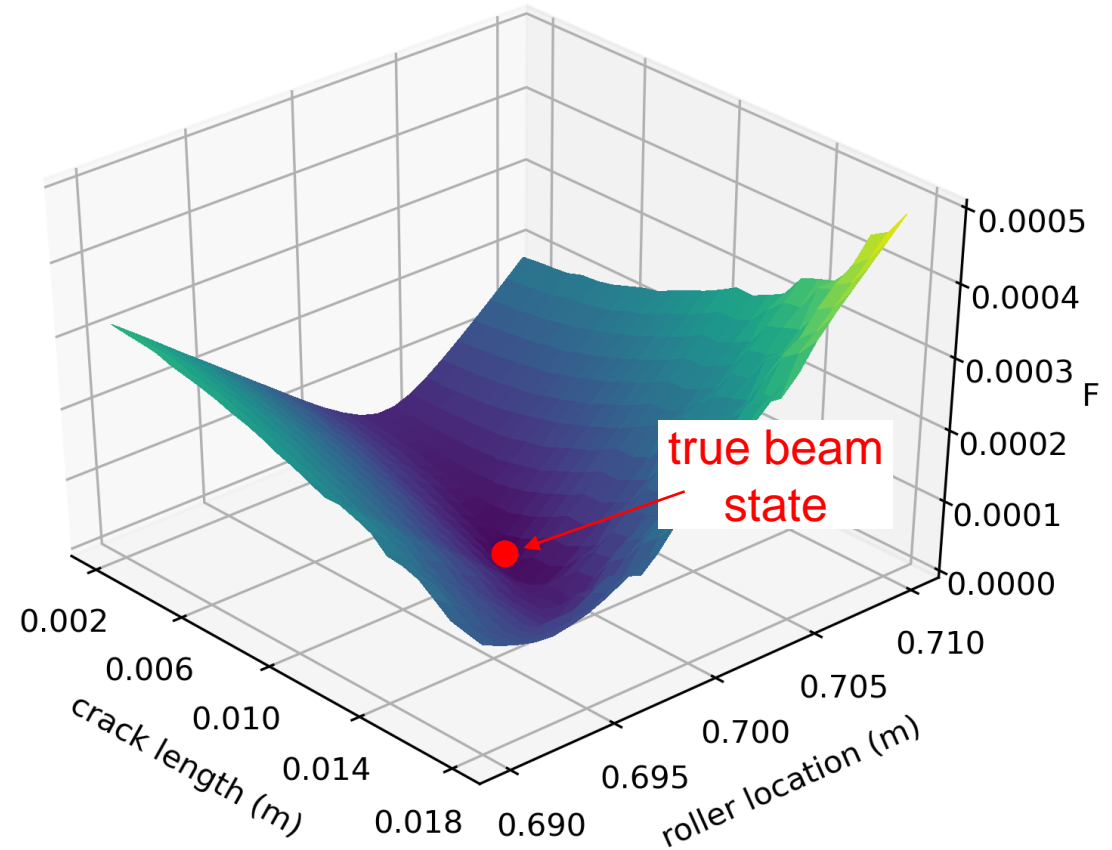

Discussion on results

- The direct mode-based approach (DMBA) is not on-its-own able to provide a local-min at the correct model parameters.
- With additional information, (i.e. deflection shape, crack length, roller location) the correct parameters could be obtained.
- The Flexibility-based Approach is shown to be a more efficient method for updating the model for various parameters.
- The Flexibility-based Approach requires knowledge of the mass normalization constants of the structure. These can be obtained either experimentally or numerically.
- The affects of noise in the system need to be studied.
- It can be challenging to extract the higher modes from experimental systems.

Mode 2

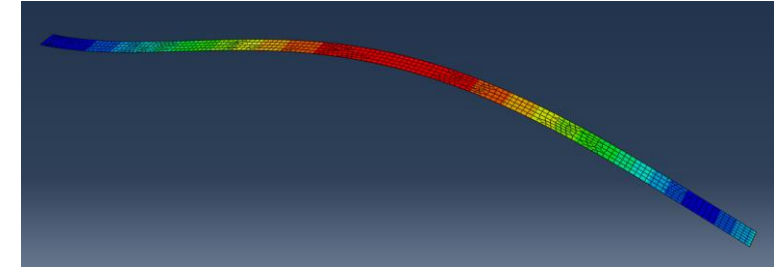

Mode 7

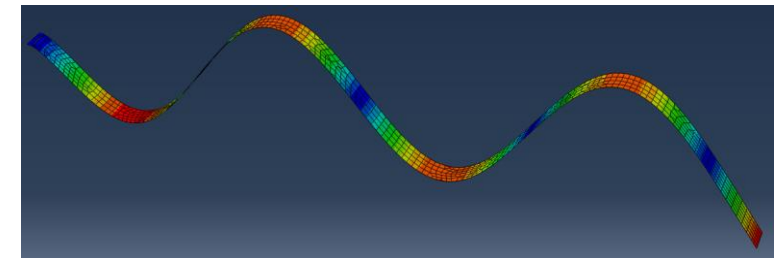

Key next steps in the research

- Investigate cost functions better suited for tracking multiple models.
- Integrate the participation factor into the cost function.
- Develop Bayesian-based method to obtain probabilities associated with each estimated parameter.
- Investigate the use of different gradient decent solvers.
- Develop experimental test-bench at the UofSC to experimentally validate this work.

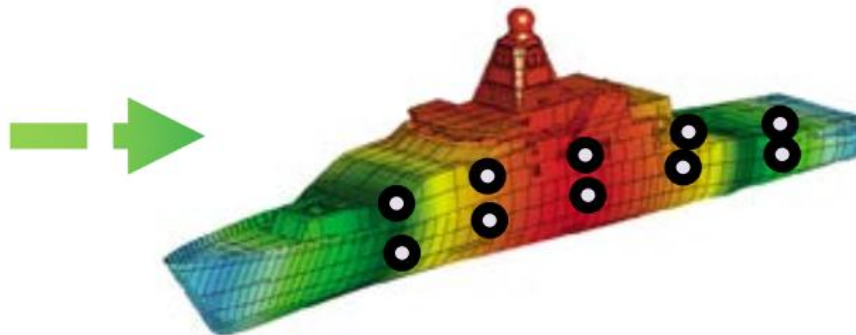

Long-term Vision for the Proposed Work

Dynamic Data Driven Applications System

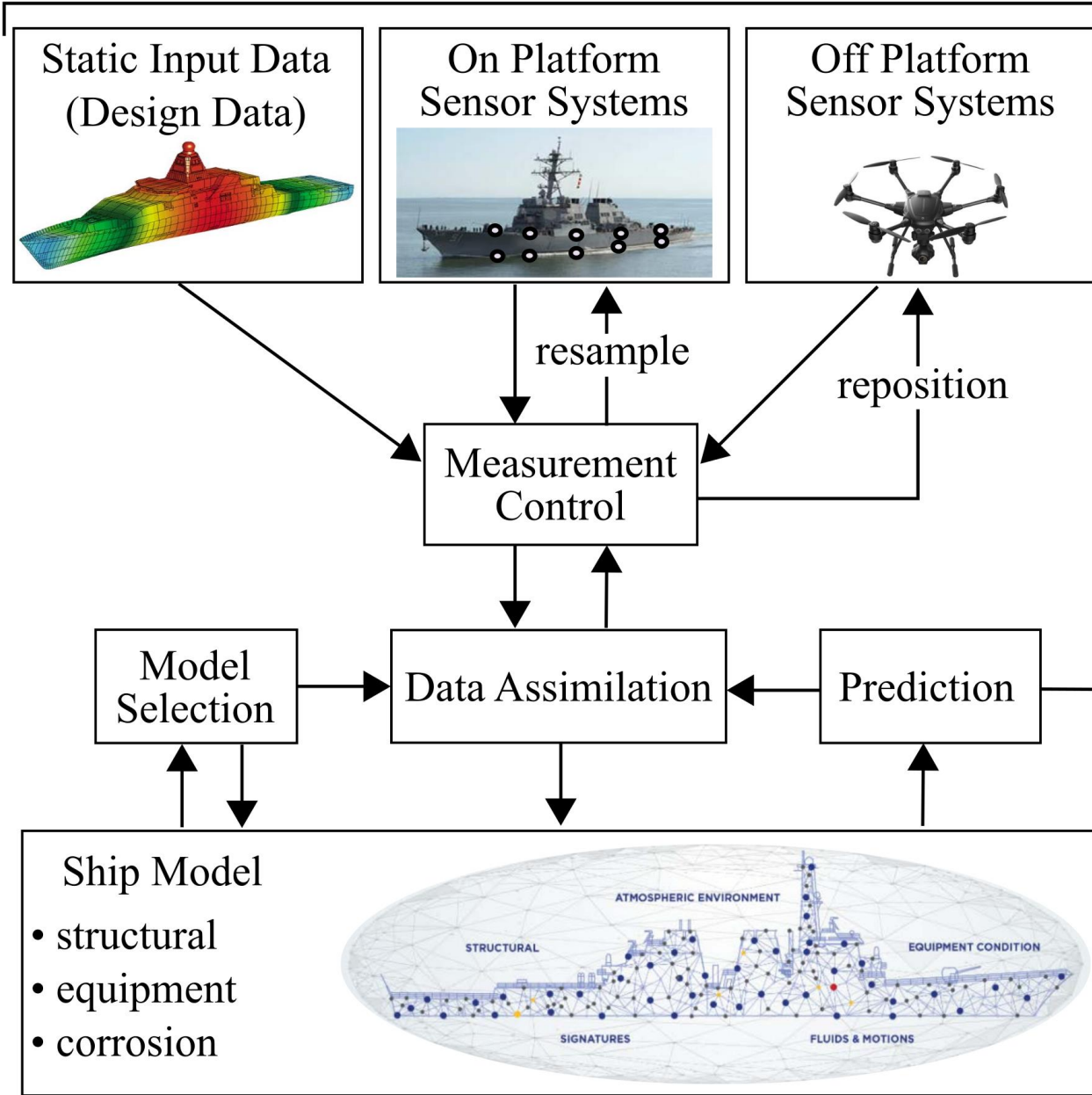

Informed Response Management

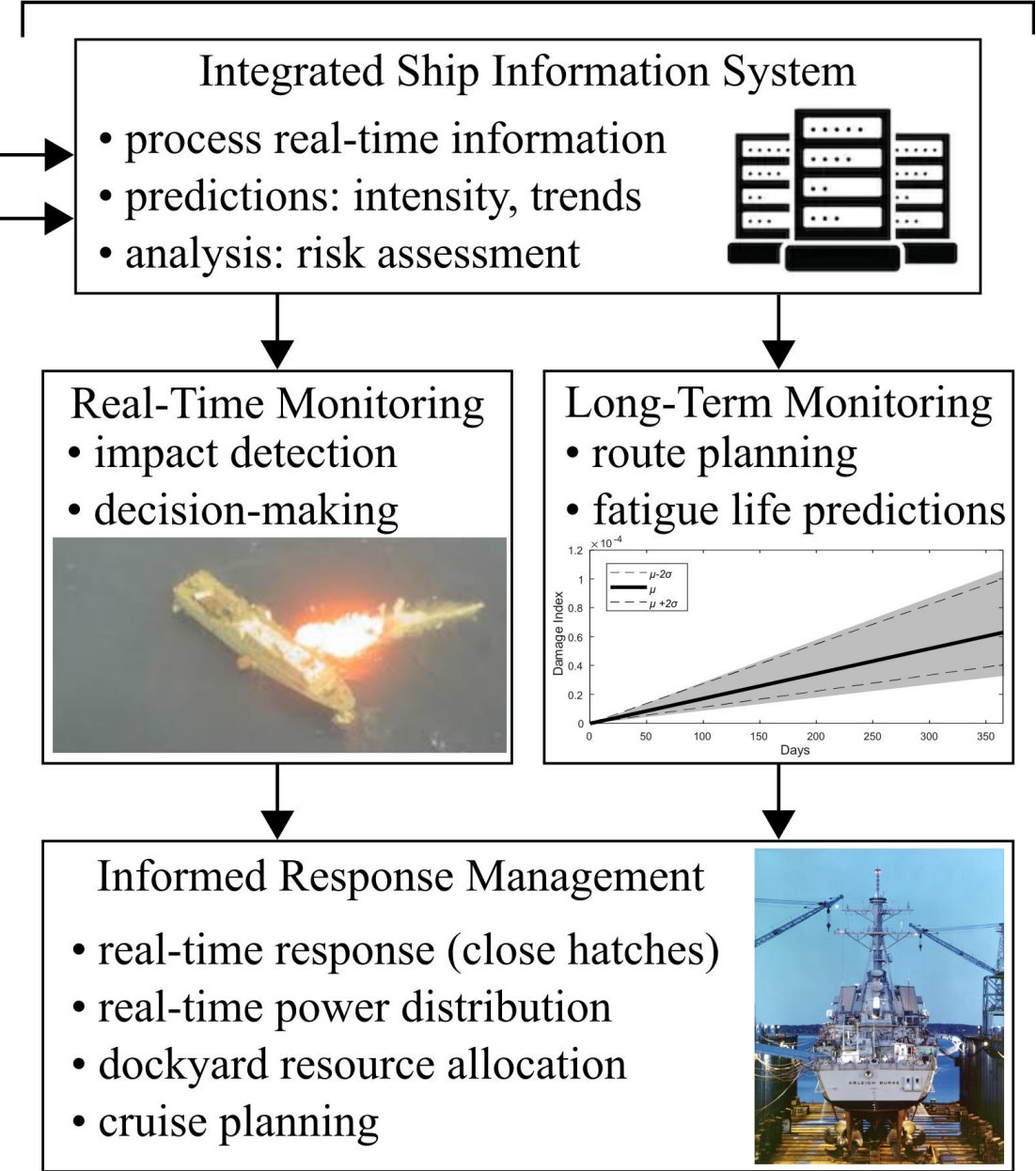

Questions?

Austin Downey

Assistant Professor

austindowney@sc.edu

me.sc.edu/Research/Downey/