



UNIVERSITY OF  
**SOUTH CAROLINA**

# **CSCE 574 ROBOTICS**

## **Sensors and Actuators**

# Robot Sensors

---

- Sensors are devices that can sense and measure physical properties of the environment,
  - e.g. temperature, luminance, resistance to touch, weight, size, etc.
  - The key phenomenon is transduction
    - Transduction (engineering) is a process that converts one type of energy to another
- They deliver *low-level* information about the environment the robot is working in.
  - Return an incomplete description of the world.



# Robot Sensors

---

- This information is **noisy** (imprecise).
- Cannot be modelled completely:
  - Reading =  $f(\text{env})$  where  $f$  is the model of the sensor
  - Finding the inverse:
    - ill posed problem (solution not uniquely defined)
    - collapsing of dimensionality leads to ambiguity



# Types of sensor

---

- General classification:
  - **active** *versus* **passive**
    - Active: emit energy in environment
      - More robust, less efficient
    - Passive: passively receive energy from env.
      - Less intrusive, but depends on env. e.g. light for camera
    - Example: stereo vision versus range finder.
  - **contact** *versus* **non-contact**



# Sensors

- **Proprioceptive Sensors**

(monitor state of robot)

- IMU (accels & gyros)
- Wheel encoders
- Doppler radar ...



- **Exteroceptive Sensors**

(monitor environment)

- Cameras (single, stereo, omni, FLIR ...)
- Laser scanner
- MW radar
- Sonar
- Tactile...



# Sensors

- Raw data processed at different levels, depending on the sensor
  - Low: electronics
  - Medium: signal processing
  - High: computation

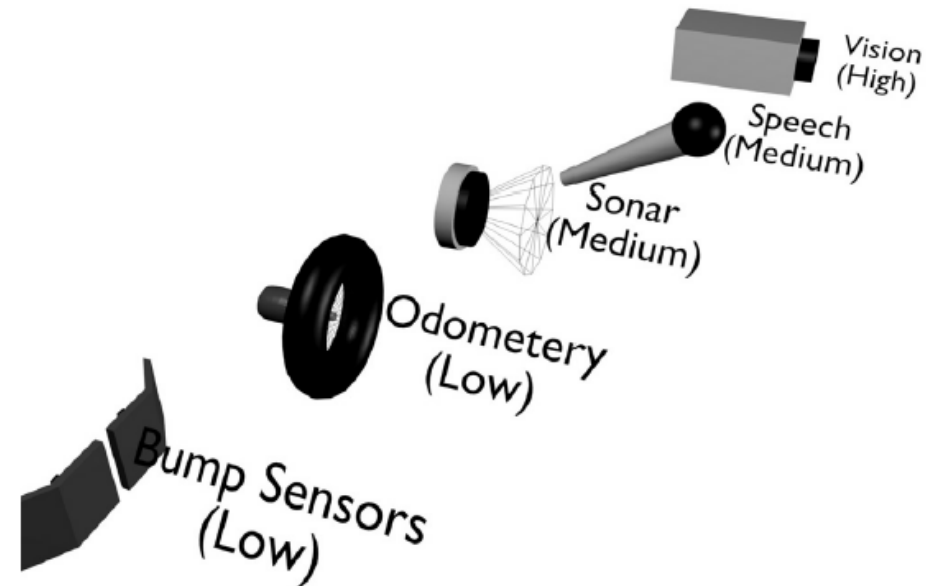

Source: [Mataric, 2007, MIT Press]

# Sensor Characteristics

---

- All sensors are characterized by various properties that describe their capabilities
  - **Sensitivity:**  
(change of output)  $\div$  (change of input)
  - **Linearity:** constancy of (output  $\div$  input)
    - Exception: logarithmic response cameras == wider dynamic range.
  - **Measurement/Dynamic range:**  
difference between min. and max.



# Sensor Characteristics

---

- **Response Time:** time required for a change in input to cause a change in the output
- **Accuracy:** difference between measured & actual
- **Repeatability:** difference between repeated measures
- **Resolution:** smallest observable increment
- **Bandwidth:** result of high resolution or cycle time





# Types of sensor

## Specific examples

- tactile
- close-range proximity
- angular position
- infrared
- Sonar
- laser (various types)
- radar
- compasses, gyroscopes
- Force
- GPS
- vision

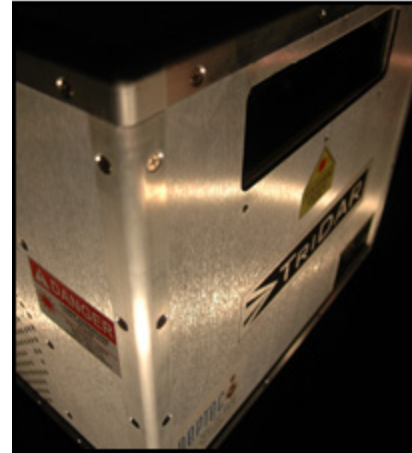

# Tactile Sensors

- There are many different technologies
  - e.g. contact closure, magnetic, piezoelectric, etc.
- For mobile robots these can be classified as
  - tactile feelers (antennae) often some form of metal wire passing through a wire loop - can be active (powered to mechanically search for surfaces)
  - tactile bumpers
    - solid bar / plate acts on some form of contact switch
    - e.g. mirror deflecting light beam, pressure *bladder*, wire loops, etc.
  - Pressure-sensitive rubber with scanning array

**“last line of defense”**

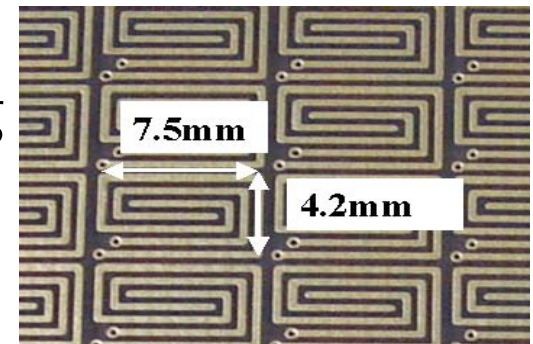

# Tactile Sensors (more)

---

- Vibrissae/whiskers of rats
  - Surface texture information.
  - Distance of deflection.
  - Blind people using a cane.



# Proximity Sensors

---

- Tactile sensors allow obstacle *detection*
  - proximity sensors needed for true obstacle *avoidance*
- Several technologies can detect the presence of particular fields without mechanical contact
  - magnetic reed switches
    - two thin magnetic strips of opposite polarity not quite touching
    - an external magnetic field closes the strip & makes contact



# Proximity Sensors

---

- Hall effect sensors
  - small voltage generated across a conductor carrying current  $V_H \propto I \times B$
- inductive sensors, capacitive sensors
  - inductive sensors can detect presence of metallic objects
  - capacitive sensors can detect metallic or dielectric materials



# Infrared Sensors

---

- Infrared sensors are probably the simplest type of non-contact sensor
  - widely used in mobile robotics to avoid obstacles
- They work by
  - emitting infrared light
    - to differentiate emitted IR from ambient IR (e.g. lights, sun, etc.), the signal is modulated with a low frequency (100 Hz)
  - detecting any reflections off nearby surfaces
- In certain environments, with **careful calibration**, IR sensors can be used for measuring the distance to the object
  - requires uniform surface colours and structures



# Infrared Sensors (Sharp)

- Measures the return angle of the infrared beam.

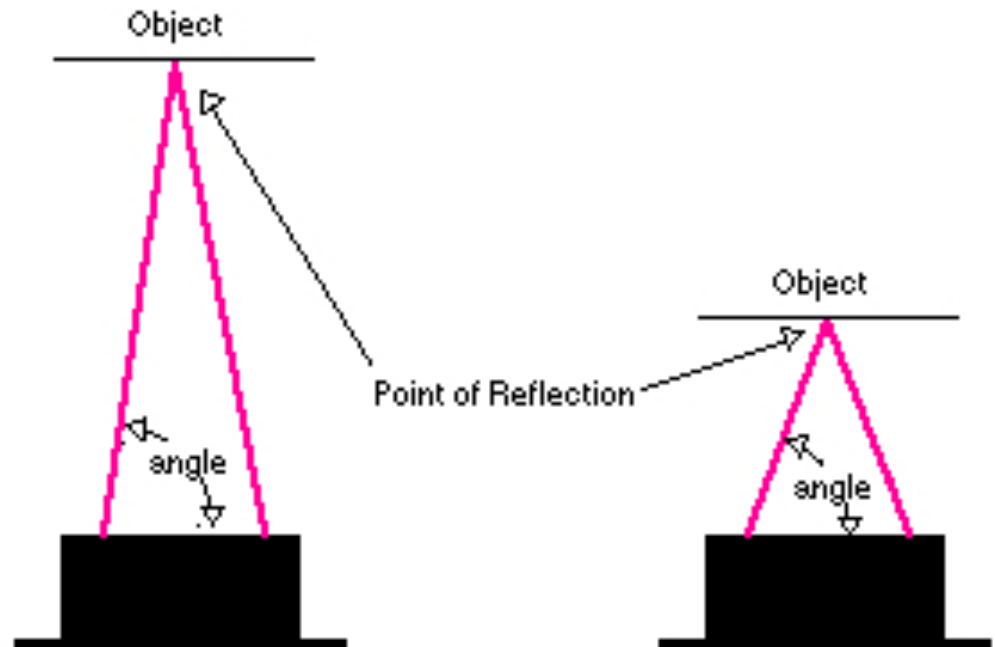

# Infrared Problems

---

- If the IR signal is detected, it is safe to assume that an object is present
- However, the absence of reflected IR does not mean that no object is present!
  - “Absence of evidence is not evidence of absence.”  
C. Sagan
  - certain dark colours (black) are almost invisible to IR
  - IR sensors are not absolutely safe for object detection
- In realistic situations (different colours & types of objects) there is no accurate distance information
  - it is best to avoid objects as soon as possible
- IR are short range
  - typical maximum range is 50 to 100 cm





# Sonar Sensors

- The fundamental principle of robot sonar sensors is the same as that used by bats
  - emit a chirp (e.g. 1.2 milliseconds)
    - a short powerful pulse of a range of frequencies of sound
  - its reflection off nearby surfaces is detected
- As the speed of sound in air is known ( $\approx 330 \text{ m}\cdot\text{s}^{-1}$ ) the distance to the object can be computed from the elapsed time between chirp and echo
  - minimum distance =  $165 t_{chirp}$  (e.g. 21 cm at 1.2 ms)
  - maximum distance =  $165 t_{wait}$  (e.g. 165 m at 1 s)
- Usually referred to as *ultrasonic sensors*

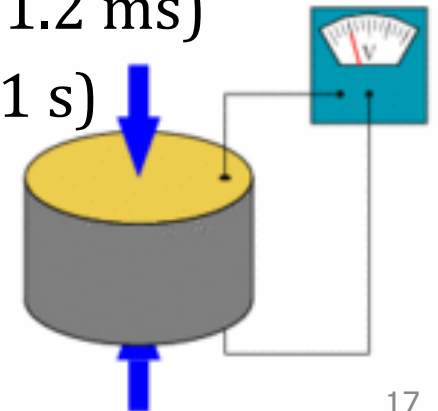

# Sonar Problems

---

- There are a number of problems and uncertainties associated with readings from sonar sensors
  - it is difficult to be sure in which direction an object is because the 3D sonar beam spreads out as it travels
  - *specular reflections* give rise to erroneous readings
    - the sonar beam hits a smooth surface at a shallow angle and so reflects away from the sensor
    - only when an object further away reflects the beam back does the sensor obtain a reading - *but distance is incorrect*
  - arrays of sonar sensors can experience *crosstalk*
    - one sensor detects the reflected beam of another sensor
  - the speed of sound varies with air temp. and pressure
    - a 16° C temp. change can cause a 30cm error at 10m!



# Laser Range Finders

---

- Laser range finders commonly used to measure the *distance, velocity* and *acceleration* of objects
  - also known as *laser radar* or *lidar*
- The operating principle is the same as sonar
  - a short pulse of (laser) light is emitted
  - the time elapsed between emission and detection is used to determine distance (using the speed of light)
- Due to the shorter wavelengths of lasers, the chance of specular reflections is much less
  - accuracies of millimetres (16 - 50mm) over 100m
  - 1D beam is usually swept to give a 2D planar beam
- May not detect transparent surfaces (e.g. glass!) or dark objects



# RADAR

---

- Radar usually uses electromagnetic energy in the 1 - 12.5 GHz frequency range
  - this corresponds to wavelengths of 30 cm - 2 cm
    - microwave energy
    - unaffected by fog, rain, dust, haze and smoke
- It may use a pulsed time-of-flight methodology of sonar and lidar, but may also use other methods
  - continuous-wave phase detection
  - continuous-wave frequency modulation
- Continuous-wave systems make use of Doppler effect to measure relative velocity of the target



# Angular Position: Rotary Encoder

- Potentiometer
  - Used in the Servo on the boebots
- Optical Disks (Relative)
  - Counting the slots
  - Direction by having pairs of emitters/receivers out of phase: Quadrature decoding
  - Can spin very fast: 500 kHz

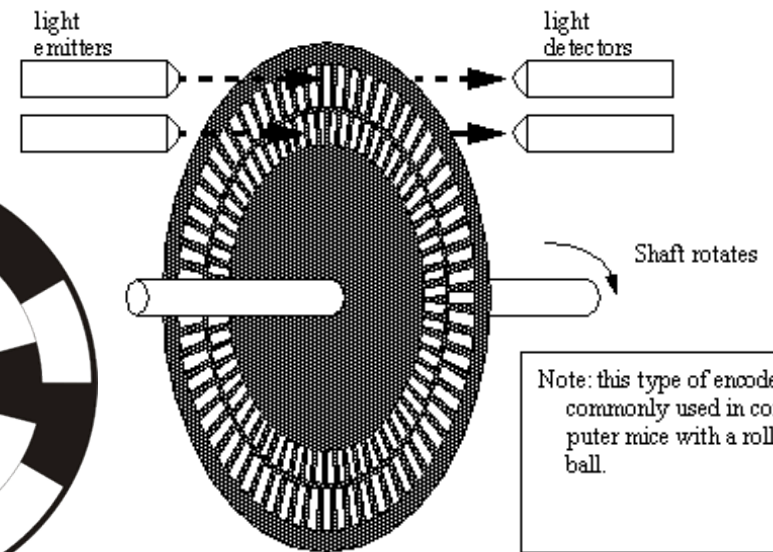
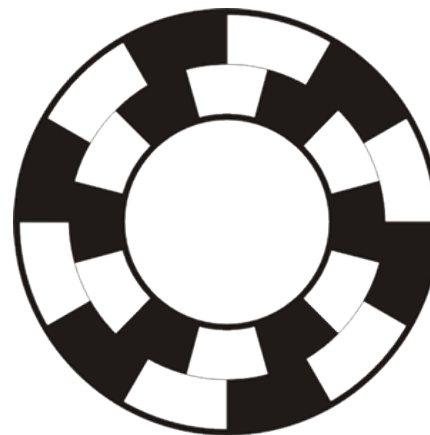
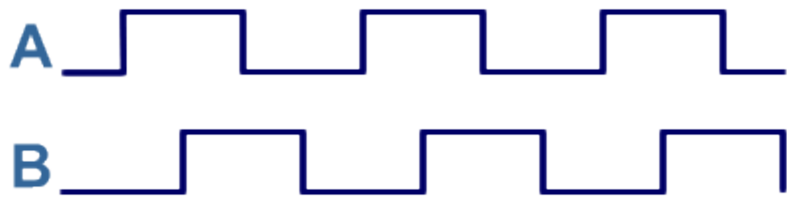
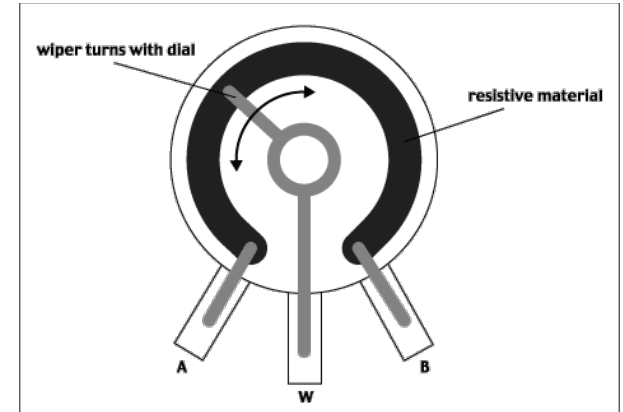

# Angular Position: Rotary Encoder

---

- Optical Disks (Absolute)
  - Grey encoding for absolute:
    - 0:0000, 1:1000, 2:1100, 3:0100, 4:0110,
    - 5:1110, 6:1010, 7:0010, 8:0011
    - 9:1011, 10:1111, 11:0111, 12:0101, 13:1101, 14:1001, 15:0001

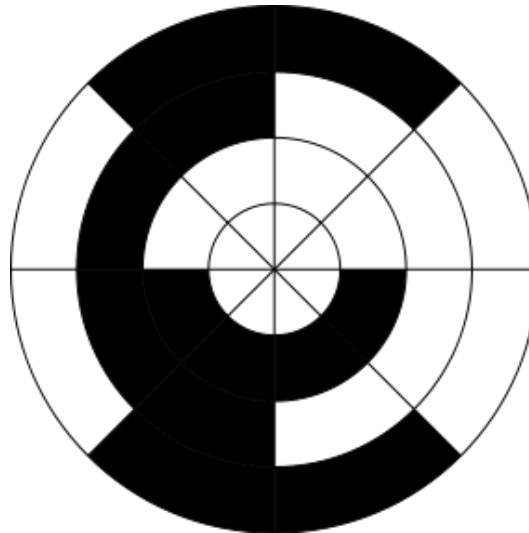

# Compass Sensors

---

- Compass sensors measure the horizontal component of the earth's magnetic field
  - some birds use the vertical component too
- The earth's magnetic field is very **weak** and **non-uniform**, and **changes over time**
  - indoors there are likely to be many other field sources
    - steel girders, reinforced concrete, power lines, motors, etc.
  - an accurate absolute reference is unlikely, but the field is approx. constant, so can be used for local reference



# Gyroscopes

---

- A gyroscope is a spinning wheel with most of its mass concentrated in the outer periphery
  - e.g. a bicycle wheel
- Due to the law of *conservation of momentum*
  - the spinning wheel will stay in its original orientation
  - a force is required to rotate the gyroscope
- A gyro. can thus be used to maintain orientation or to measure the rate and direction of rotation
- In fact there are different types of mechanical gyro.
  - and even optical gyro's with no moving parts!
    - these can be used in e.g. space probes to maintain orientation





# Vibrating Structure Gyroscopes

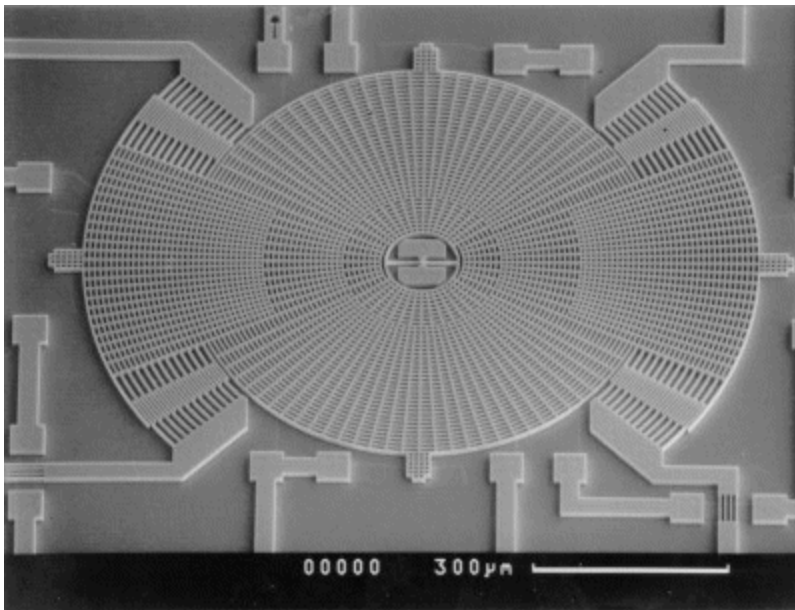

**MEMS**

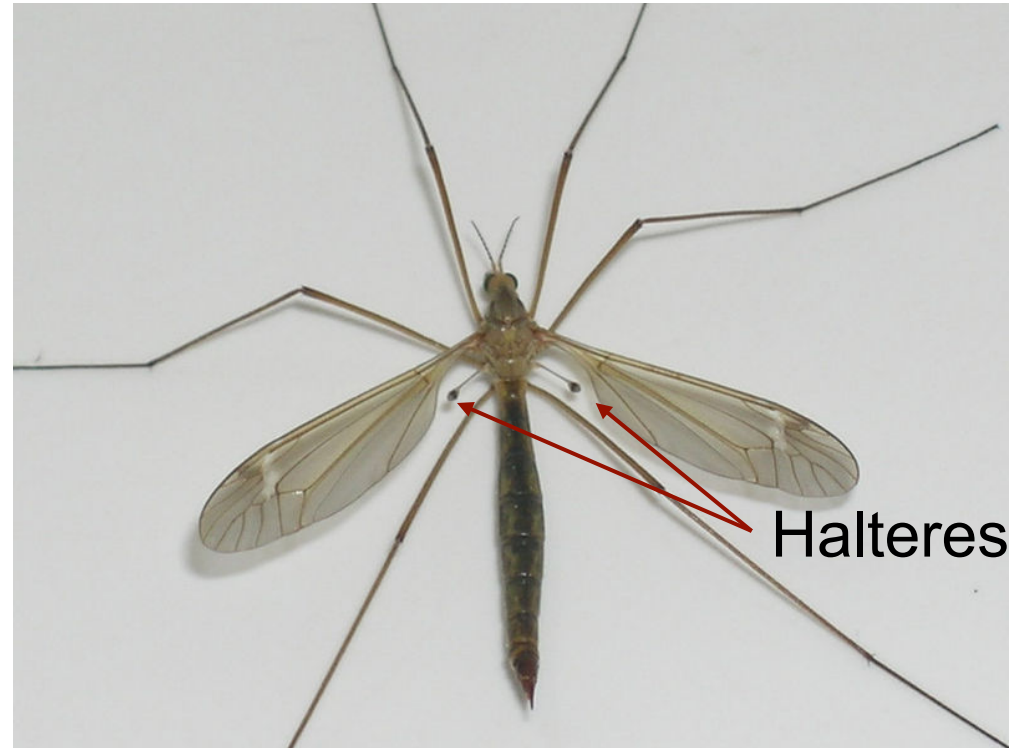

# Ring gyro's

---

- Use standing waves set up
  - between mirrors (laser ring gyro)
  - within a fiber optic cable (fibre optic ring gyro)
- Measure rotation by observing beats in standing wave as the mirrors "rotate through it".



# IMU's

- Gyro, accelerometer combination.
- Typical designs (e.g. 3DM-GX1™) use tri-axial gyros to track dynamic orientation and tri-axial DC accelerometers along with the tri-axial magnetometers to track static orientation.
- The embedded microprocessors contains programmable filter algorithms, which blend these static and dynamic responses in real-time.

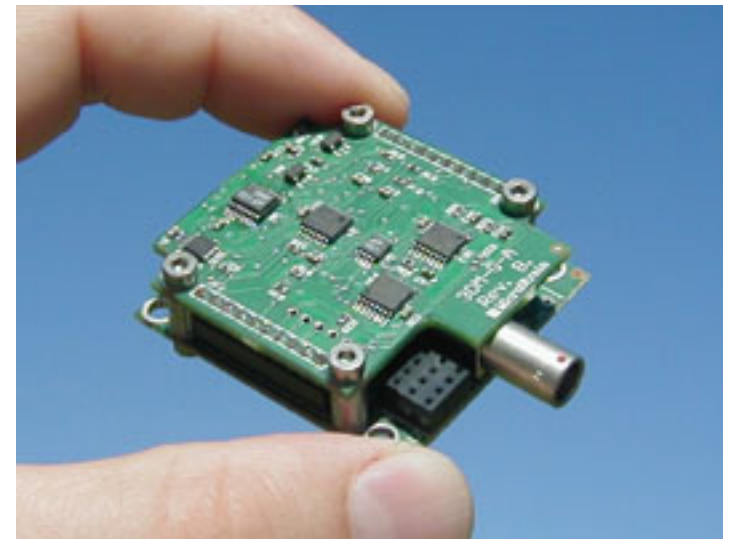

# GPS

---

- GPS uses a constellation of between 24 and 32 Medium Earth Orbit satellites.
- Satellite broadcast their position + time.
- Use travel time of 4 satellites and trilateration.
- Suffers from “canyon” effect in cities.



# WiFi

---

- Using the SSID and database.



# Odor sensing

---

Smell is ubiquitous in nature  
... both as a active and a passive sensor.  
Why is it so important?

Advantages: evanescent, controllable, multi-valued,  
useful.

## References:

- [1] T. Hayes, A. Martinoli, and R. M. Goodman. “Swarm Robotic Odor Localization: Off-Line Optimization and Validation with Real Robots”. Special issue on Biological Robotics, *Robotica*, Vol. 21, Issue 4, pp. 427-441, 2003. © Cambridge University Press
- [2] T. Yamanaka, R. Matsumoto, and T. Nakamoto, “Fundamental study of odor recorder for multi-component odor using recipe exploration method based on singular value decomposition”, *IEEE Sensors Journal*, Vol. 3, Issue 4, 2003, pp. 468-474.



# Interfacing

---

- Protocols
  - RS-232
  - I<sup>2</sup>C
  - Ethernet
  - USB
  - ...
- Each of them has different characteristics, e.g., bandwidth, power consumption, maximum cable length
- Read the specifications to interpret correctly the data



# ROS drivers

---

- E.g., laser

[https://github.com/ros-drivers/urg\\_  
blob/indigo-devel/src/urg\\_node\\_driv](https://github.com/ros-drivers/urg/blob/indigo-devel/src/urg_node_driver)





# What is an actuator?

---

- Device for moving or controlling a system.
- “Robot Muscles”



# Hydraulic Actuators

---

- Pros:
  - Powerful
  - Fast
  - Stiff
- Cons
  - Messy
  - Maintenance
  - External Pump



# Hydraulic Actuator Application

---

- BigDog from Boston Dynamics



# Pneumatic Actuators

---

- Pros:
  - Powerful
  - Cheap
- Cons
  - Soft/Compliant
  - External Compressor

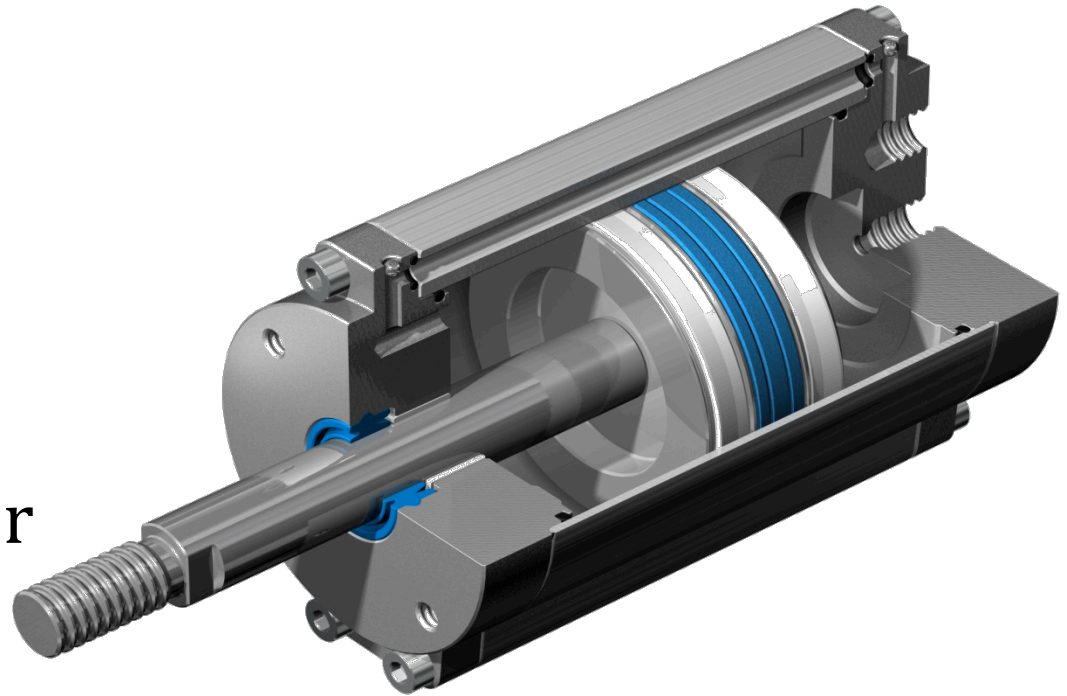



# Pneumatic Actuators

- 3D Biped ('89-'95) from MIT Leg Lab

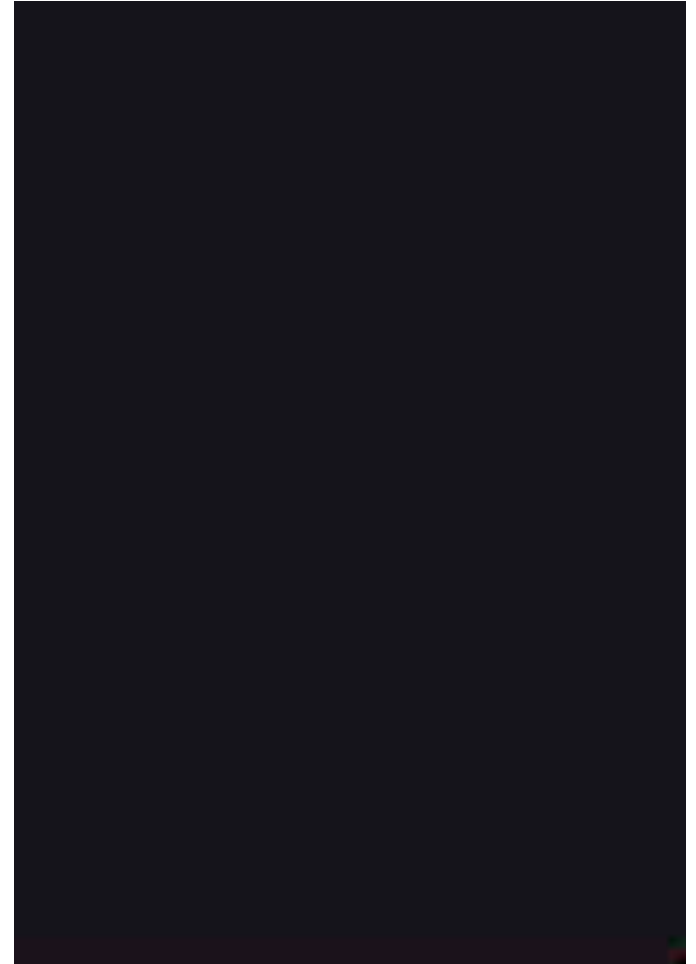
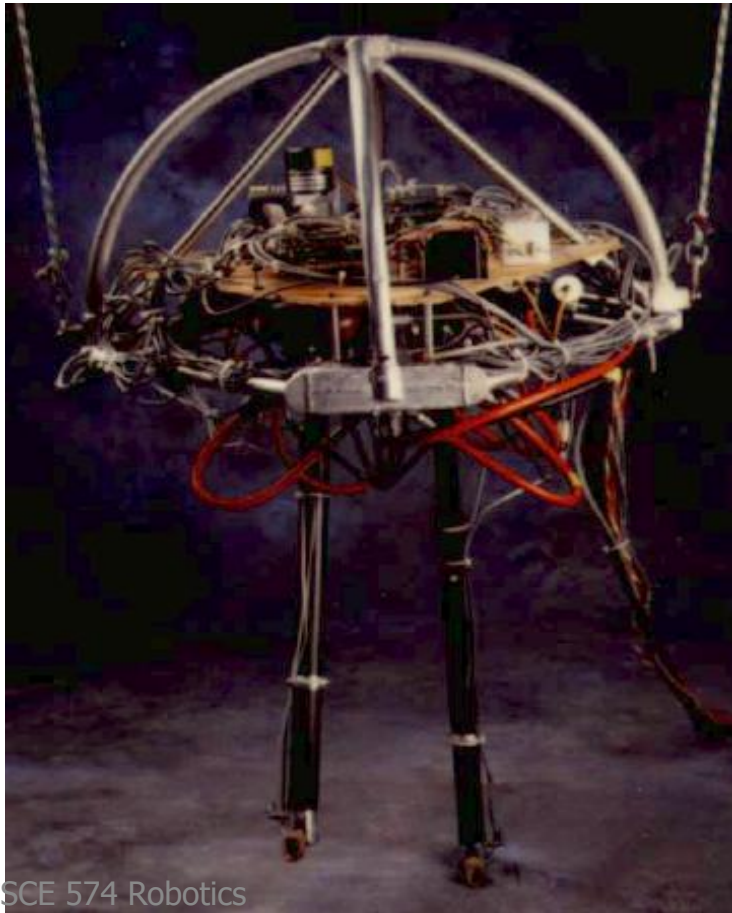

# Air Muscle

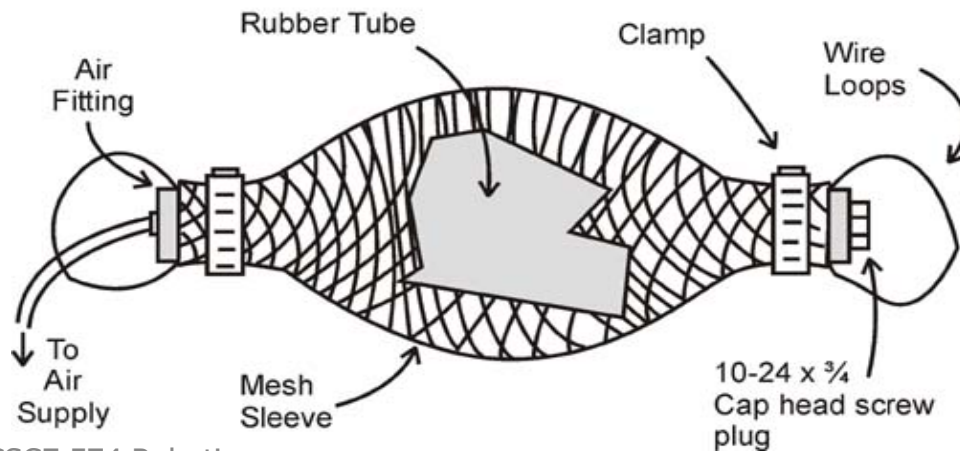
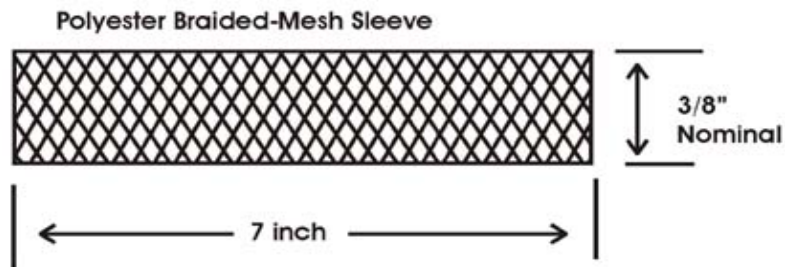
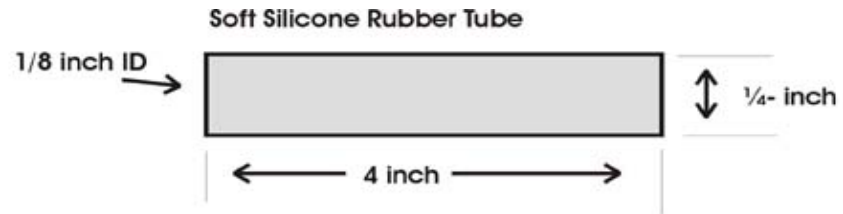

# Air Muscle Application

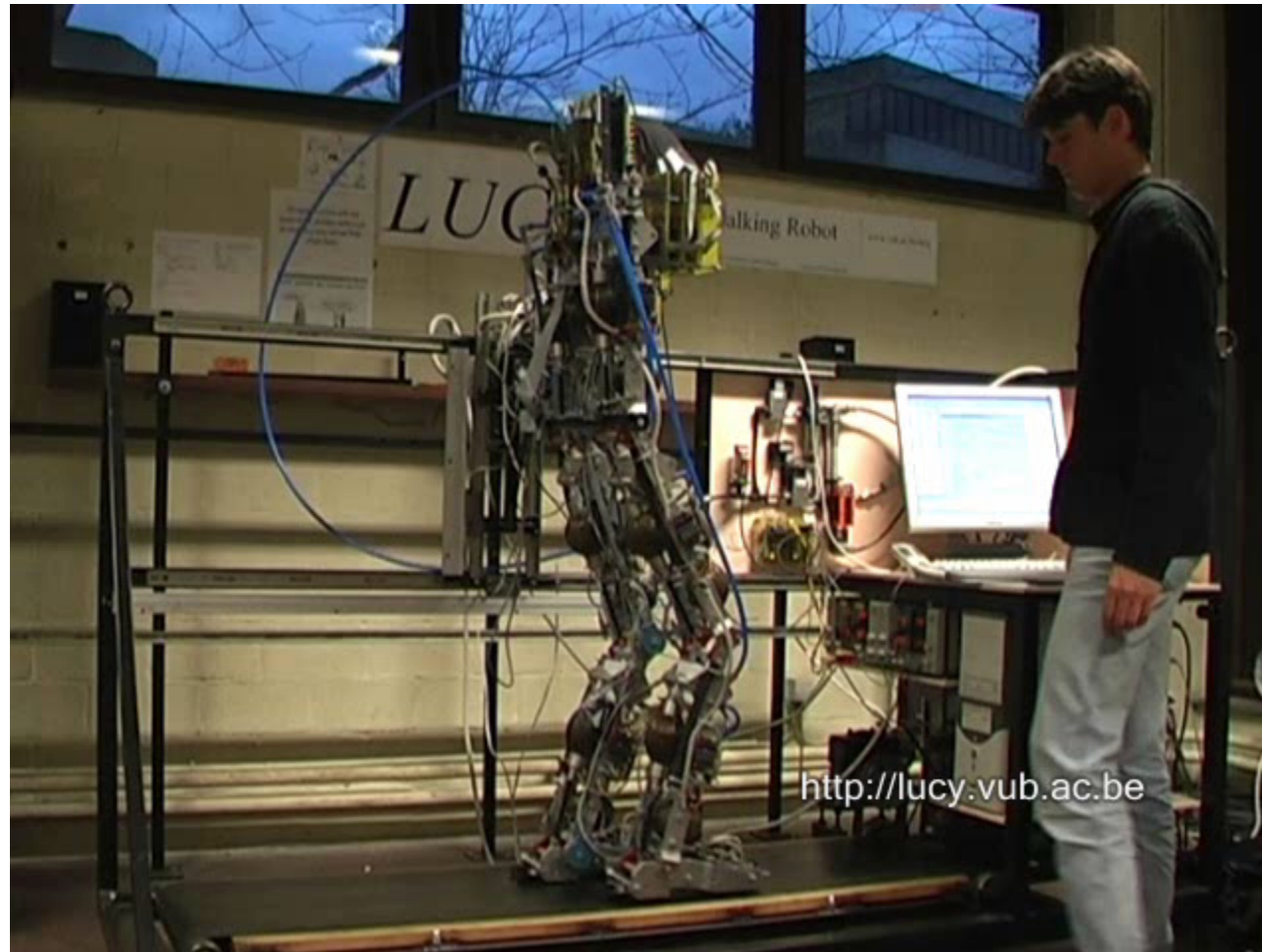

# Air Muscle Application

---





# Piezoelectric Actuator

- Pros
  - Very small motions possible at high speeds
  - Low-powered
- Cons
  - Short actuation
  - High voltages
  - Expensive
  - Fragile

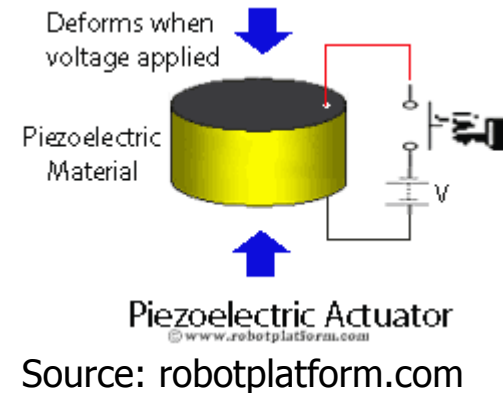

Folded millirobots (2008)

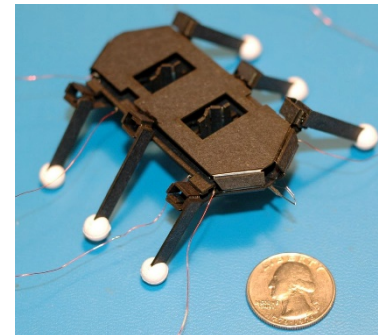

Source: robotics.eecs.berkeley.edu/  
~ronf

# Piezoelectric Actuator

---

**The RoboBee is a miniature robot  
that has long been able to fly.**



# Shape Memory Alloy Actuators

- Works by warming and cooling Nitinol wires.
- Pros:
  - Light
  - Powerful
- Cons:
  - Slow (cooling)

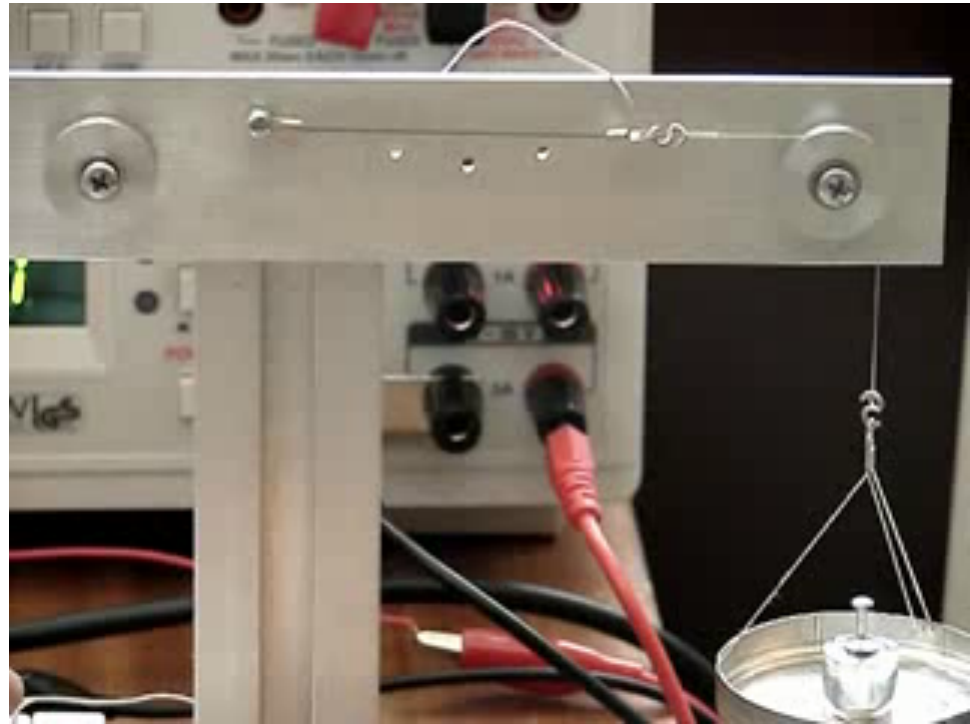

# Stiquito

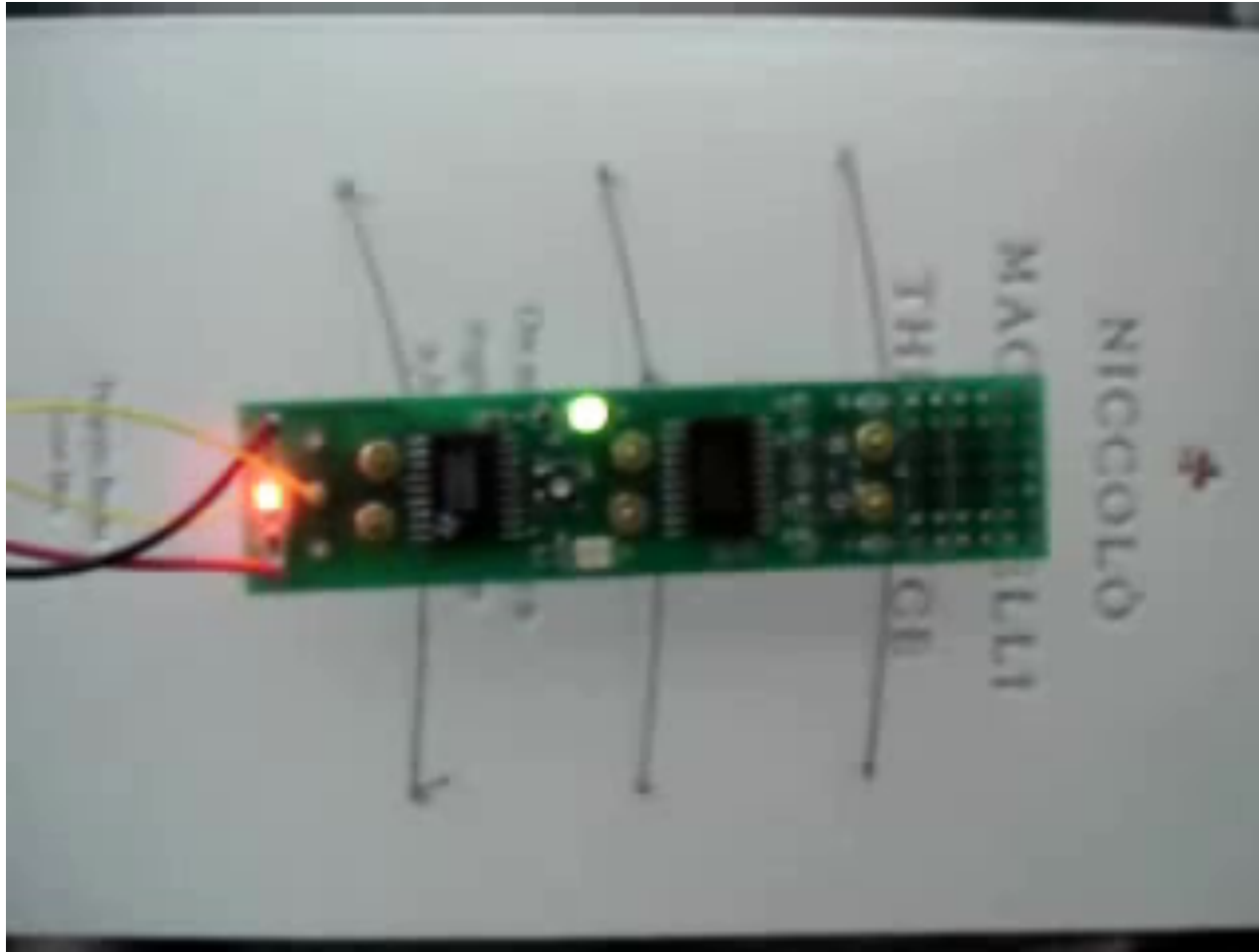

Jonathan Mills, Indiana University



# Electric Actuators

- Pros
  - Better position precision
  - Well understood
  - No separate power source
  - Cheap
- Cons
  - Heavy
  - Weaker/slower than hydraulics
  - Cooling issue



# Electric Actuators

---

- Stepper motors
- DC motors
  - Servos
    - Continuous
    - Position
- Others (not discussed)
  - Linear actuators
  - AC motors



# Stepper Motor Basics

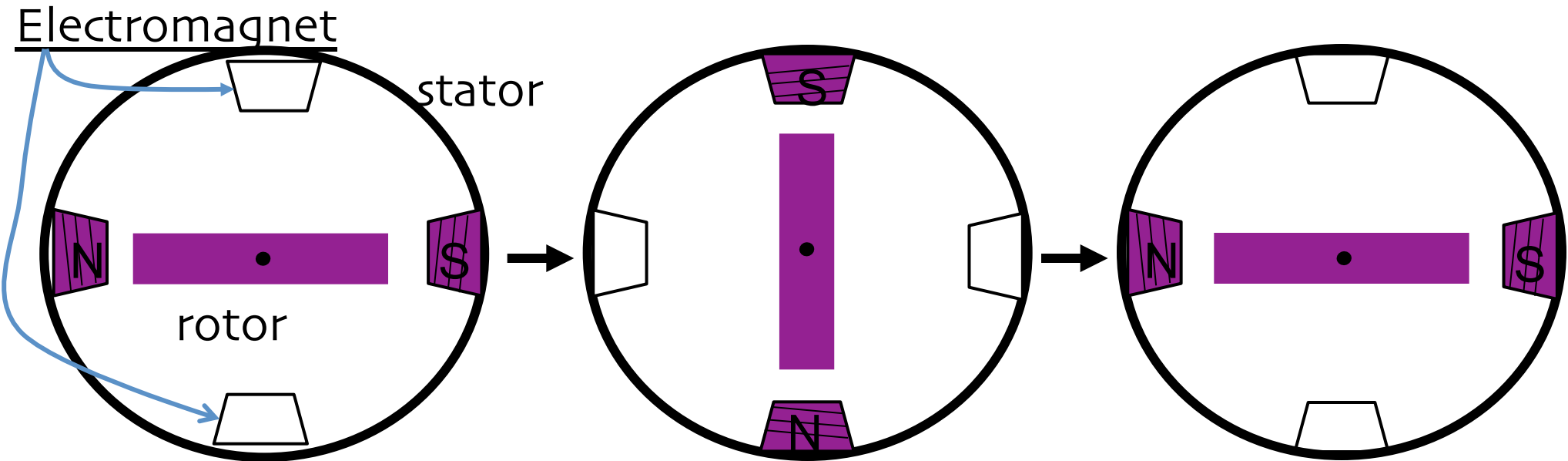

Stator: made out of coils of wire called “winding”

Rotor: magnet rotates on bearings inside the stator

- Direct control of rotor position (no sensing needed)
- May oscillate around a desired orientation (resonance at low speeds)
- Low resolution

printers  
computer drives



# Increased Resolution

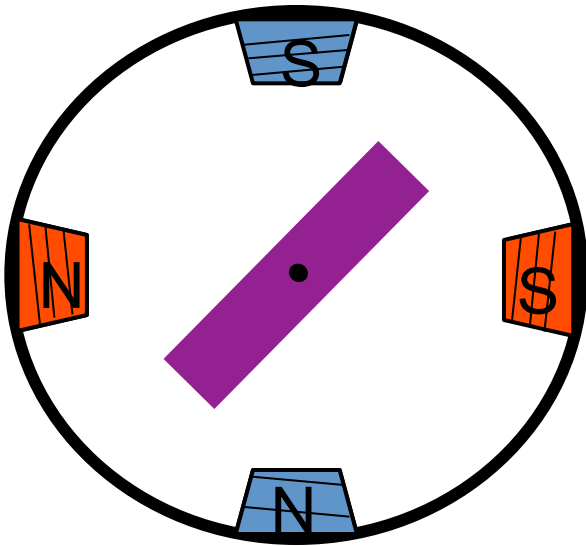

Half stepping

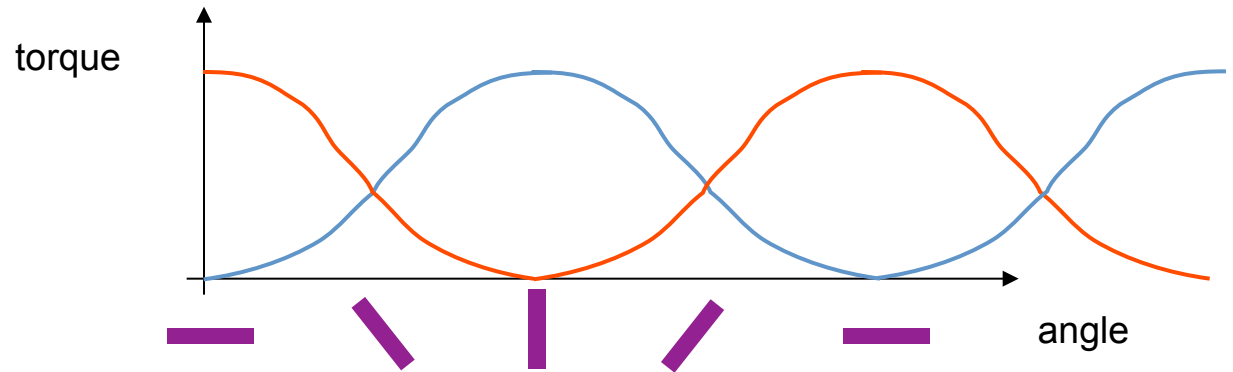



# Increased Resolution

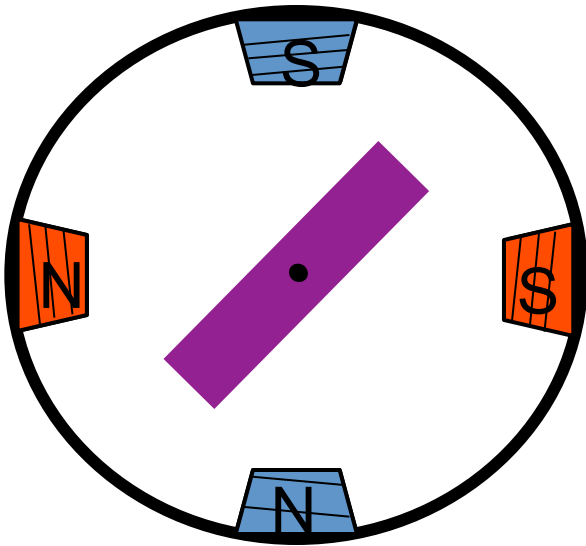

Half stepping

More teeth on rotor or stator

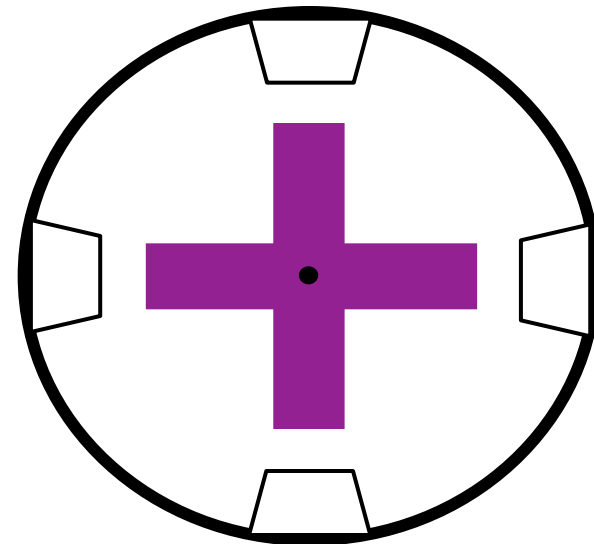

# Increased Resolution

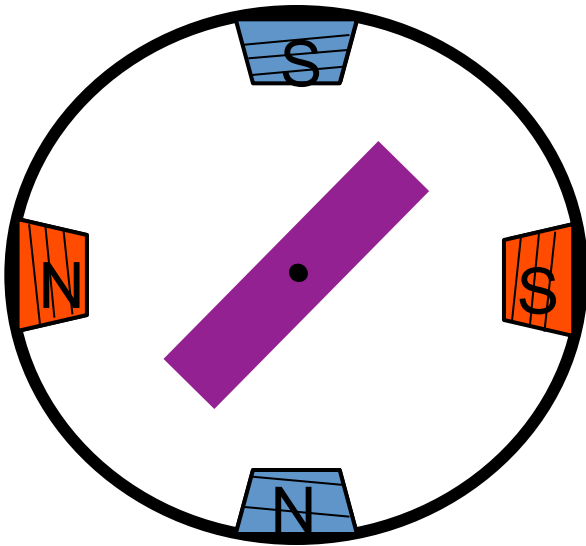

Half stepping

More teeth on rotor or stator

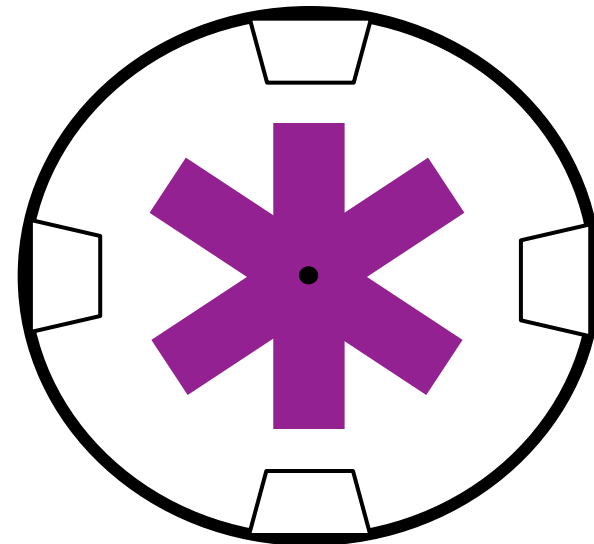

# More Teeth on Rotor

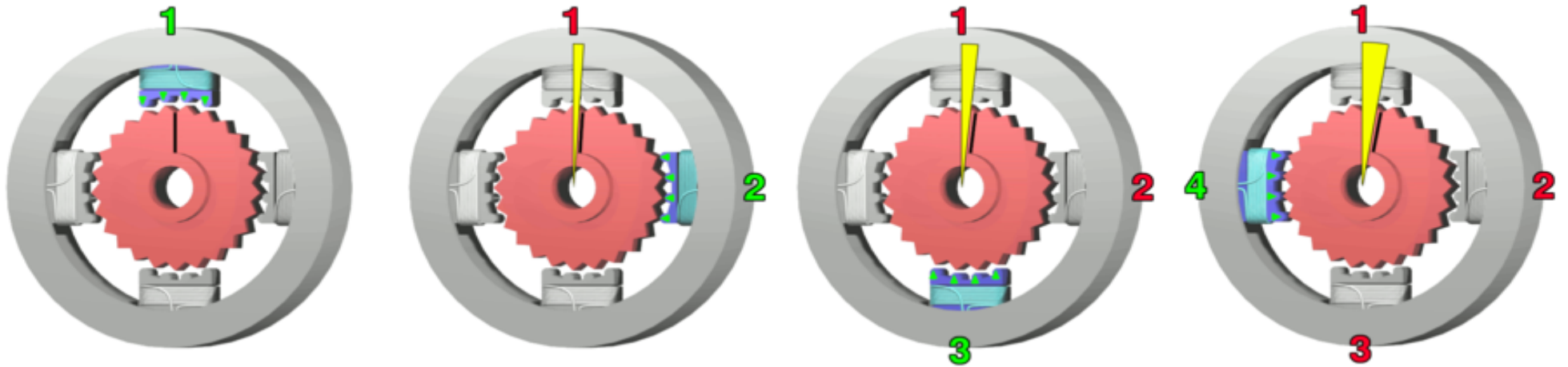

# Stepper Motors

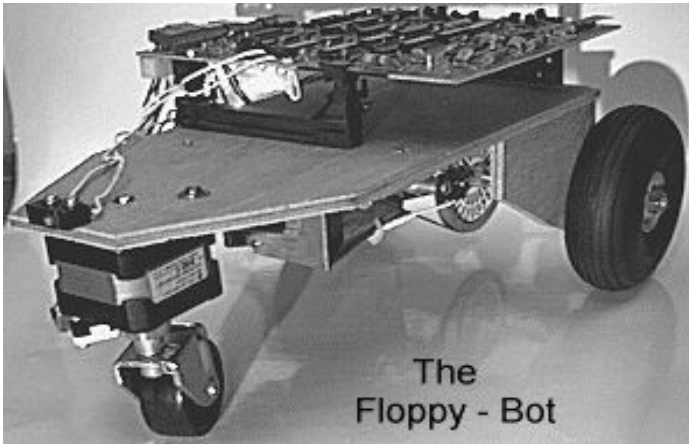

- Pros:
  - Direct position control
  - Precise positioning
  - Easy to control

- Cons:
  - Oscillations
  - Low torque at high speeds



# DC motors -- exposed !

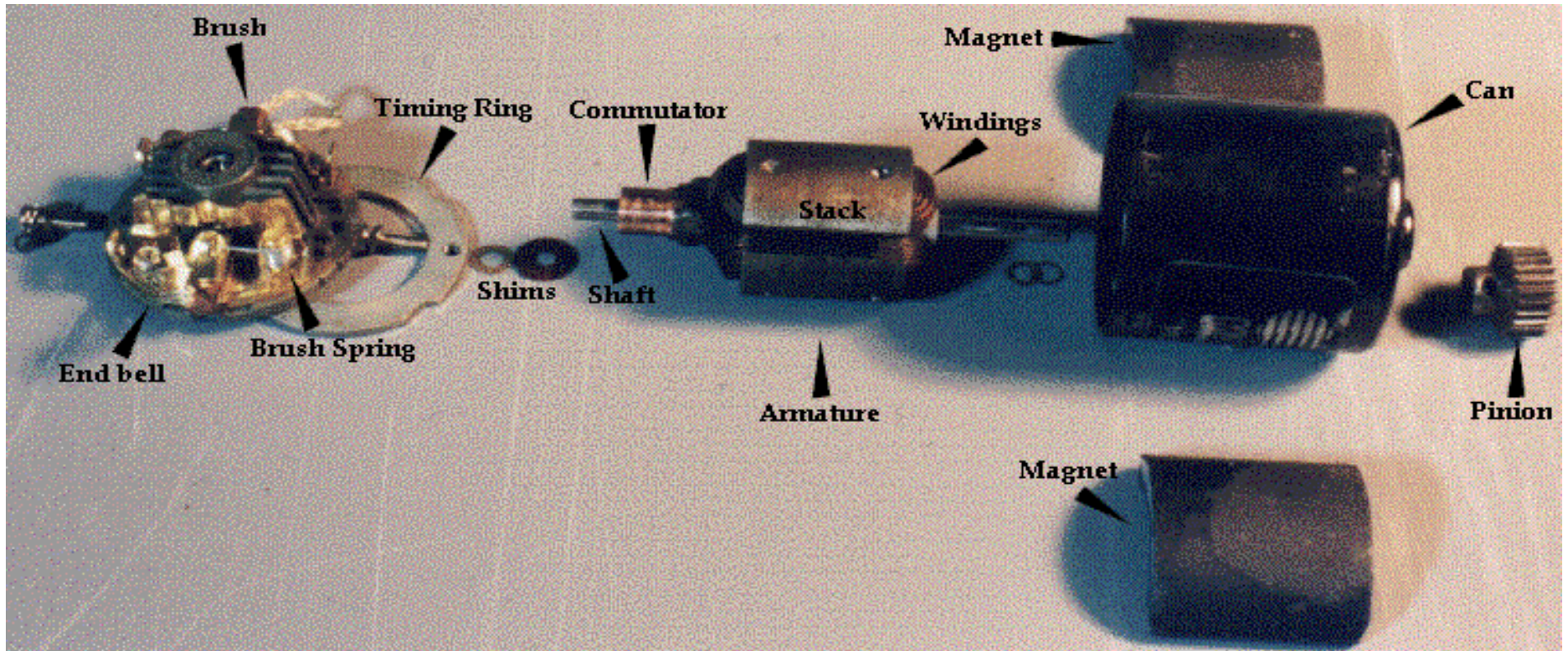

# DC motor basics

permanent magnets

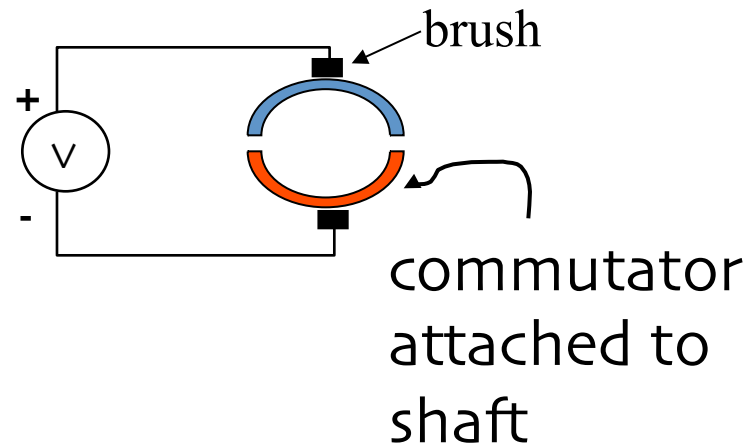
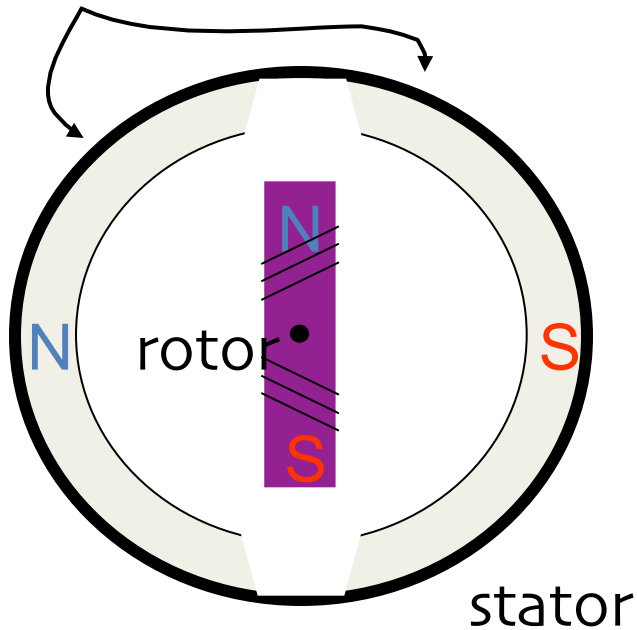



# DC motor basics

permanent magnets

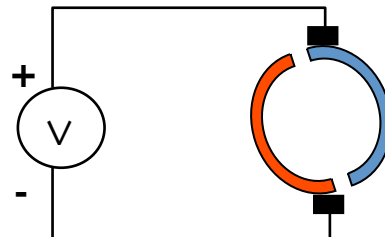
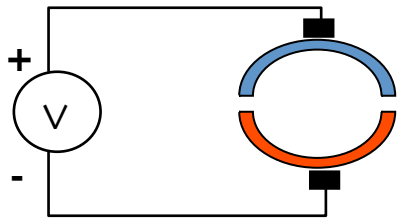
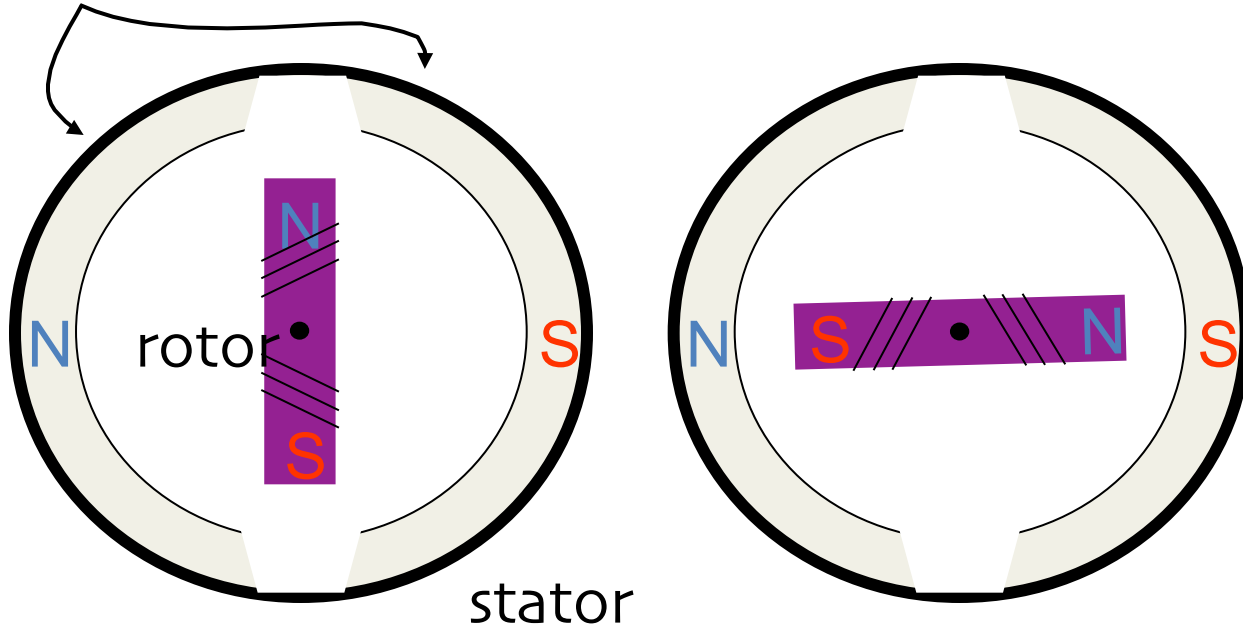

# DC motor basics

permanent magnets

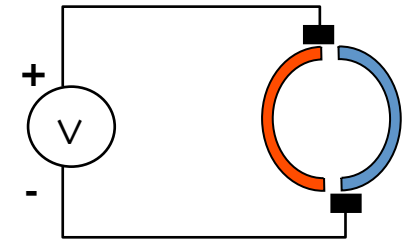
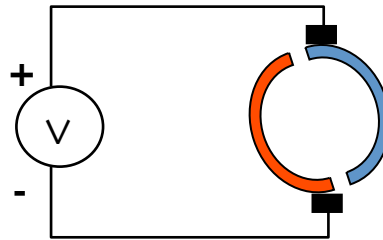
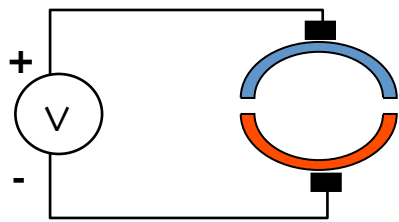
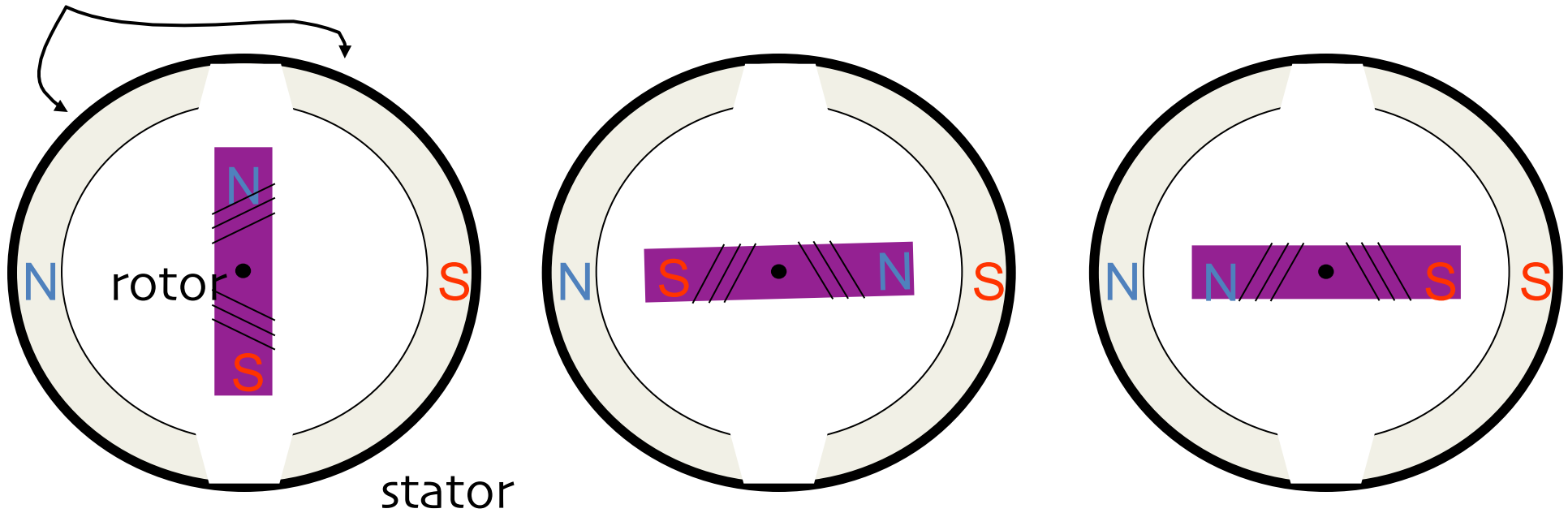



# DC motor torque $\tau$

$\tau$  = torque

$I$  = current

$$\tau \propto I$$

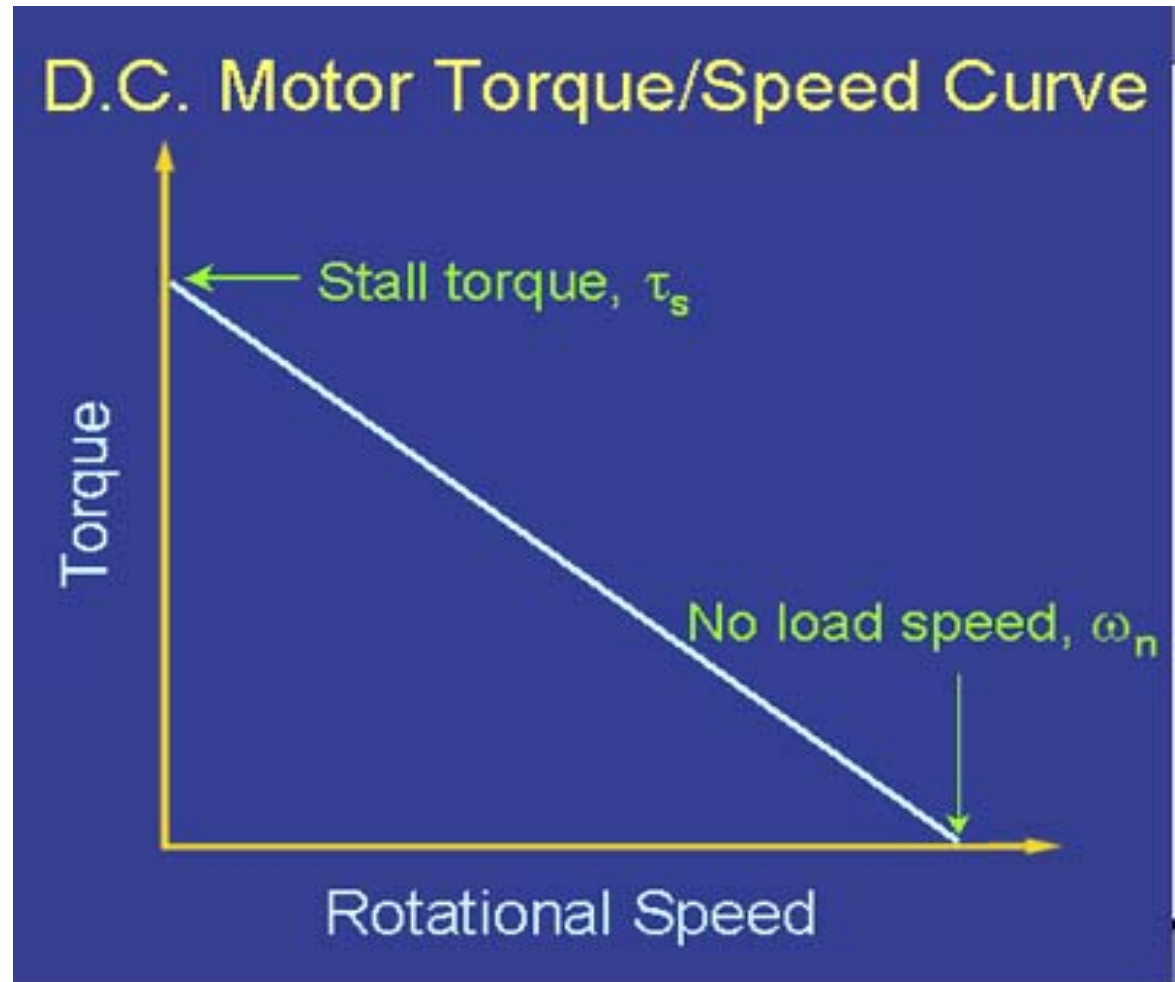

# Processing

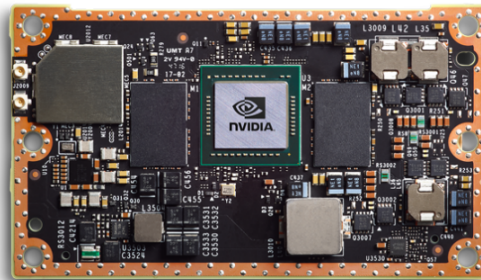
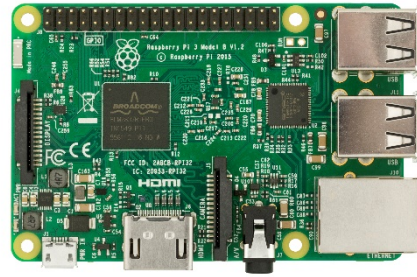
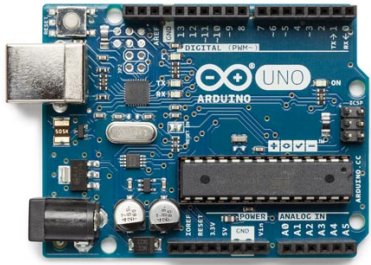

# Processing (Example)

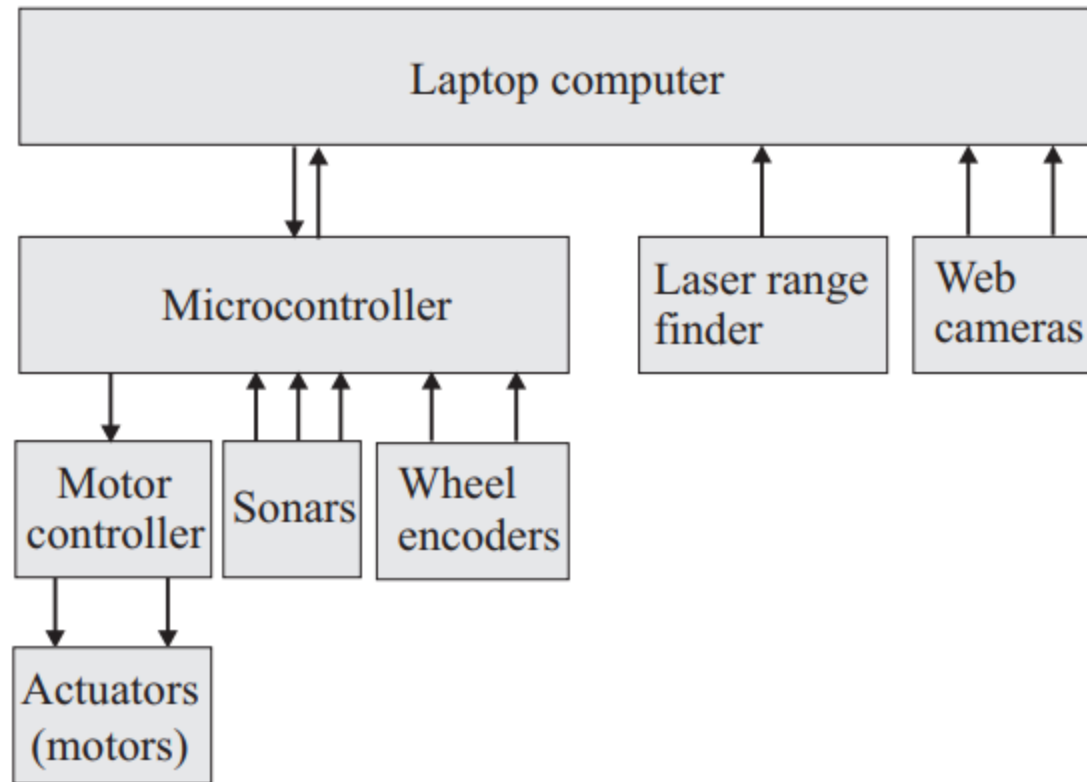

# Processing (Example)

---

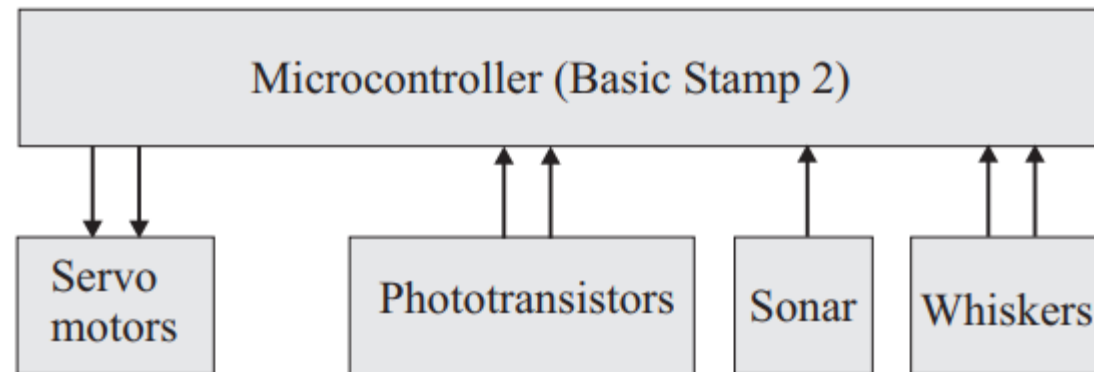

# Communication

---

- Tethered
- Untethered
  - Radio modems
  - 802.11 Wireless networks
  - Infrared
  - RC
  - Bluetooth
  - GSM/GPRS
  - Acoustic



# Summary

---

- Hardware for
  - Sensing
  - Locomotion
  - Reasoning
  - Communication

