



UNIVERSITY OF
SOUTH CAROLINA

CSCE 574 ROBOTICS

Configuration Space

Configuration Space

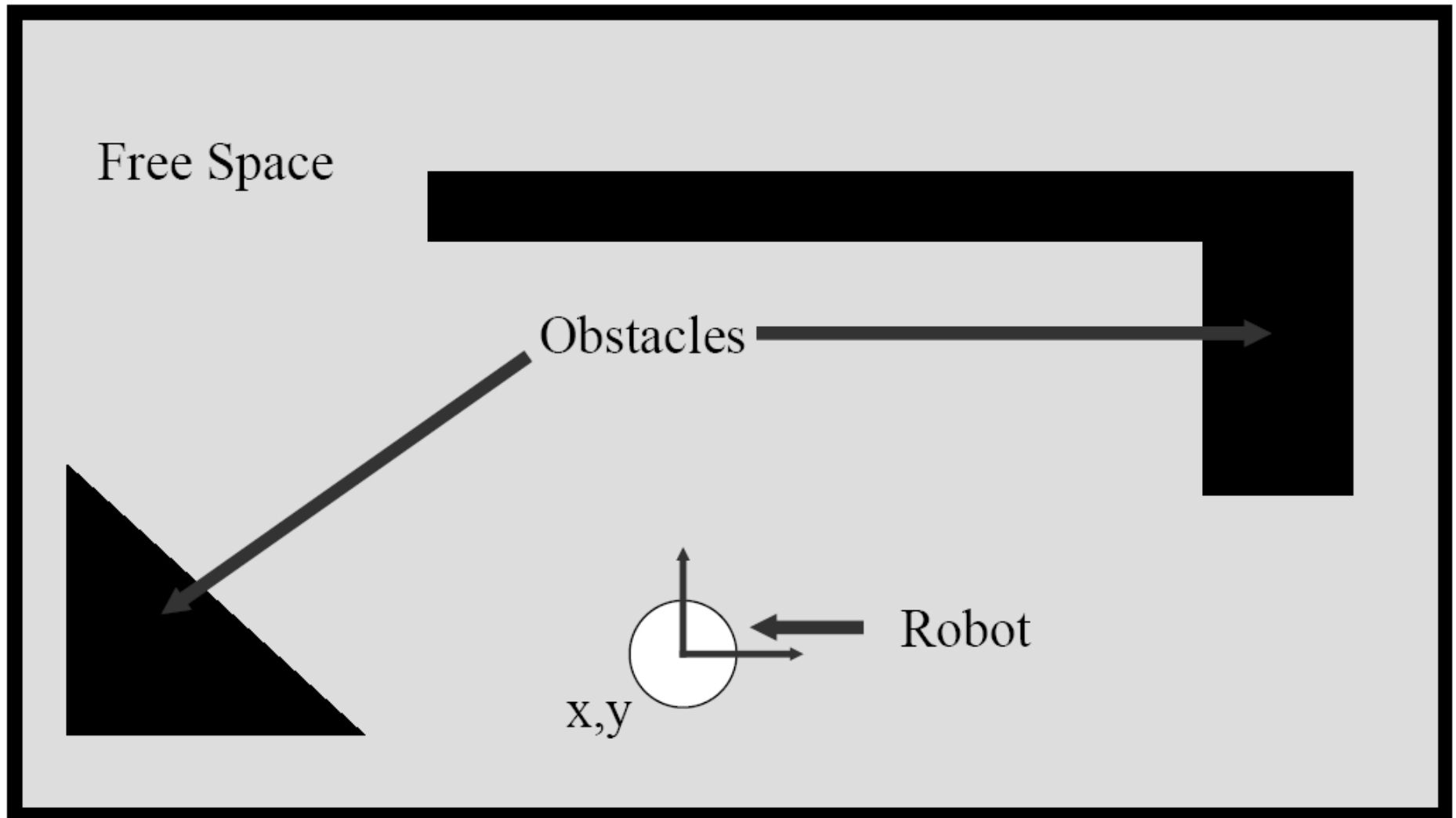

Configuration Space

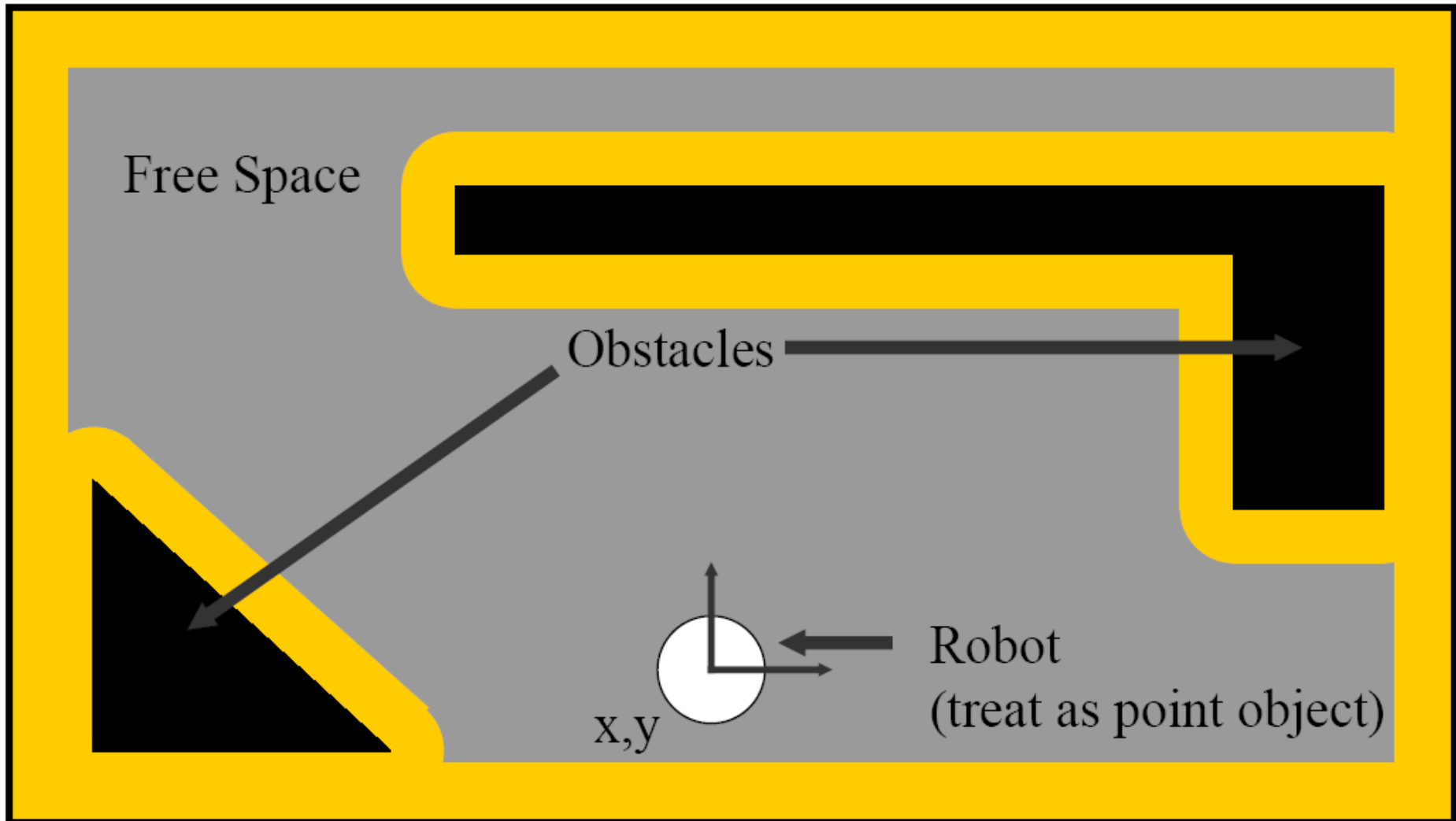

Definition

- A robot **configuration** is a specification of the positions of all robot points relative to a fixed coordinate system
- Usually a configuration is expressed as a "**vector**" of position/orientation parameters



What is a Path?

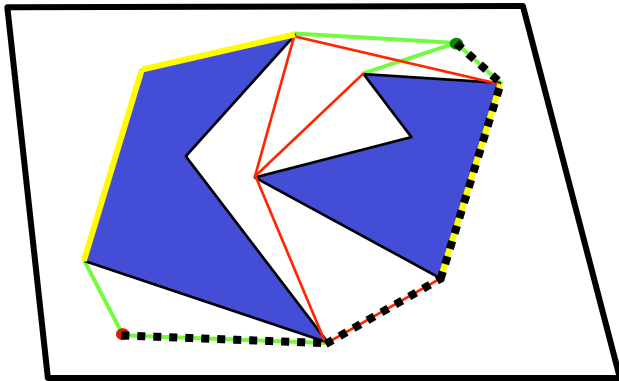

• q_{init}
• q_{goal}

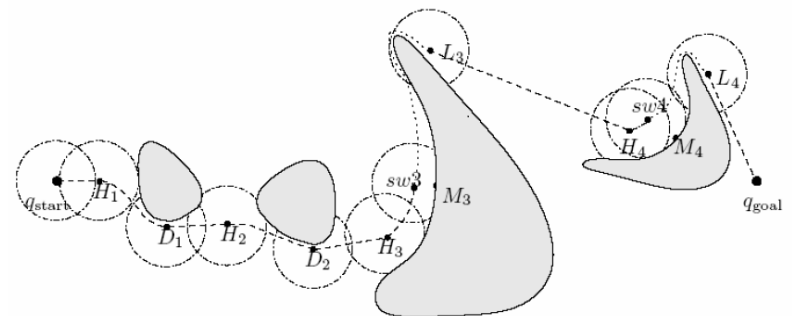
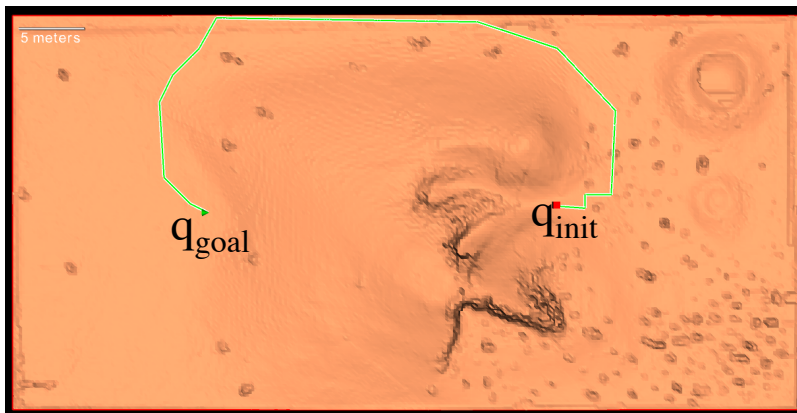

What is a Path?

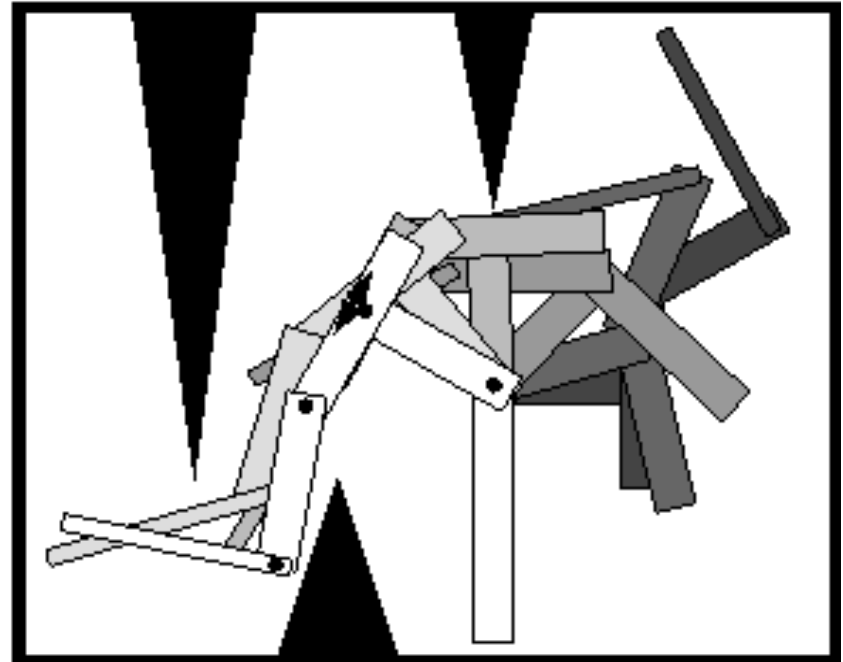
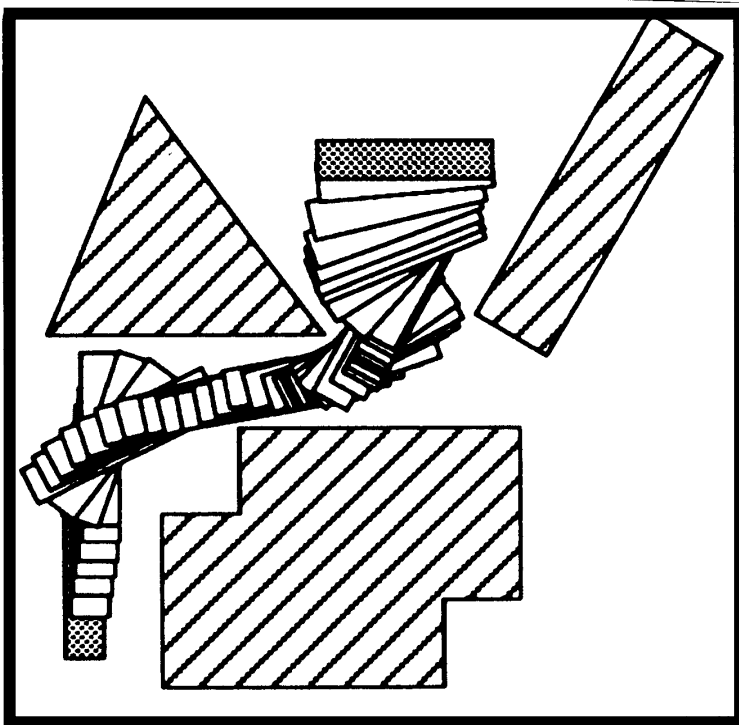

Tool: Configuration Space (C-Space C)

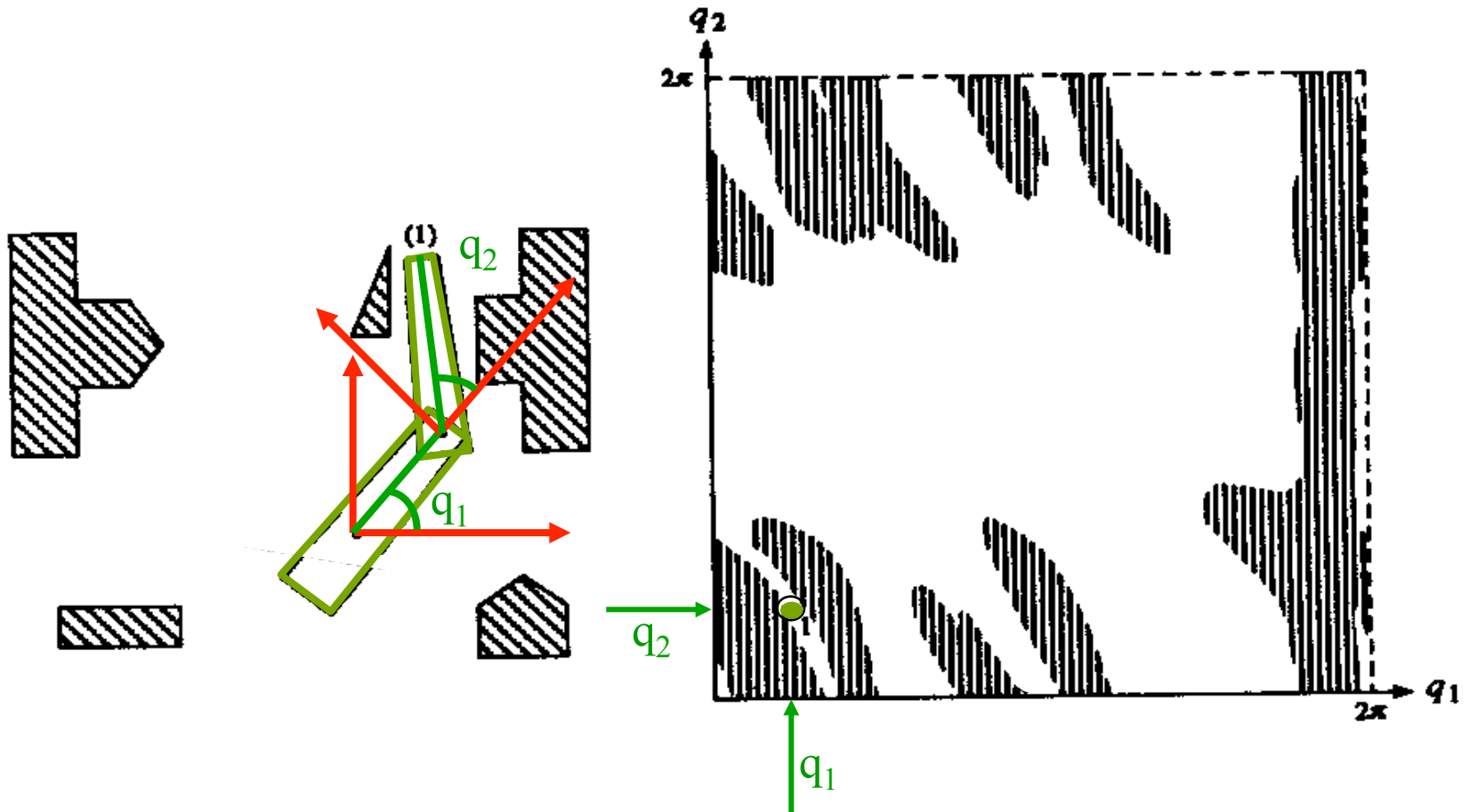

Tool: Configuration Space (C-Space C)

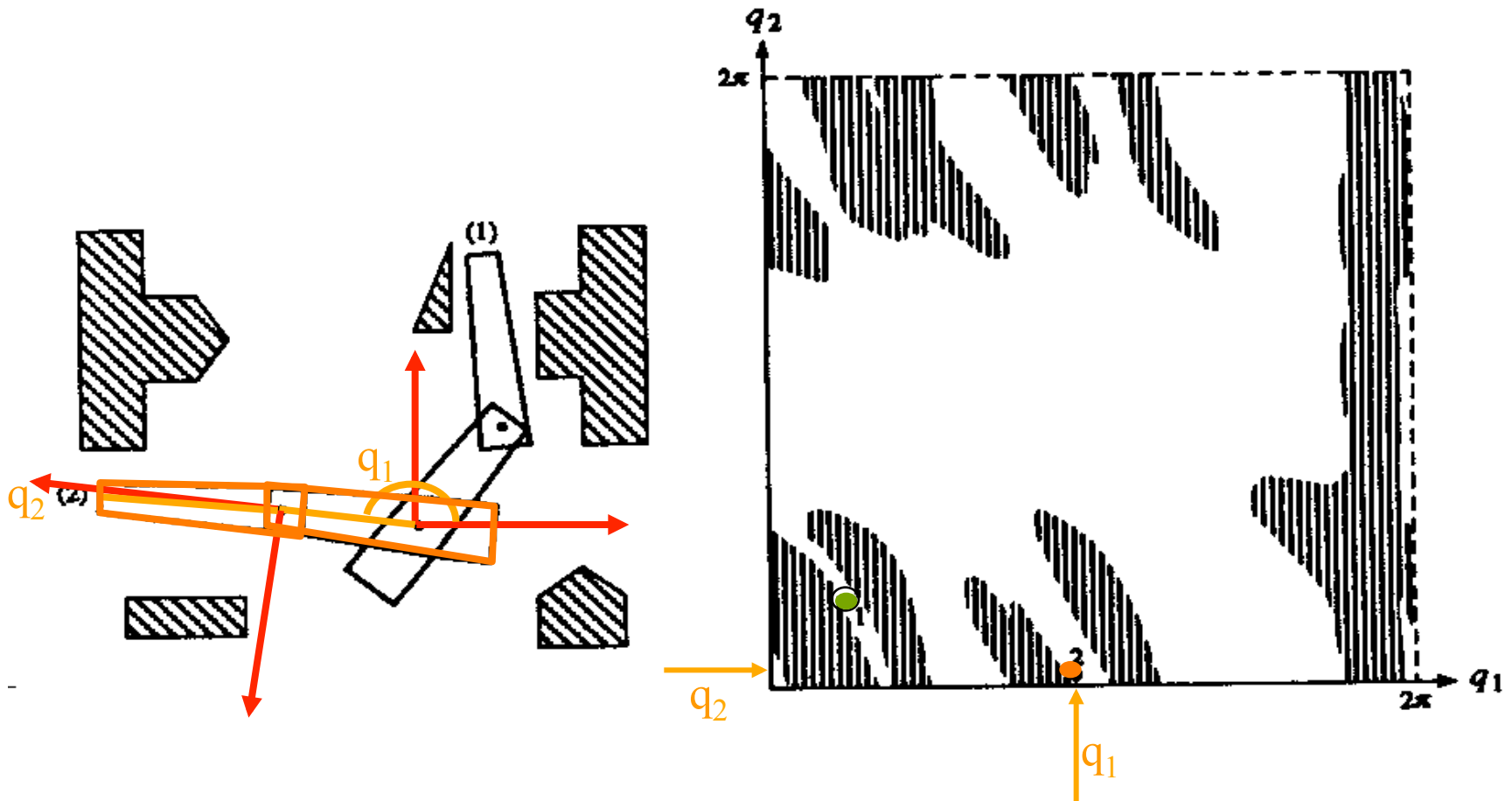

Tool: Configuration Space (C-Space C)

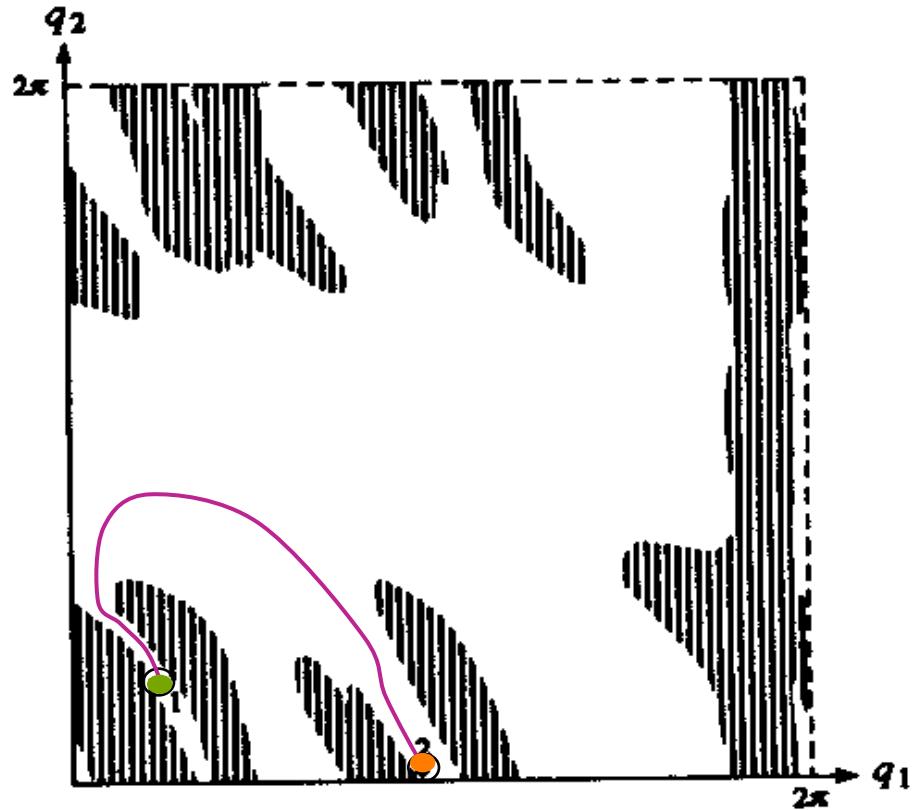
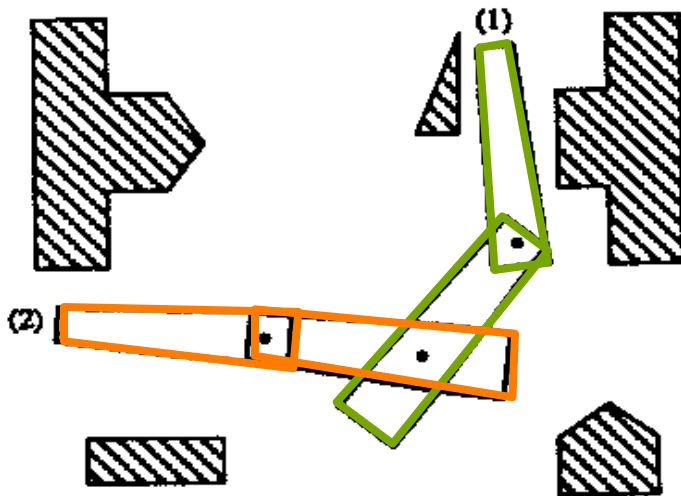

Articulated Robot Example

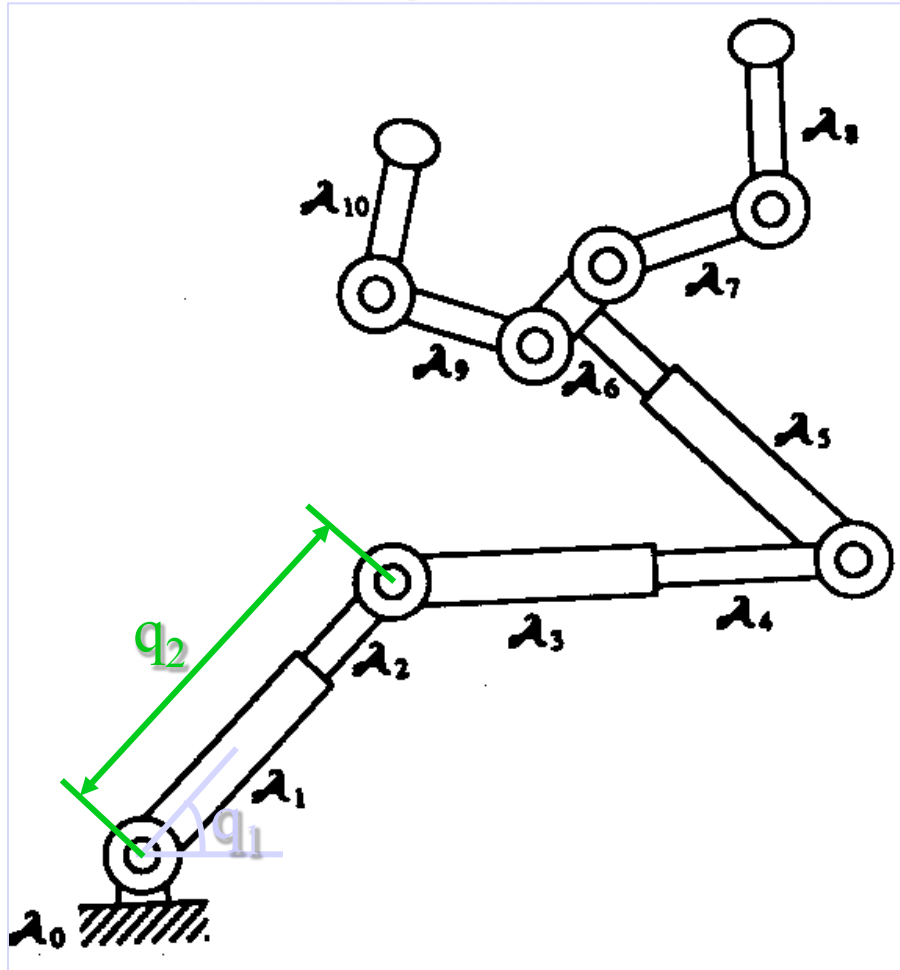

$$q = (q_1, q_2, \dots, q_{10})$$



Configuration Space of a Robot

- Space of all its possible configurations
- But the topology of this space is usually not that of a Cartesian space

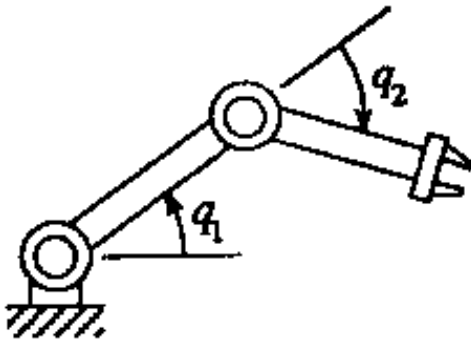

Configuration Space of a Robot

- Space of all its possible configurations
- But the topology of this space is usually not that of a Cartesian space

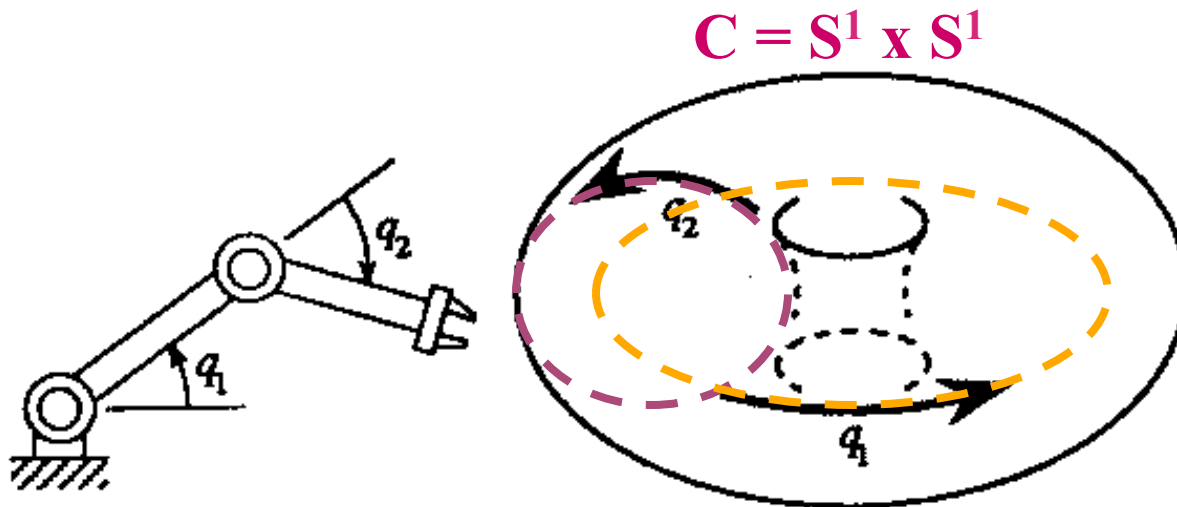

Configuration Space of a Robot

- Space of all its possible configurations
- But the topology of this space is usually not that of a Cartesian space

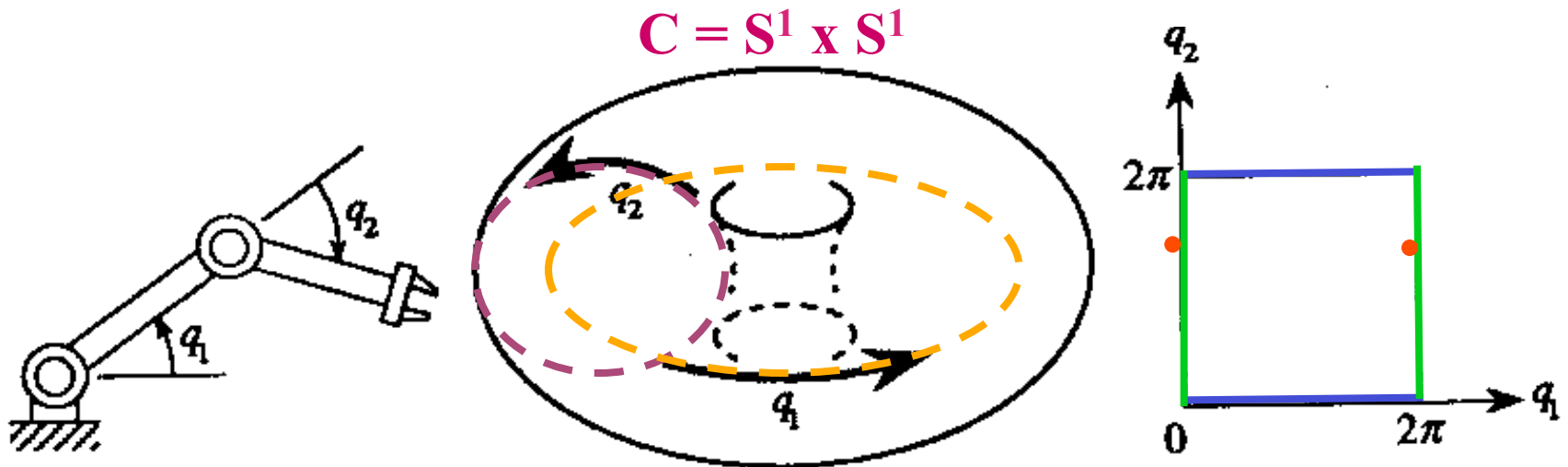

Parameterization of $SO(3)$

- Euler angles: (ϕ, θ, ψ)

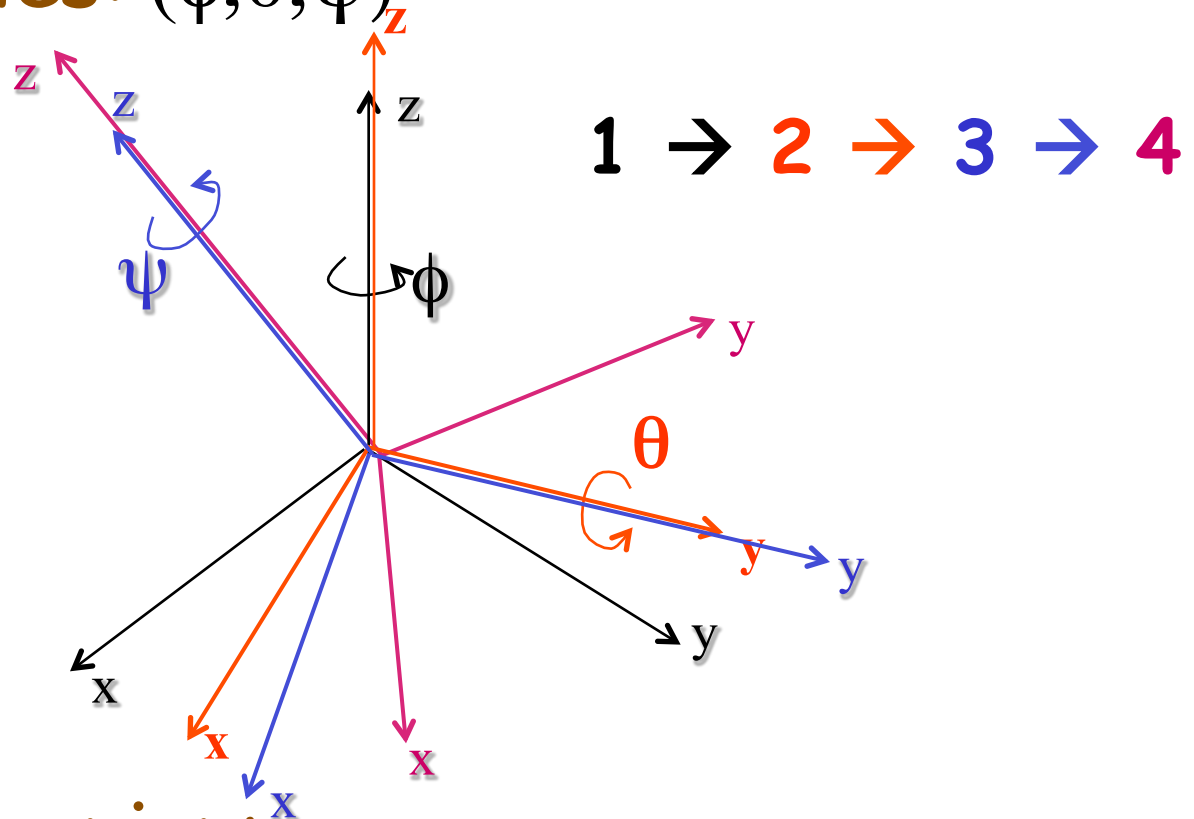

- Unit quaternion:

$$(\cos \theta/2, n_1 \sin \theta/2, n_2 \sin \theta/2, n_3 \sin \theta/2)$$



A welding robot

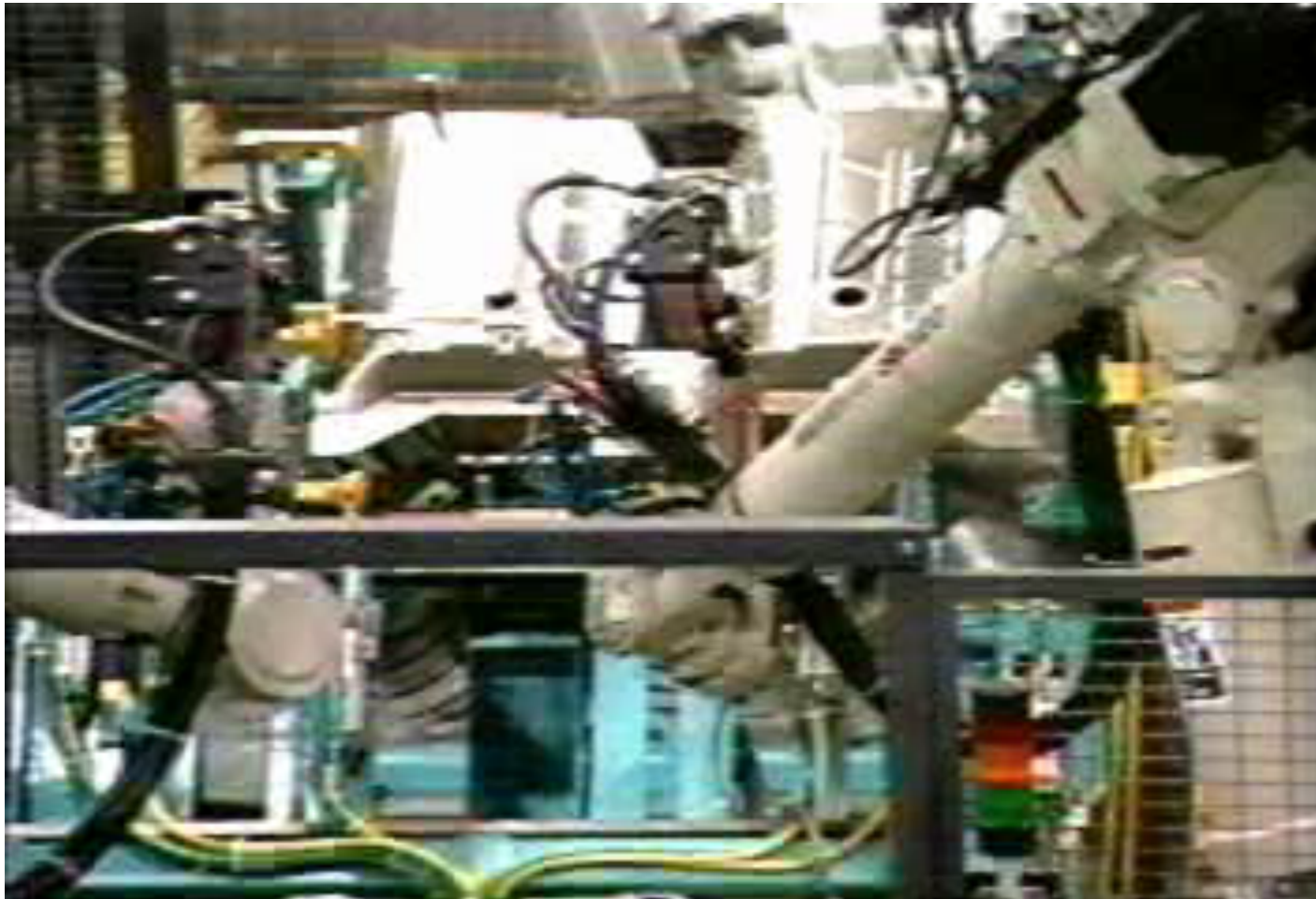

CSCE-574 Robotics



A Stuart Platform

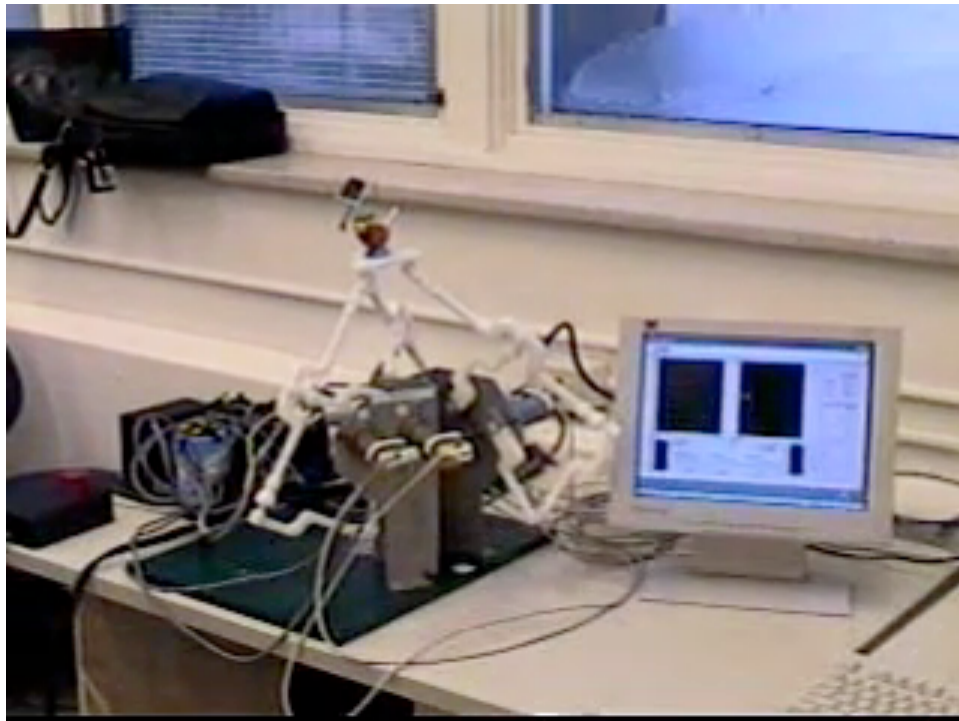

Barrett WAM arm on a mobile platform



Configuration Space Obstacle

How do we get from **A** to **B** ?

Reference *configuration*

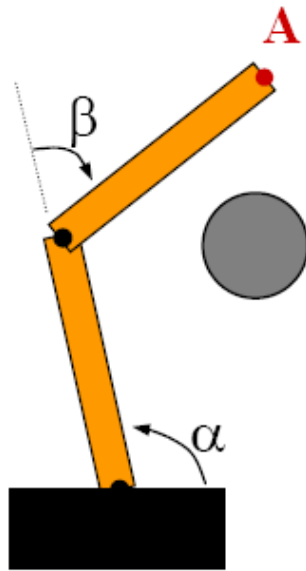

B

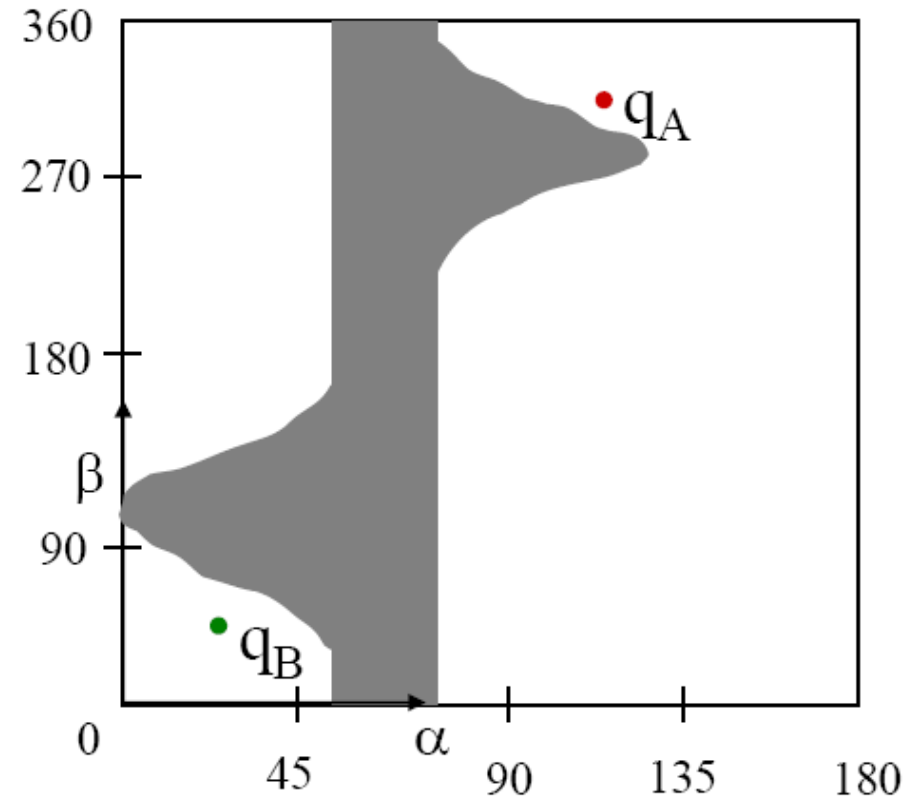

An obstacle in the robot's workspace

The C-space representation
of this obstacle...

Two link path

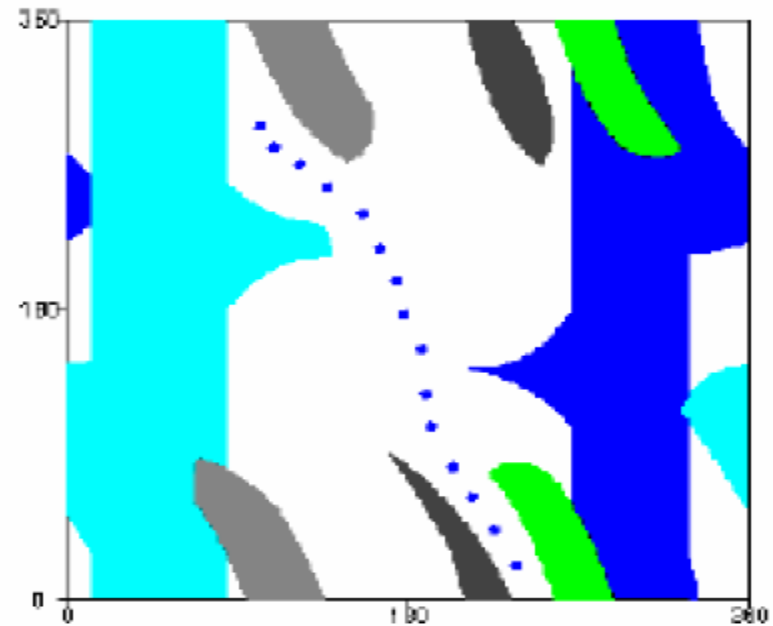
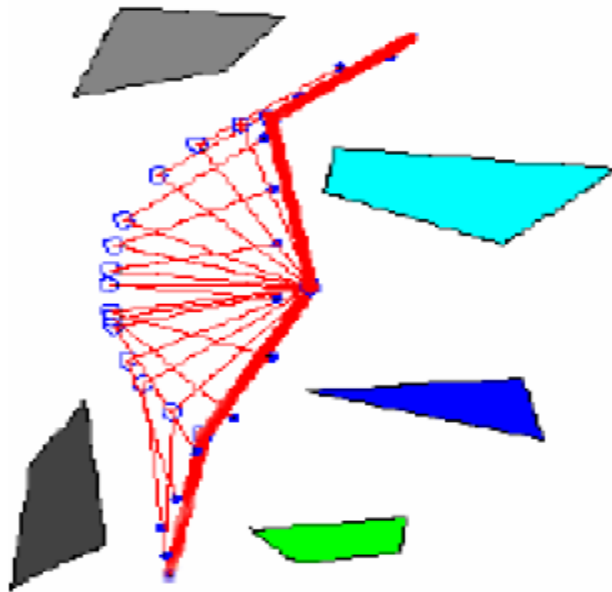

Thanks to Ken Goldberg



2D Rigid Object

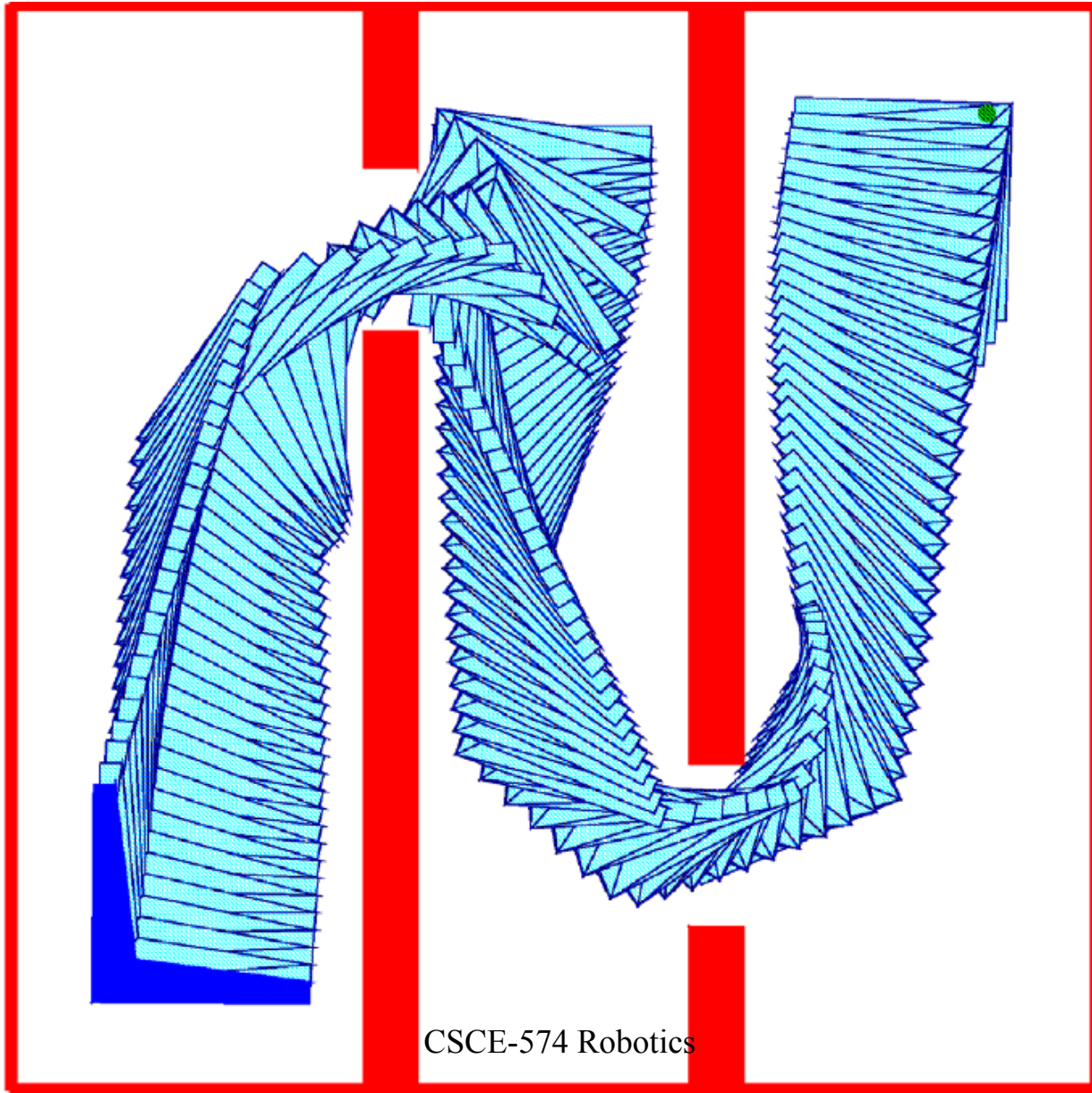

CSCE-574 Robotics



The Configuration Space

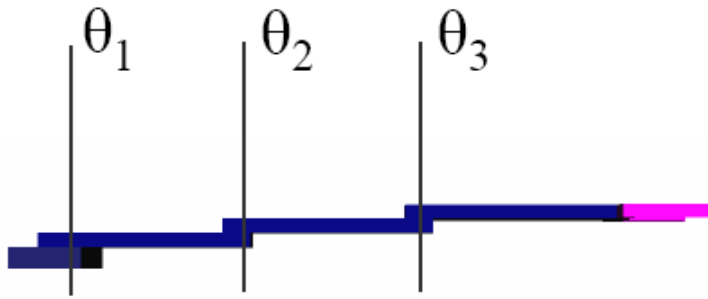

TOP
VIEW



workspace

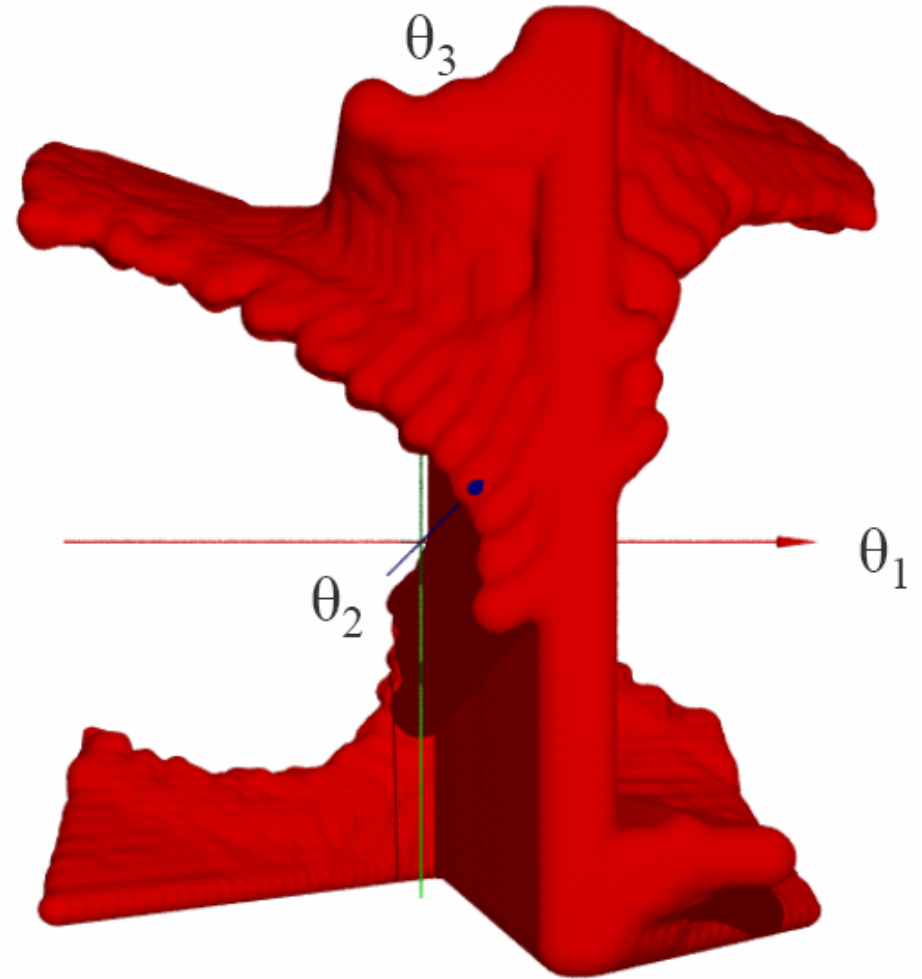

C-space

Moving a piano

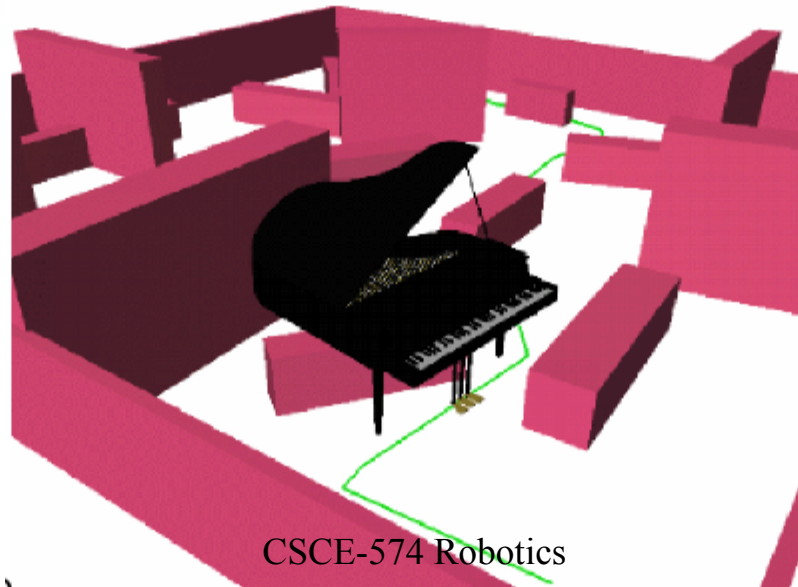
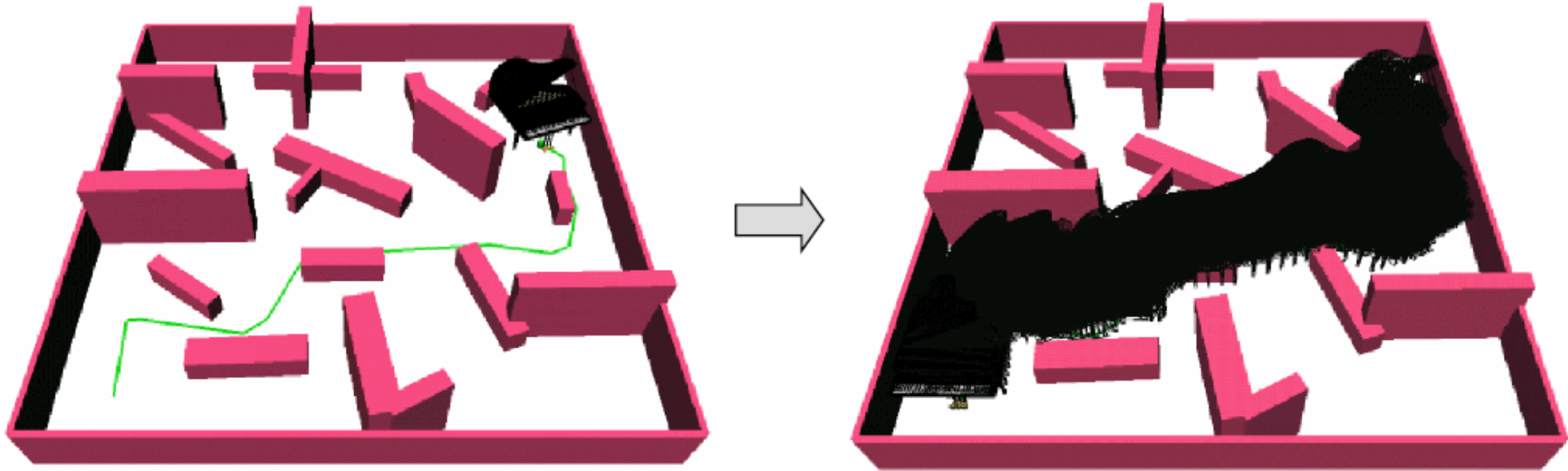

Parameterization of Torus

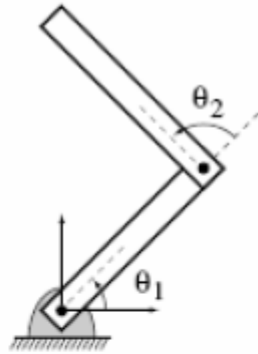

(a)

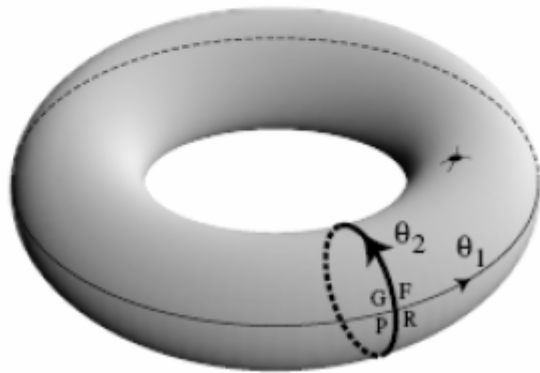

(b)

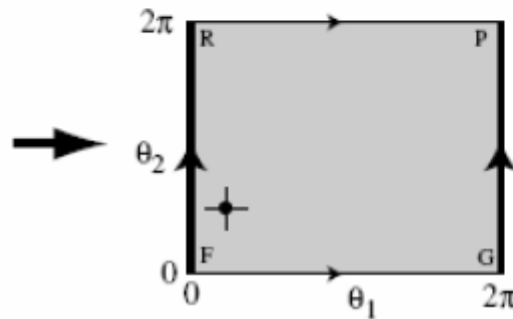

(c)

$$(\theta_1, \theta_2) \in \mathbb{R}^2,$$

problems at $\theta_i = \{0, 2\pi\}$.



Linear-Time Computation of C-Obstacle in 2-D

(convex polygons)

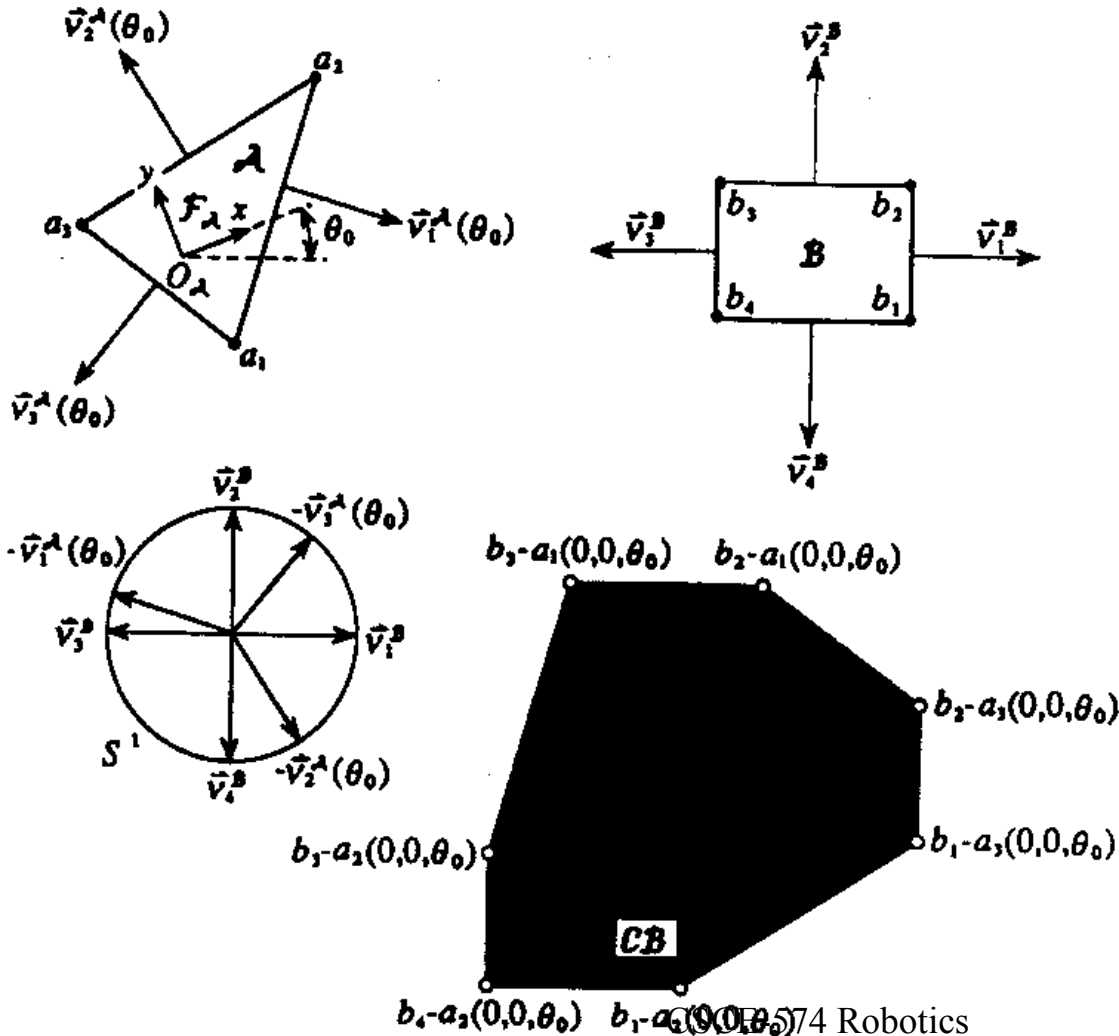

Rigid Robot Translating and Rotating in 2-D

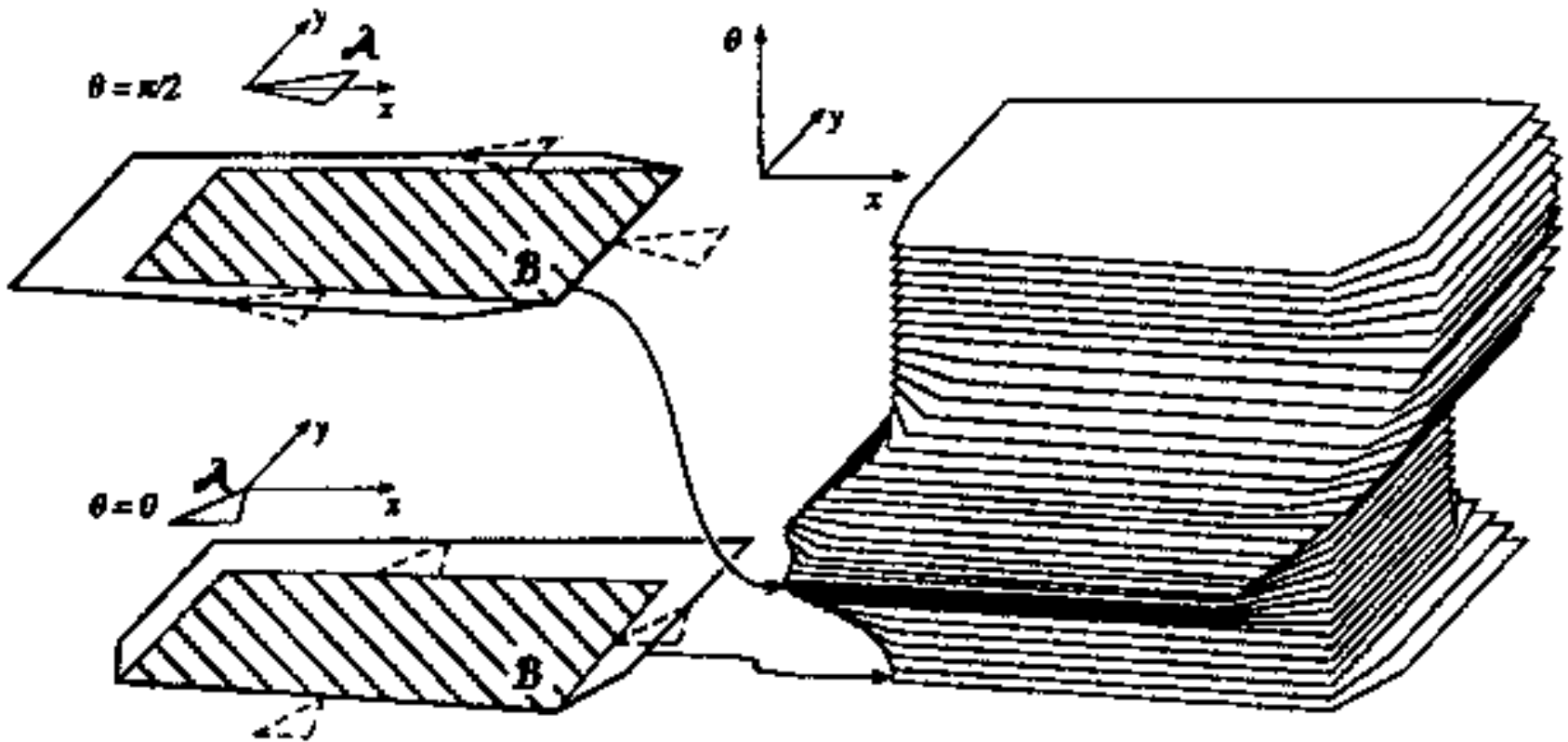

Free and Semi-Free Paths

- A **free path** lies entirely in the free space F
- A **semi-free path** lies entirely in the semi-free space



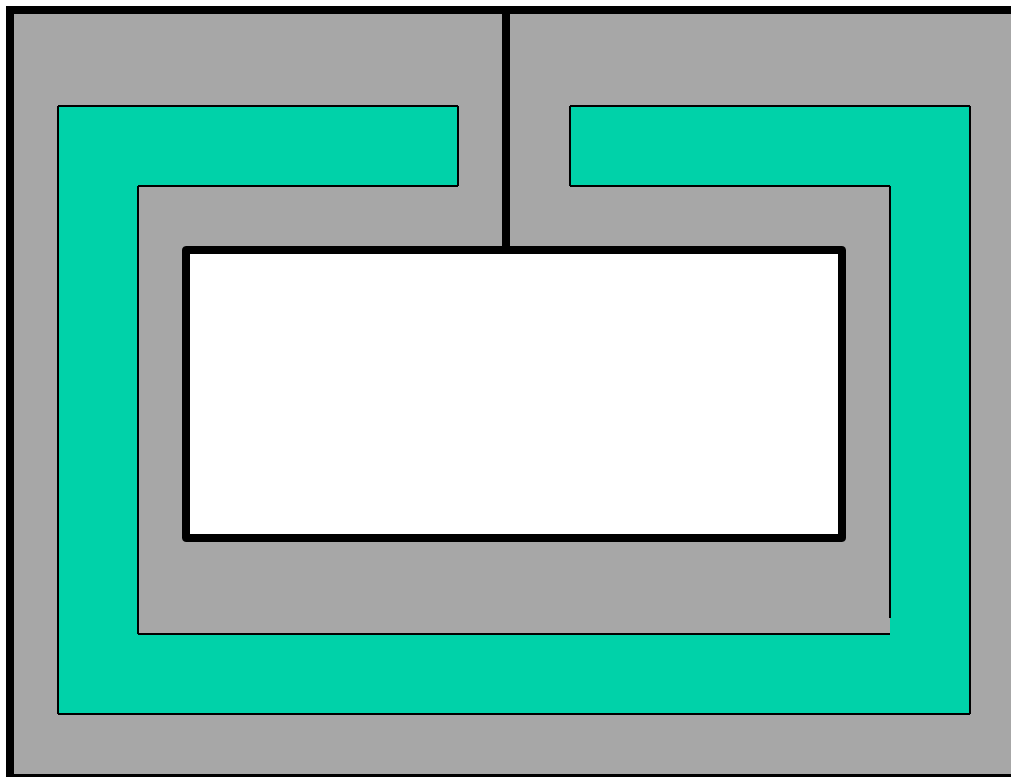
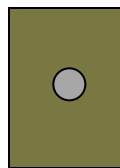

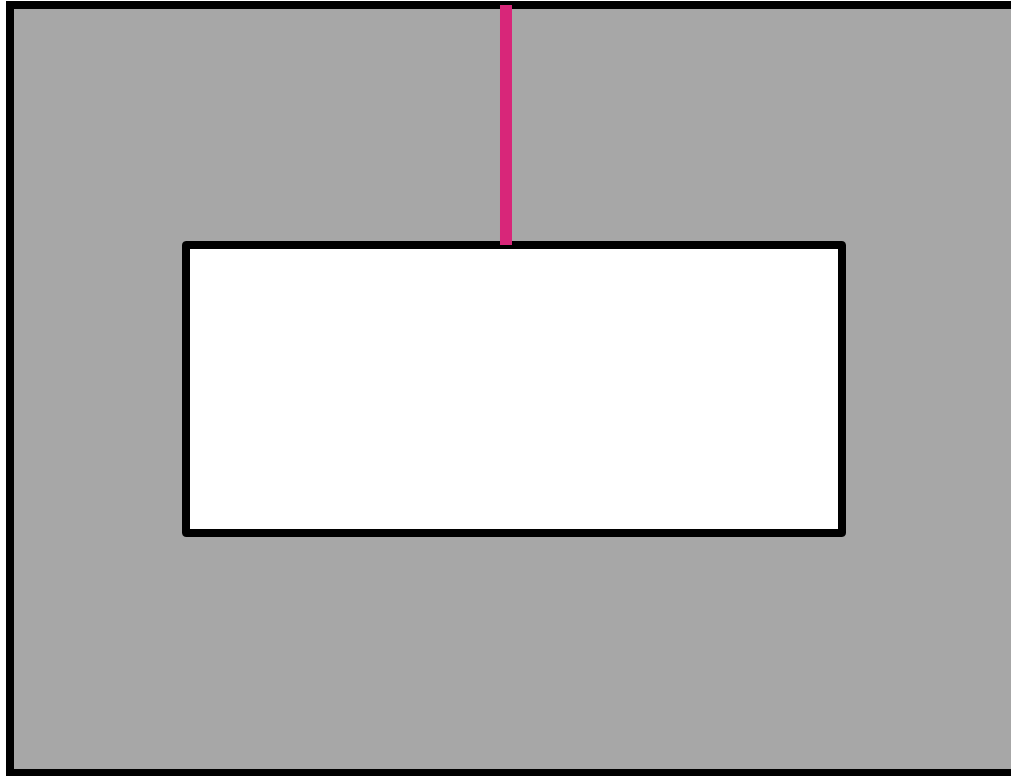

Notion of Homotopic Paths

- Two paths with the same endpoints are **homotopic** if one can be continuously deformed into the other

- $\mathbb{R} \times S^1$ example:

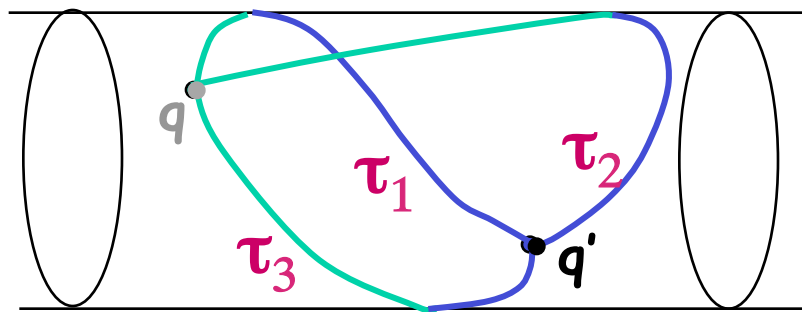

- τ_1 and τ_2 are homotopic
- τ_1 and τ_3 are not homotopic
- In this example, infinity of **homotopy classes**



Connectedness of C-Space

- C is **connected** if every two configurations can be connected by a path
- C is **simply-connected** if any two paths connecting the same endpoints are homotopic
Examples: \mathbf{R}^2 or \mathbf{R}^3
- Otherwise C is **multiply-connected**
Examples: S^1 and $SO(3)$ are multiply- connected:
 - In S^1 , infinity of homotopy classes
 - In $SO(3)$, only two homotopy classes



Classes of Homotopic Free Paths

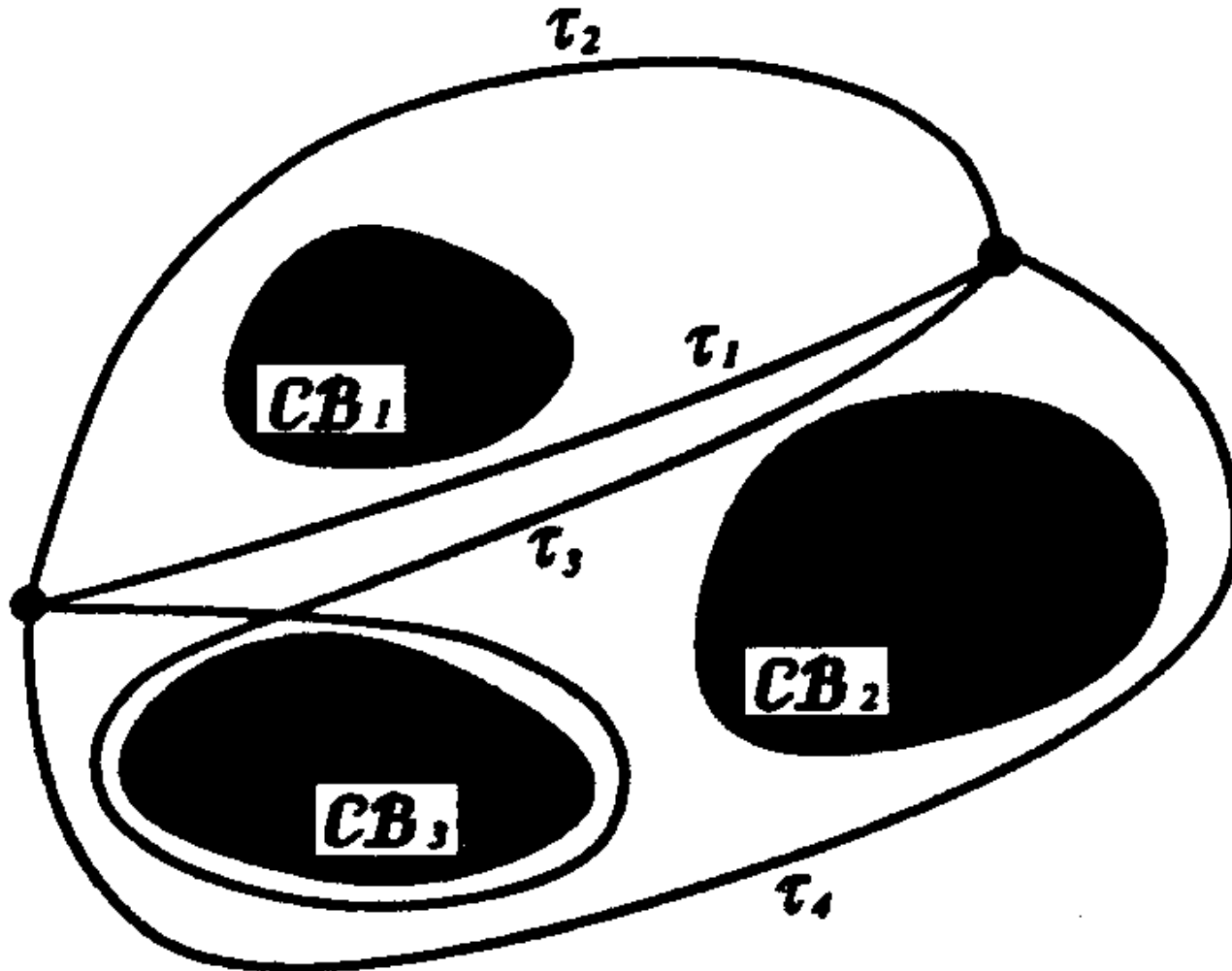

Probabilistic Roadmaps PRMs

The basic idea behind PRM is to take random samples from the configuration space of the robot, testing them for whether they are in the free space, and use a local planner to attempt to connect these configurations to other nearby configurations. The starting and goal configurations are added in, and a graph search algorithm is applied to the resulting graph to determine a path between the starting and goal configurations.

Kavraki, L. E.; Svestka, P.; Latombe, J.-C.; Overmars, M. H. (1996), "Probabilistic roadmaps for path planning in high-dimensional configuration spaces", *IEEE Transactions on Robotics and Automation* 12 (4): 566–580.



Rapidly-exploring Random Trees

- A point P in C is randomly chosen.
- The nearest vertex in the RRT is selected.
- A new edge is added from this vertex in the direction of P , at distance ϵ .
- The further the algorithm goes, the more space is covered.



Rapidly-expanding Random Trees

- Starting vertex



Rapidly-expanding Random Trees



Vertex randomly drawn



Rapidly-expanding Random Trees



Nearest vertex



Rapidly-expanding Random Trees

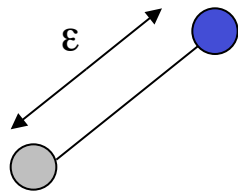

New vertex

The vertex is in C_{free}



Rapidly-expanding Random Trees

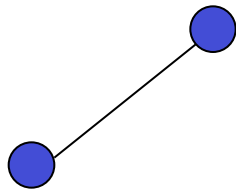

Vertex randomly drawn



Rapidly-expanding Random Trees



Rapidly-expanding Random Trees

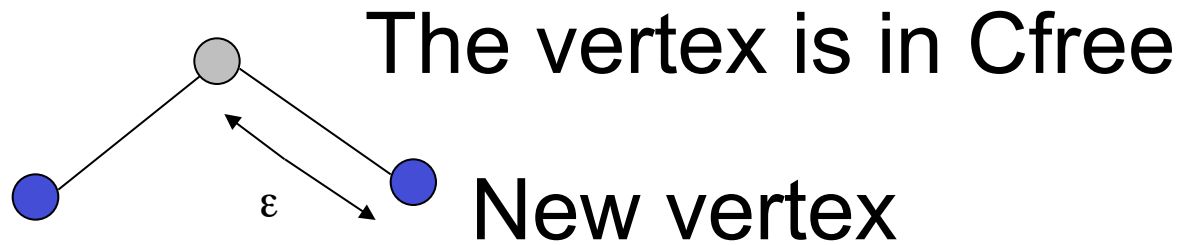

Rapidly-expanding Random Trees

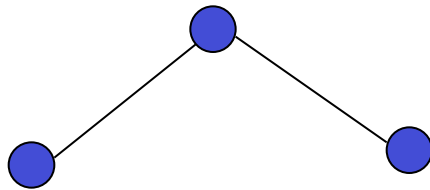

Rapidly-expanding Random Trees

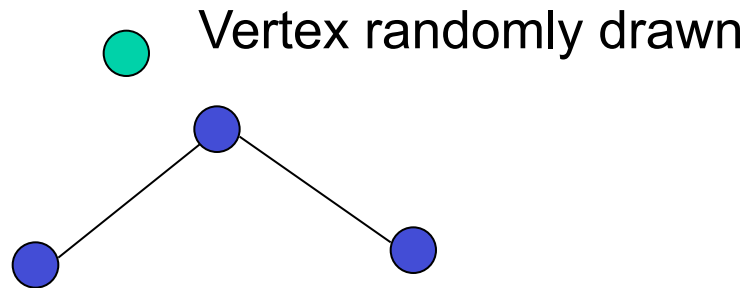

Rapidly-expanding Random Trees

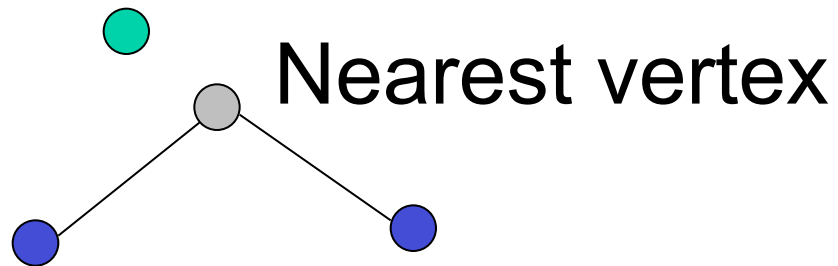

Rapidly-expanding Random Trees

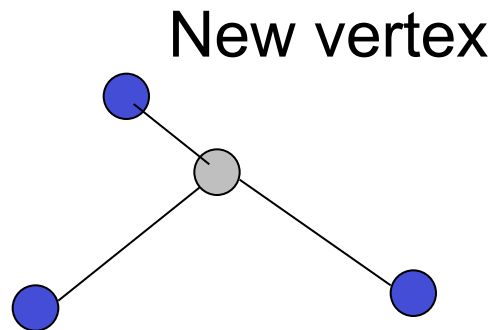

Rapidly-expanding Random Trees

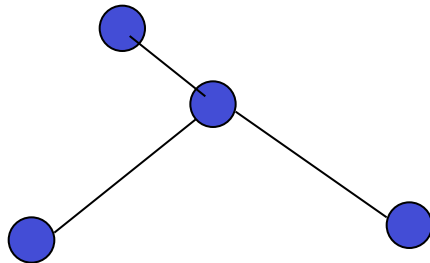

And it continues...



RRT-Connect

- We grow two trees, one from the beginning vertex and another from the end vertex
- Each time we create a new vertex, we try to greedily connect the two trees



RRT-Connect: example

- Start



- Goal



RRT-Connect: example



Random vertex



RRT-Connect: example

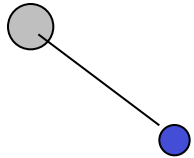

RRT-Connect: example

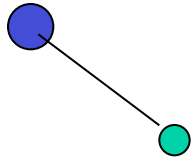

We greedily connect the
bottom tree to our new
vertex



RRT-Connect: example

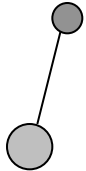
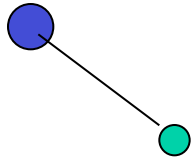

RRT-Connect: example

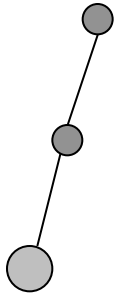
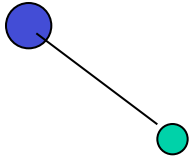

RRT-Connect: example

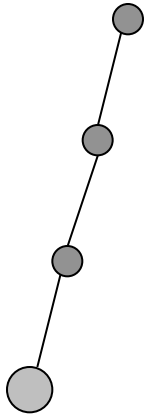
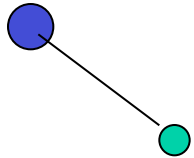

RRT-Connect: example

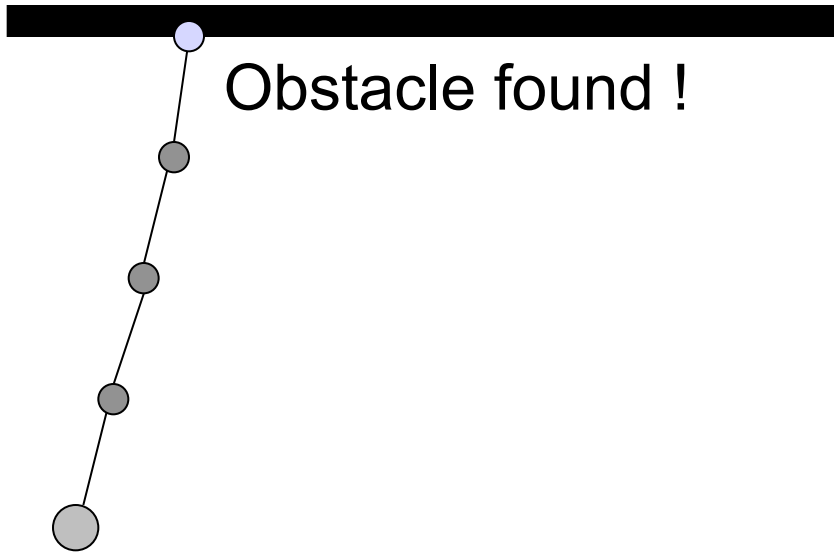
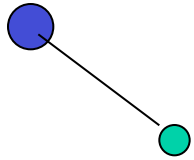

RRT-Connect: example

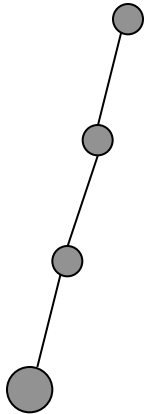
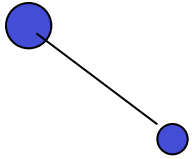

Now we swap roles !



RRT-Connect: example

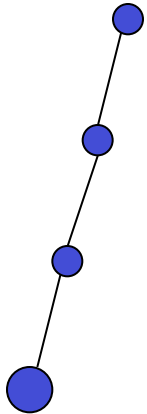
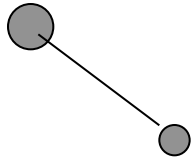

Now we swap roles !



RRT-Connect: example

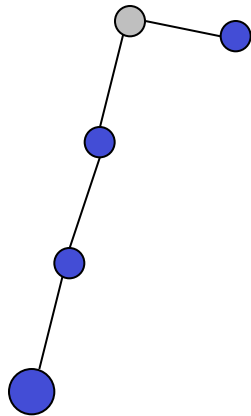
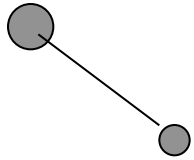

We grow the bottom tree



RRT-Connect: example

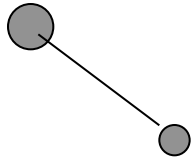

Now we greedily try to connect

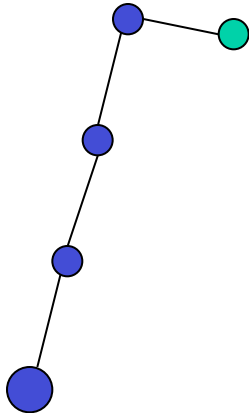

And we continue...



RRT-Connect: example

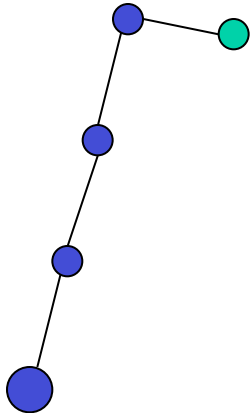
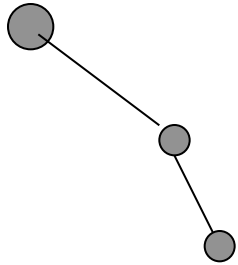

RRT-Connect: example

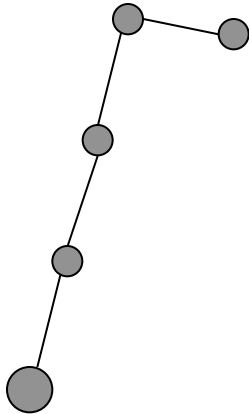
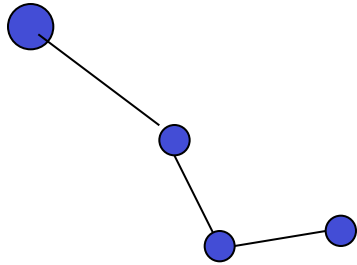

RRT-Connect: example

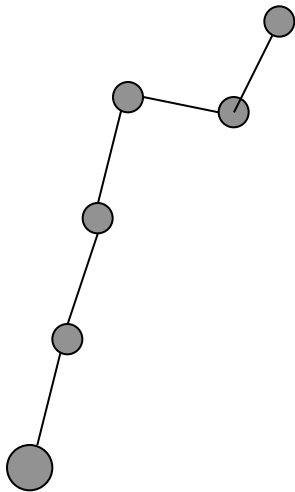
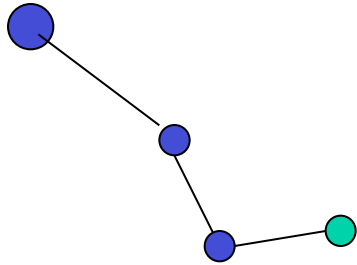

RRT-Connect: example

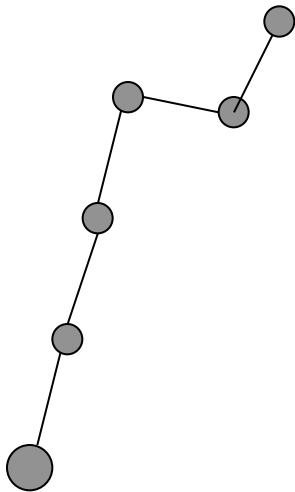
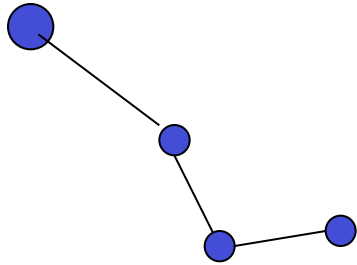

RRT-Connect: example

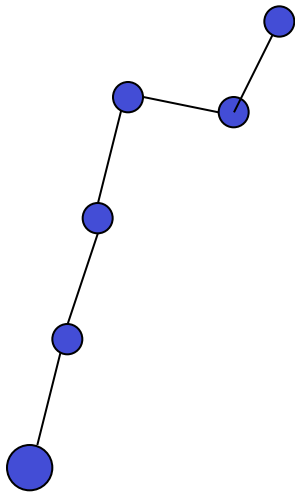
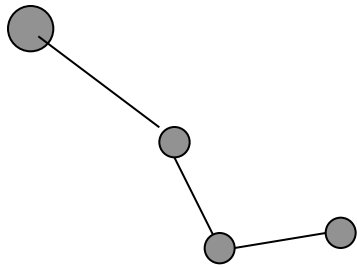

RRT-Connect: example

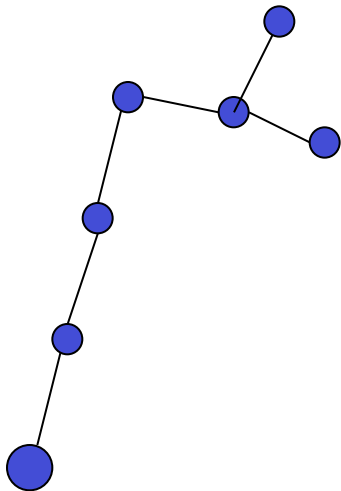
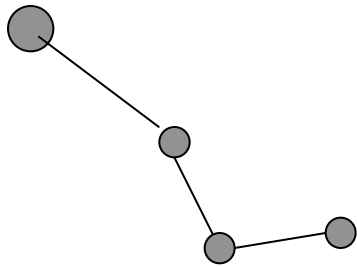

RRT-Connect: example

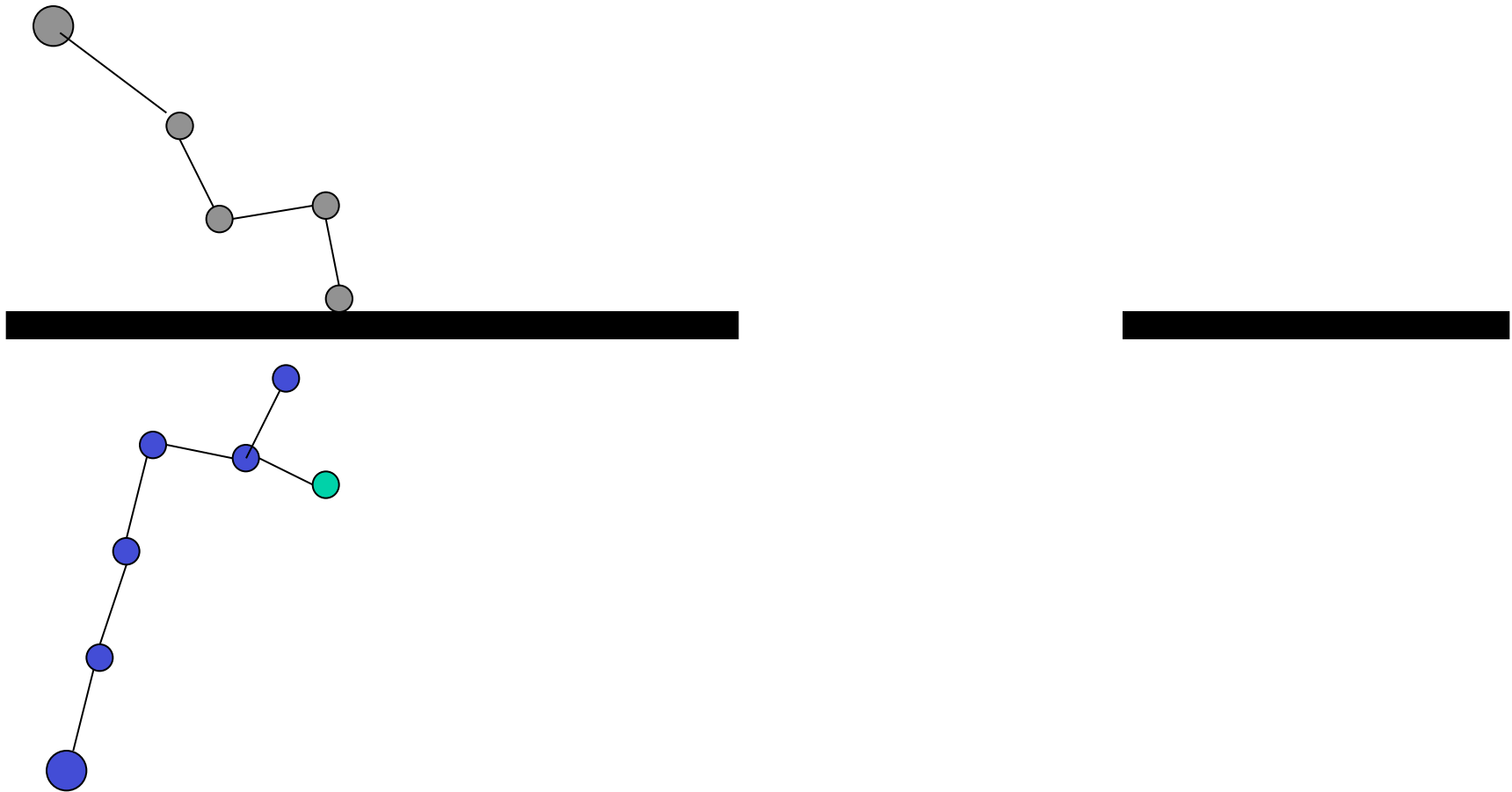

RRT-Connect: example

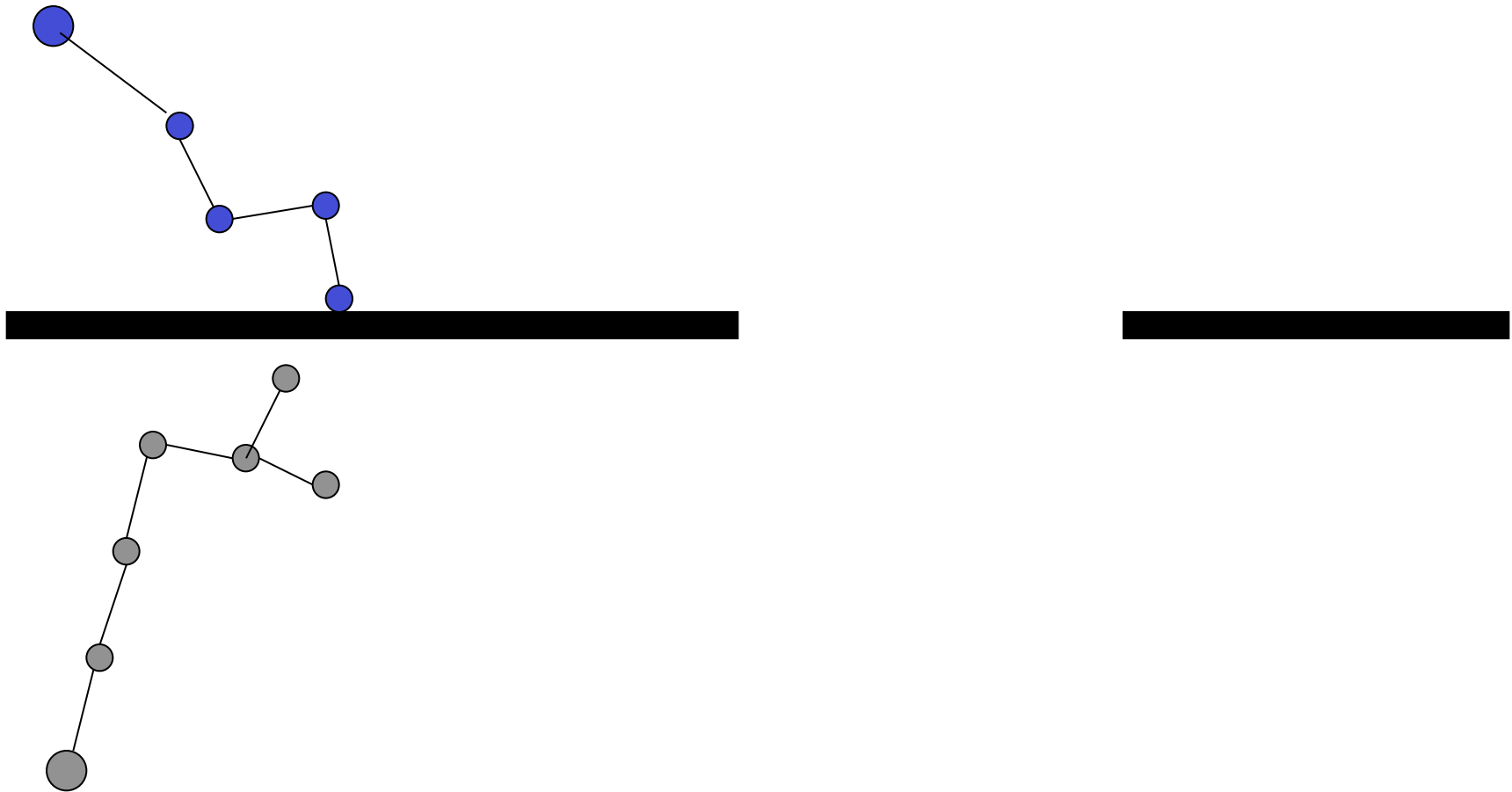

RRT-Connect: example

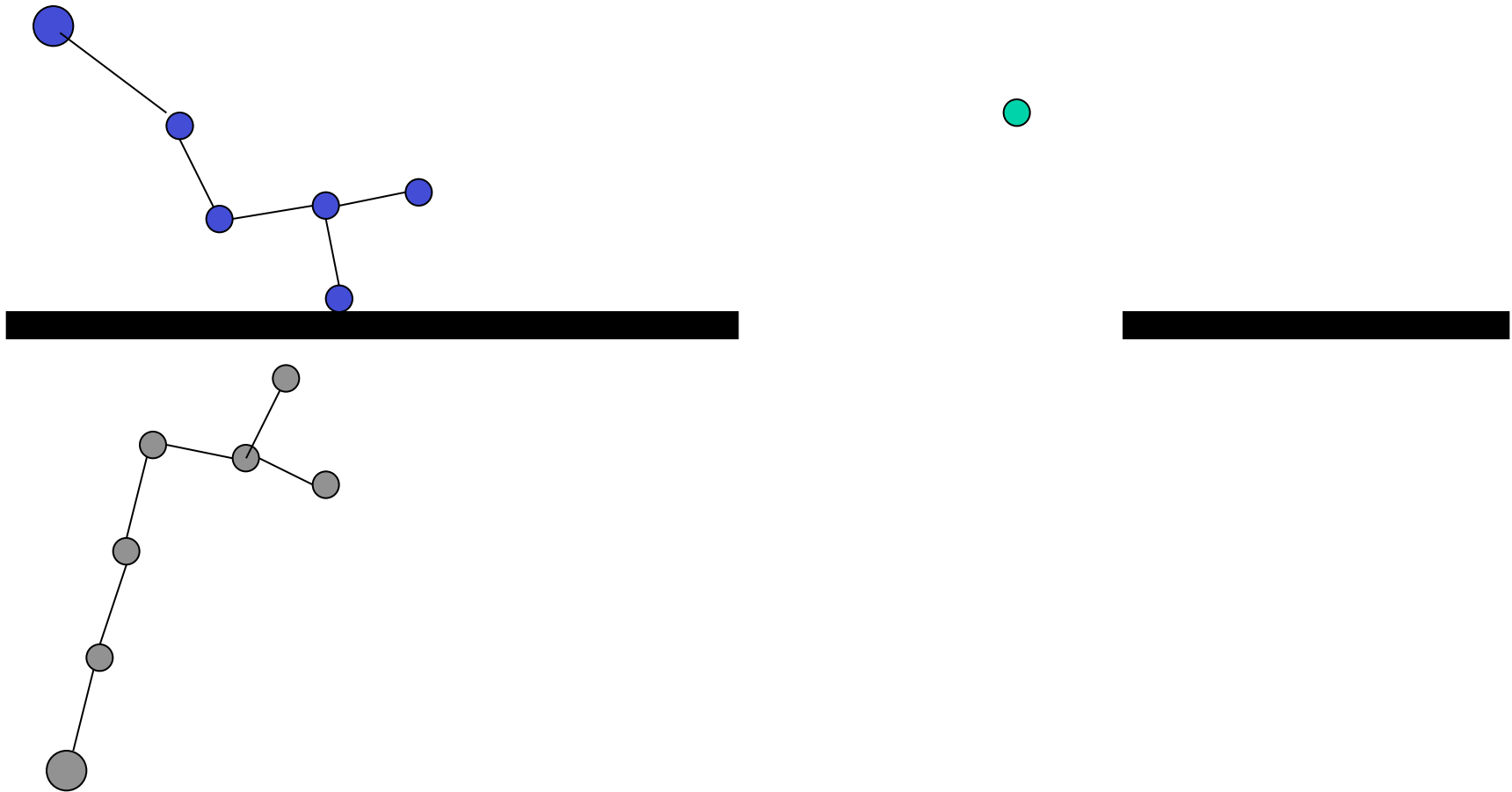

RRT-Connect: example

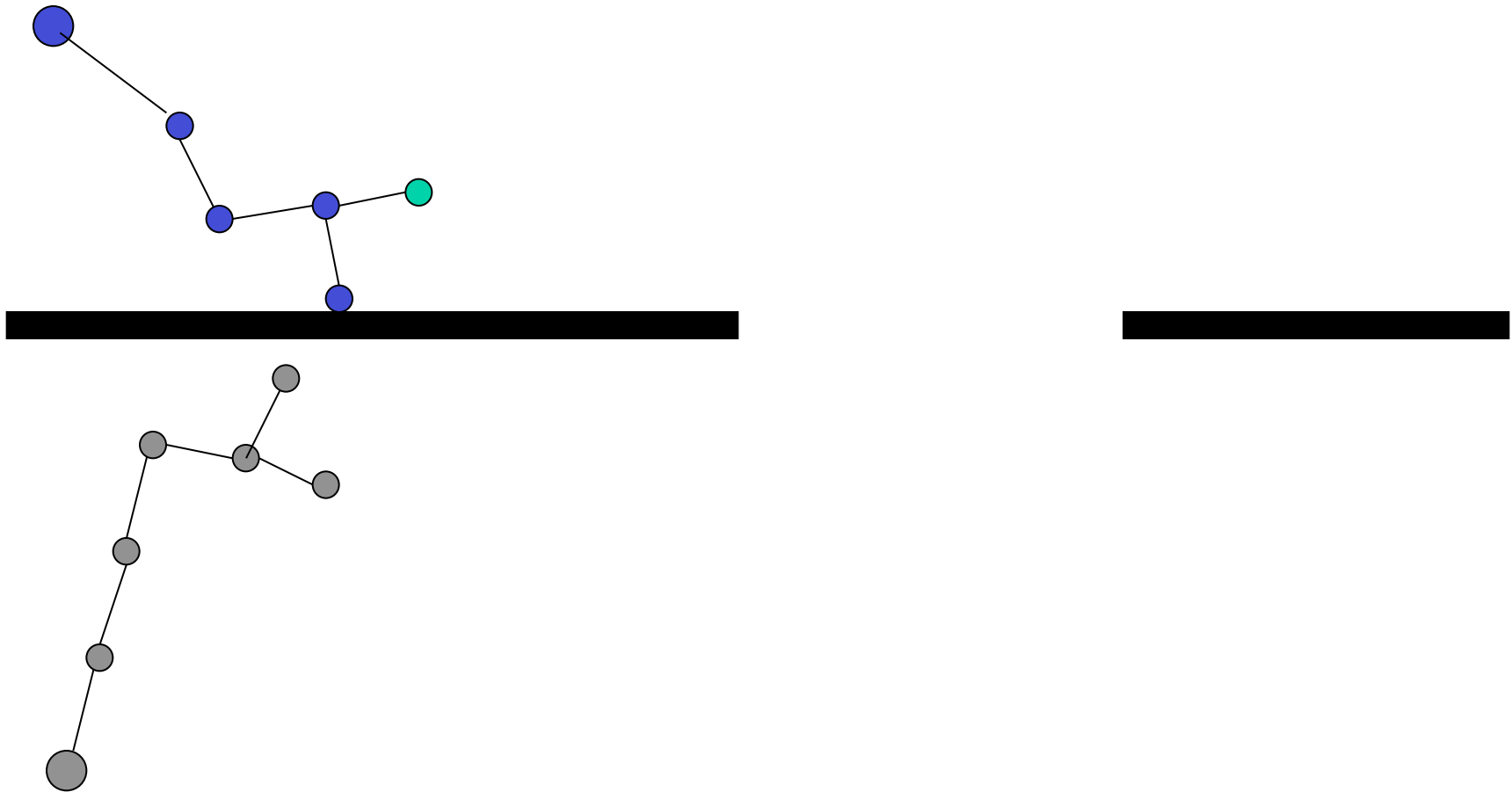

RRT-Connect: example

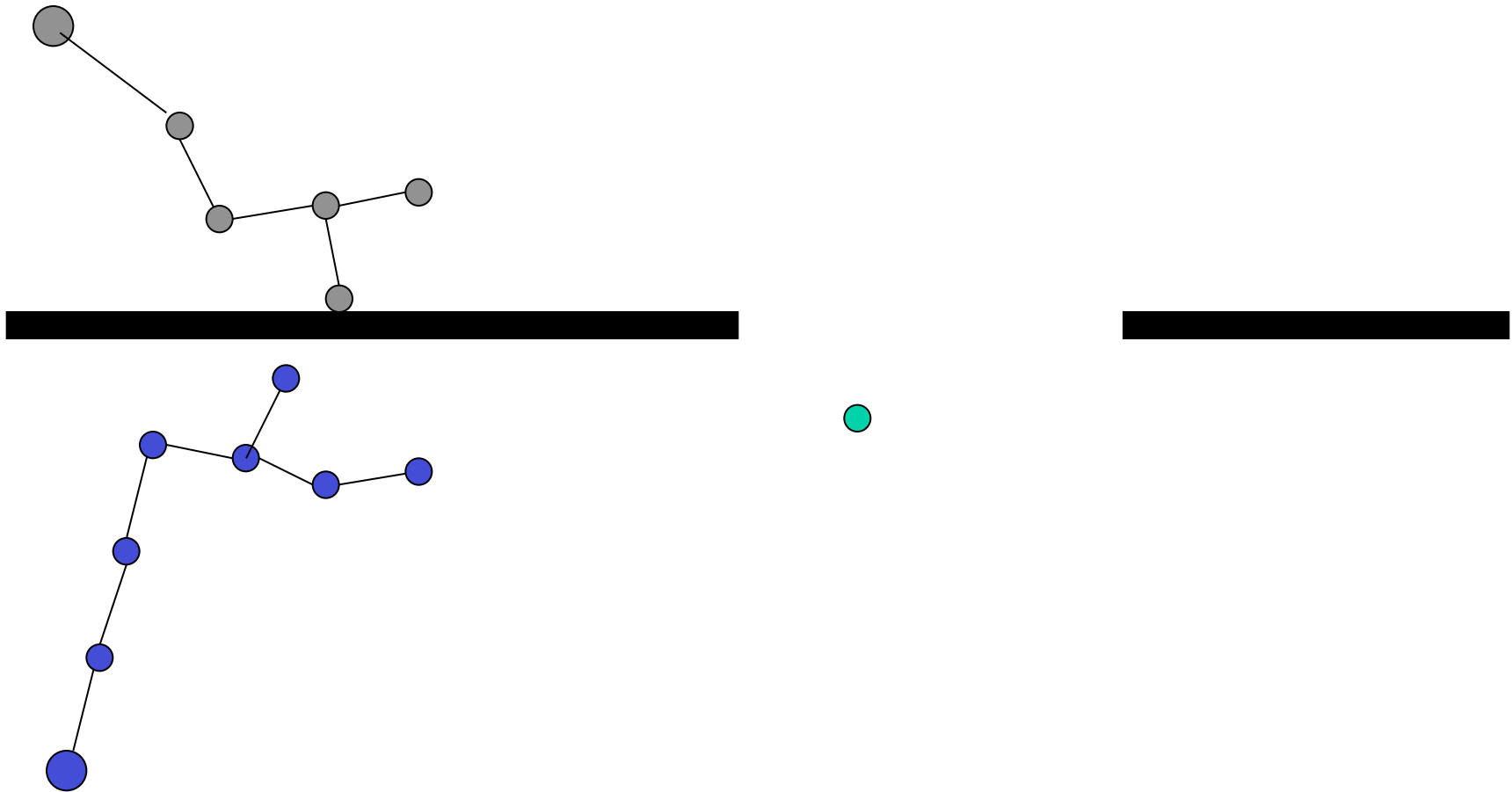

RRT-Connect: example

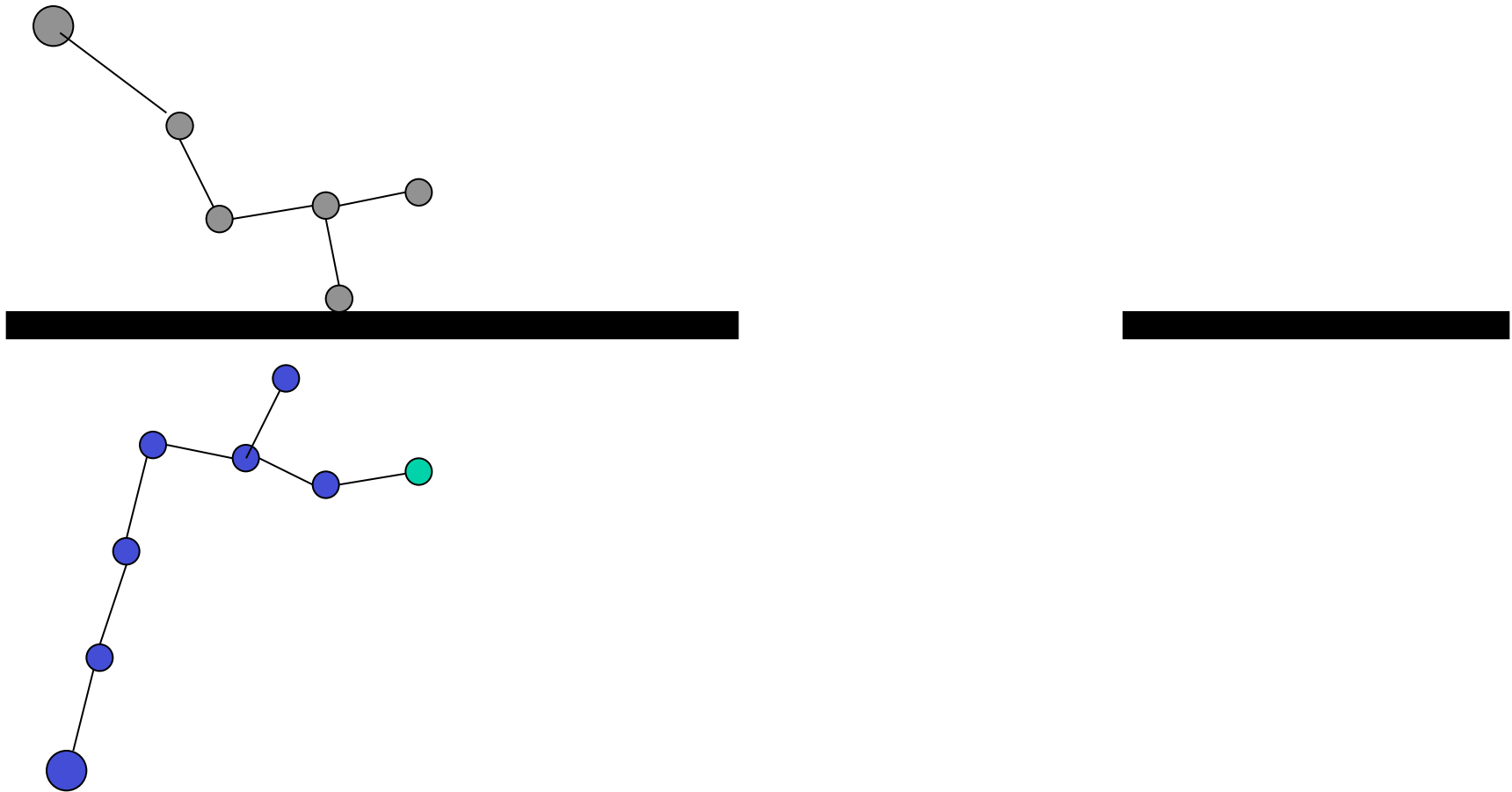

RRT-Connect: example

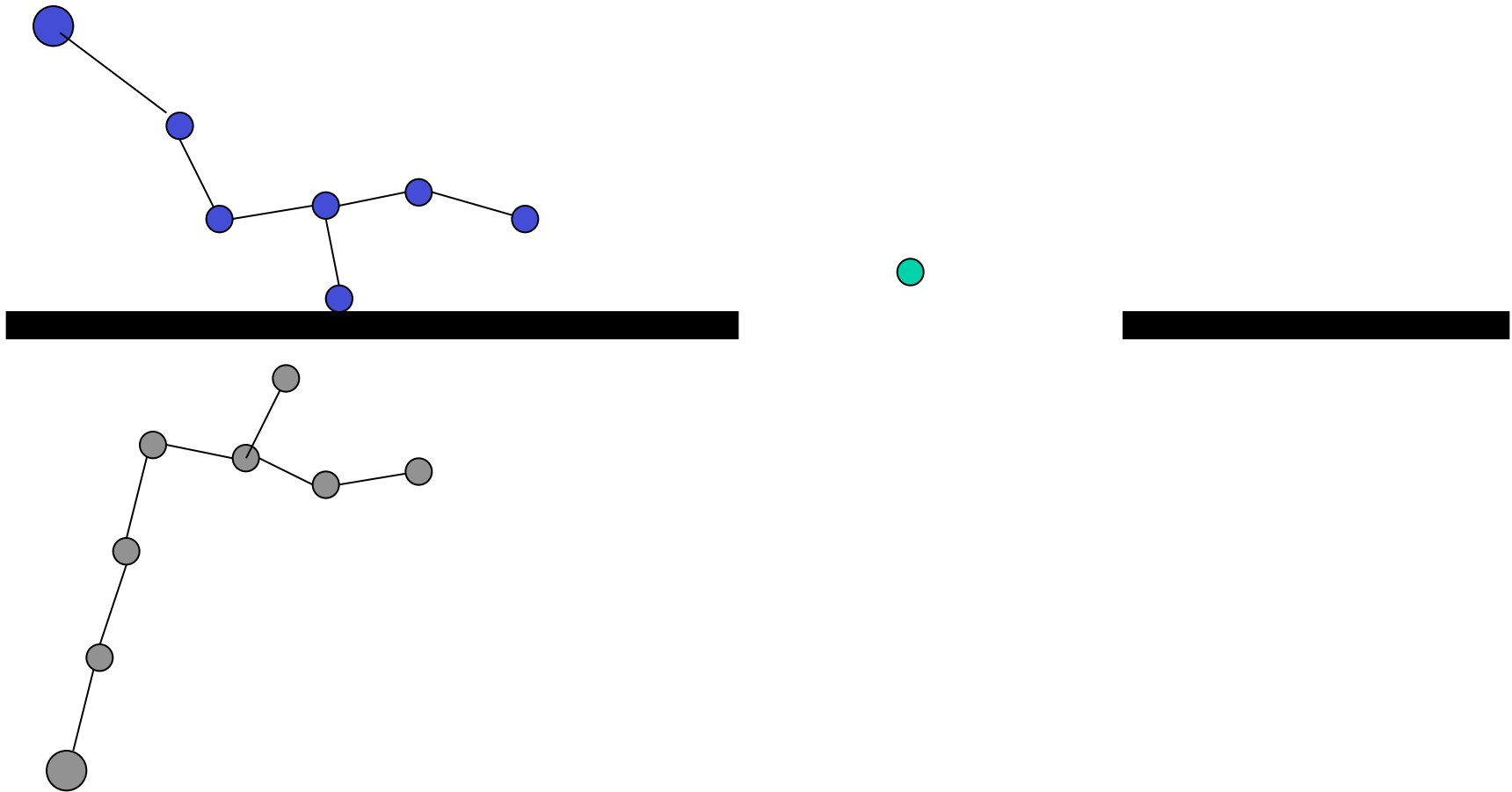

RRT-Connect: example

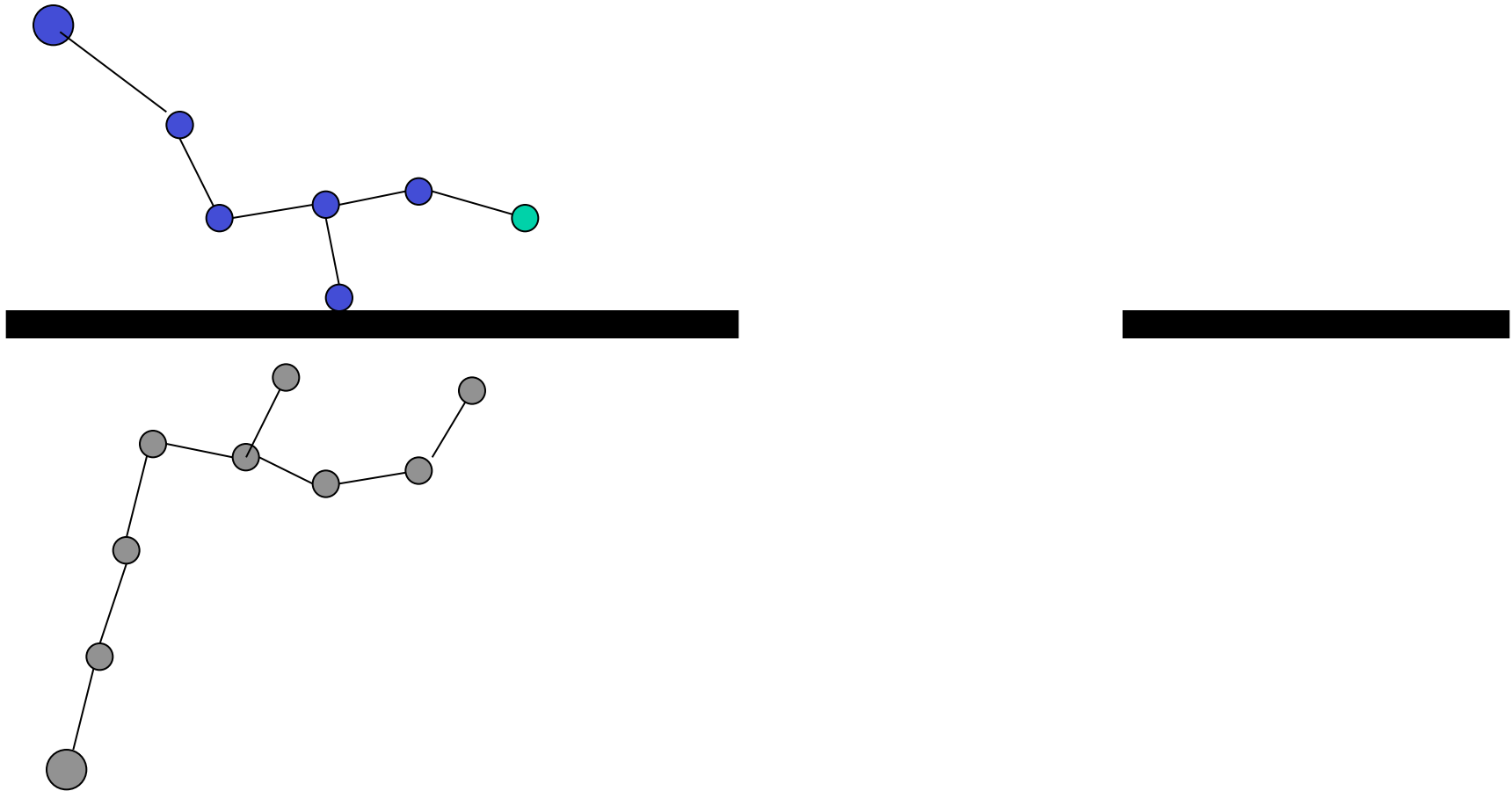

RRT-Connect: example

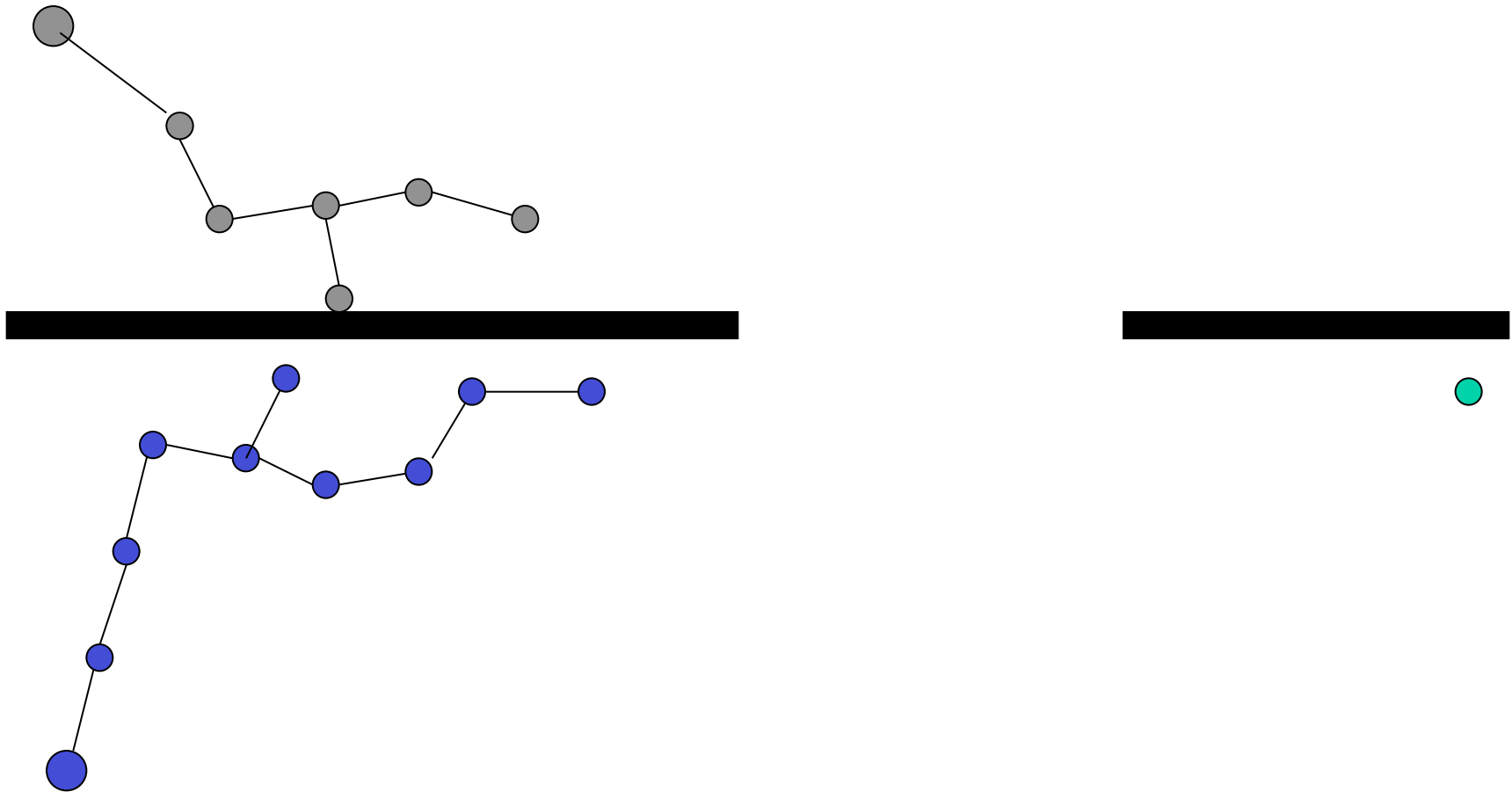

RRT-Connect: example

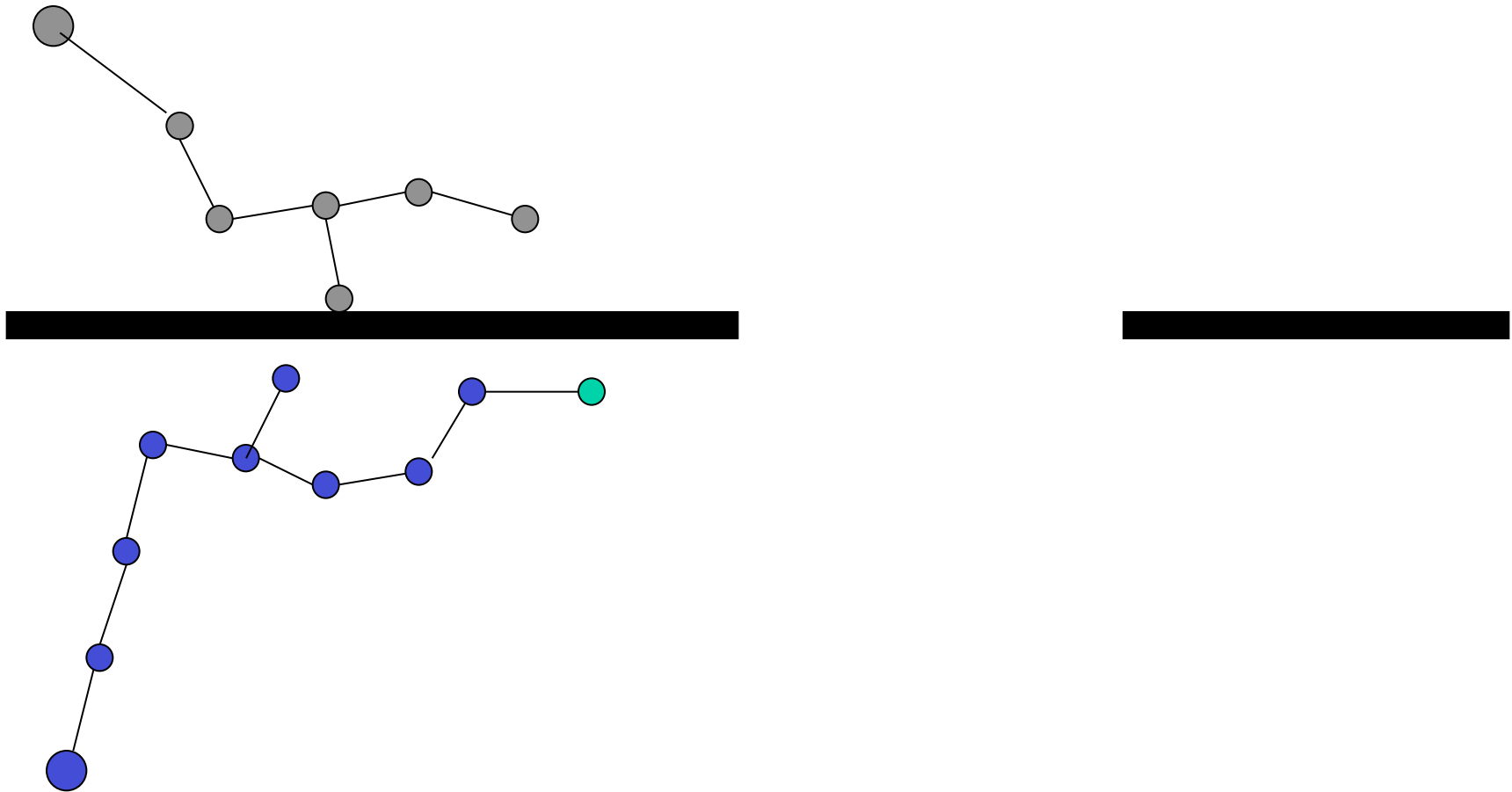

RRT-Connect: example

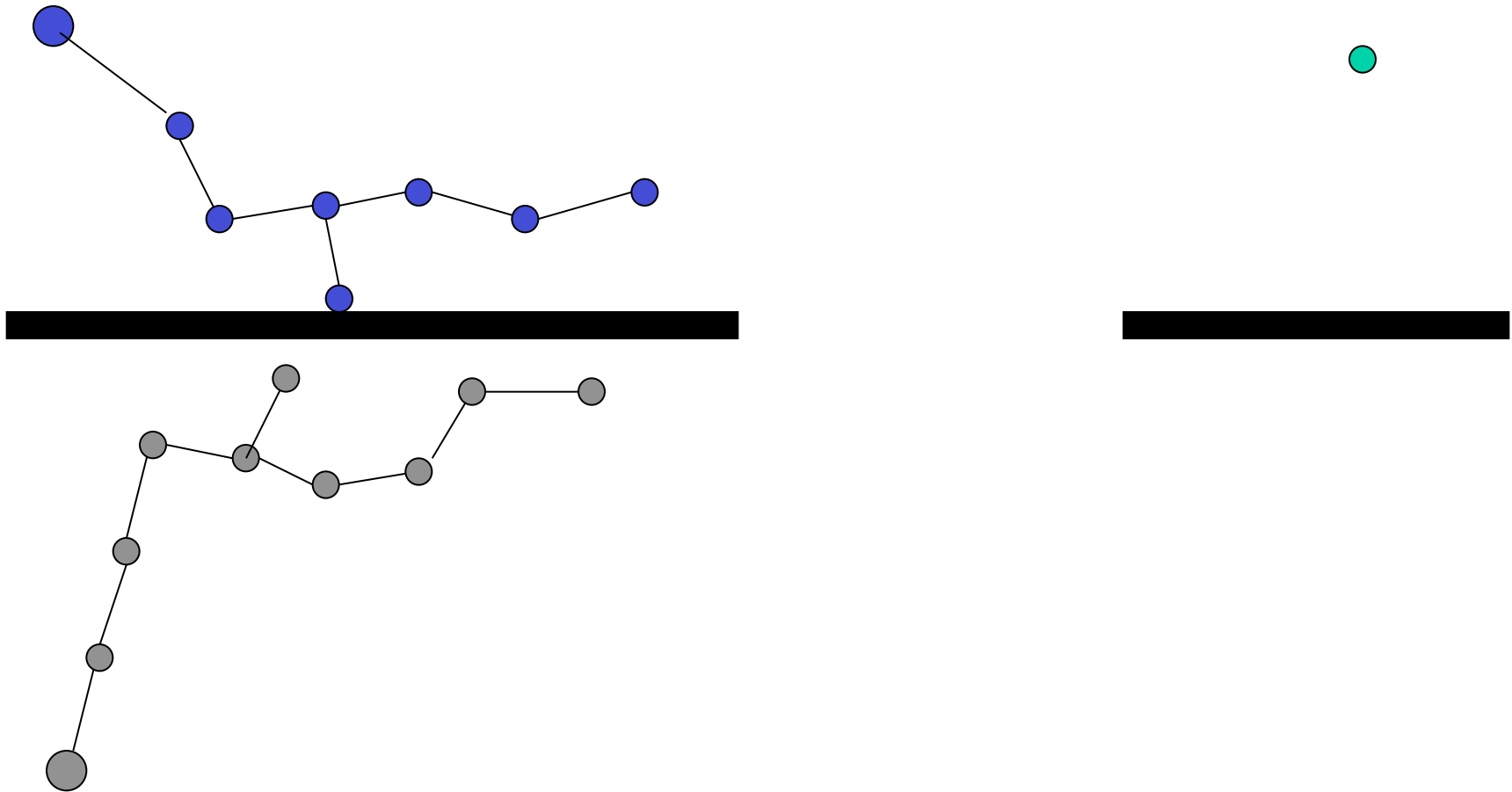

RRT-Connect: example

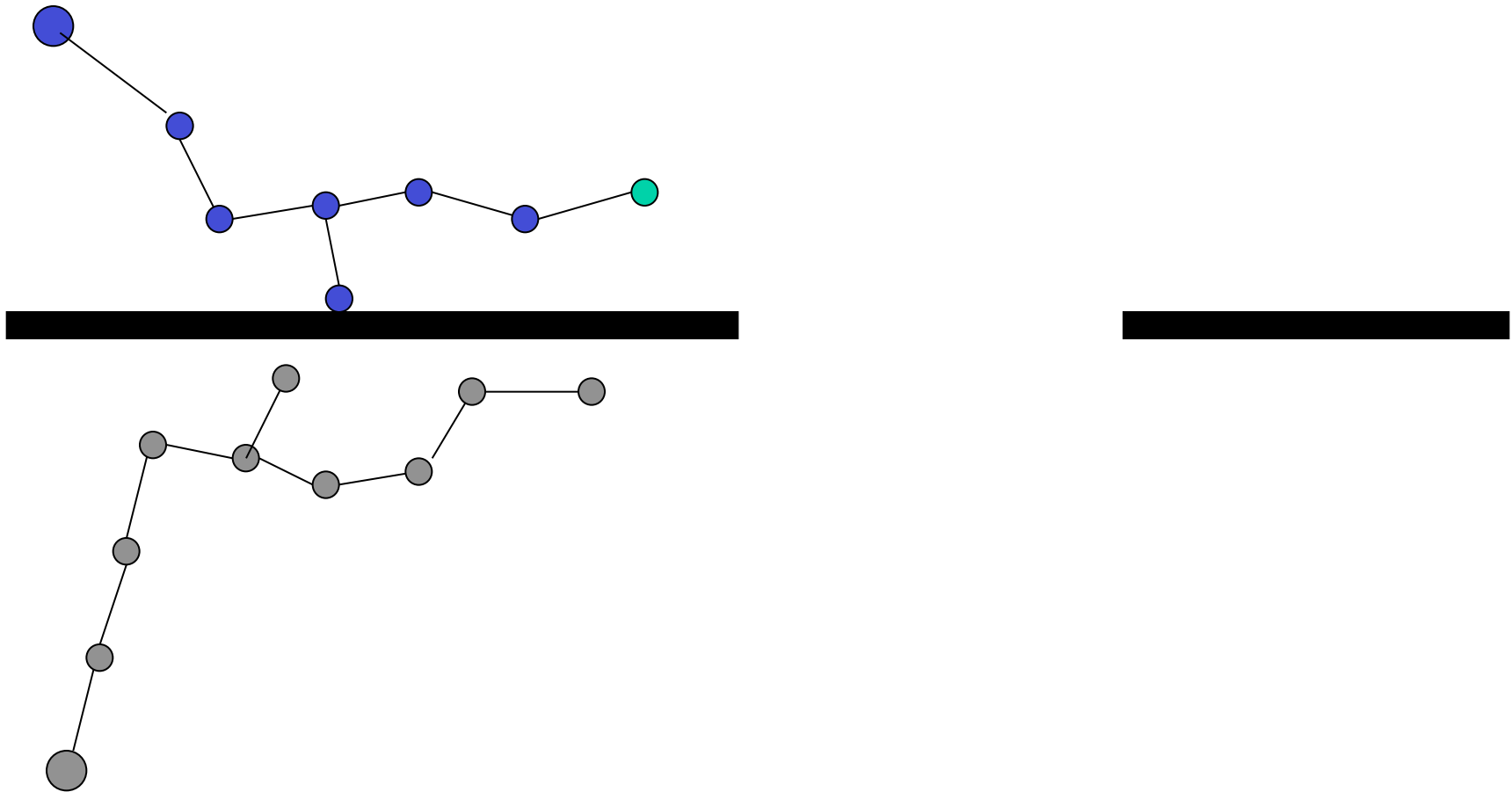

RRT-Connect: example

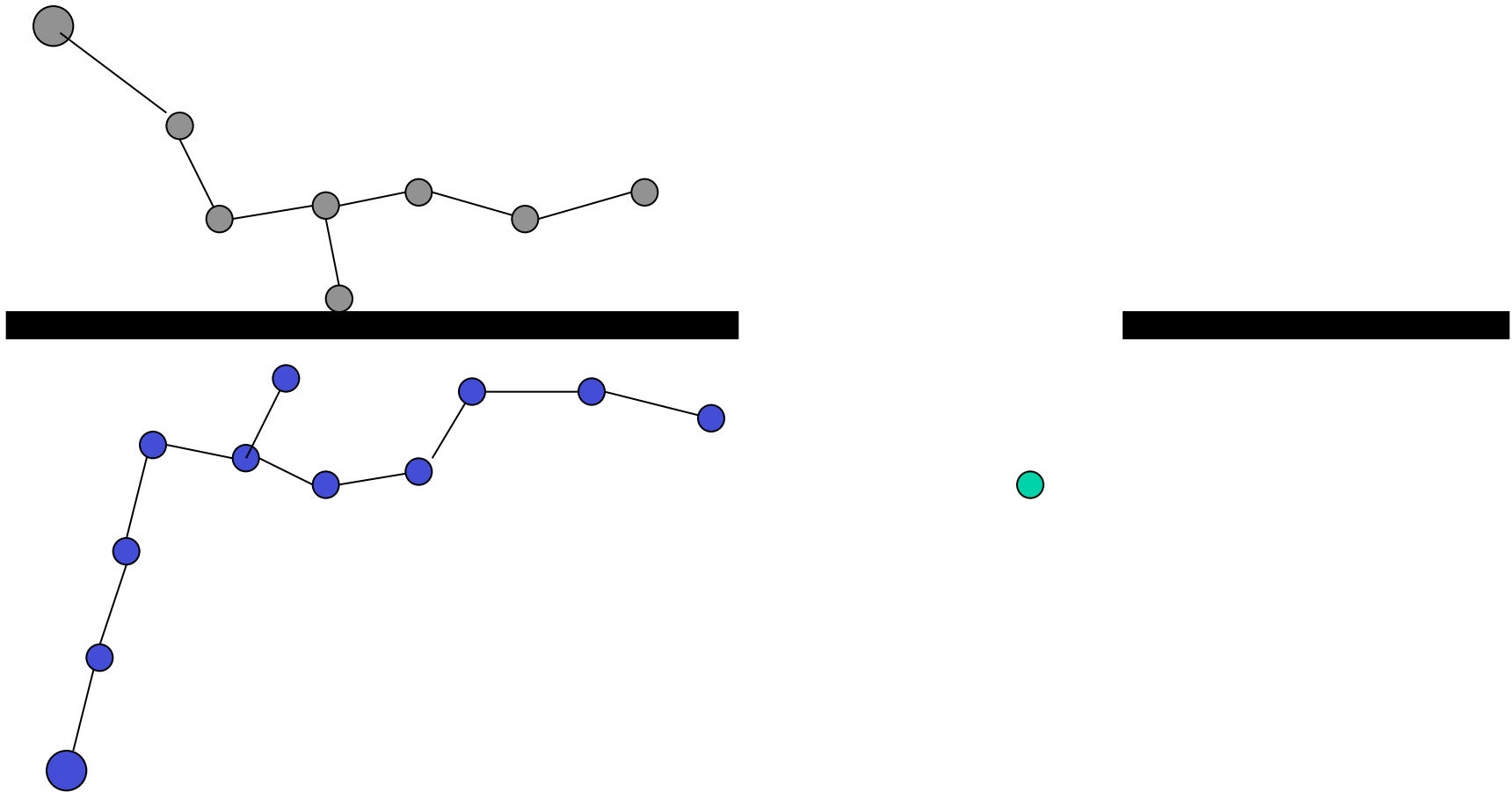

RRT-Connect: example

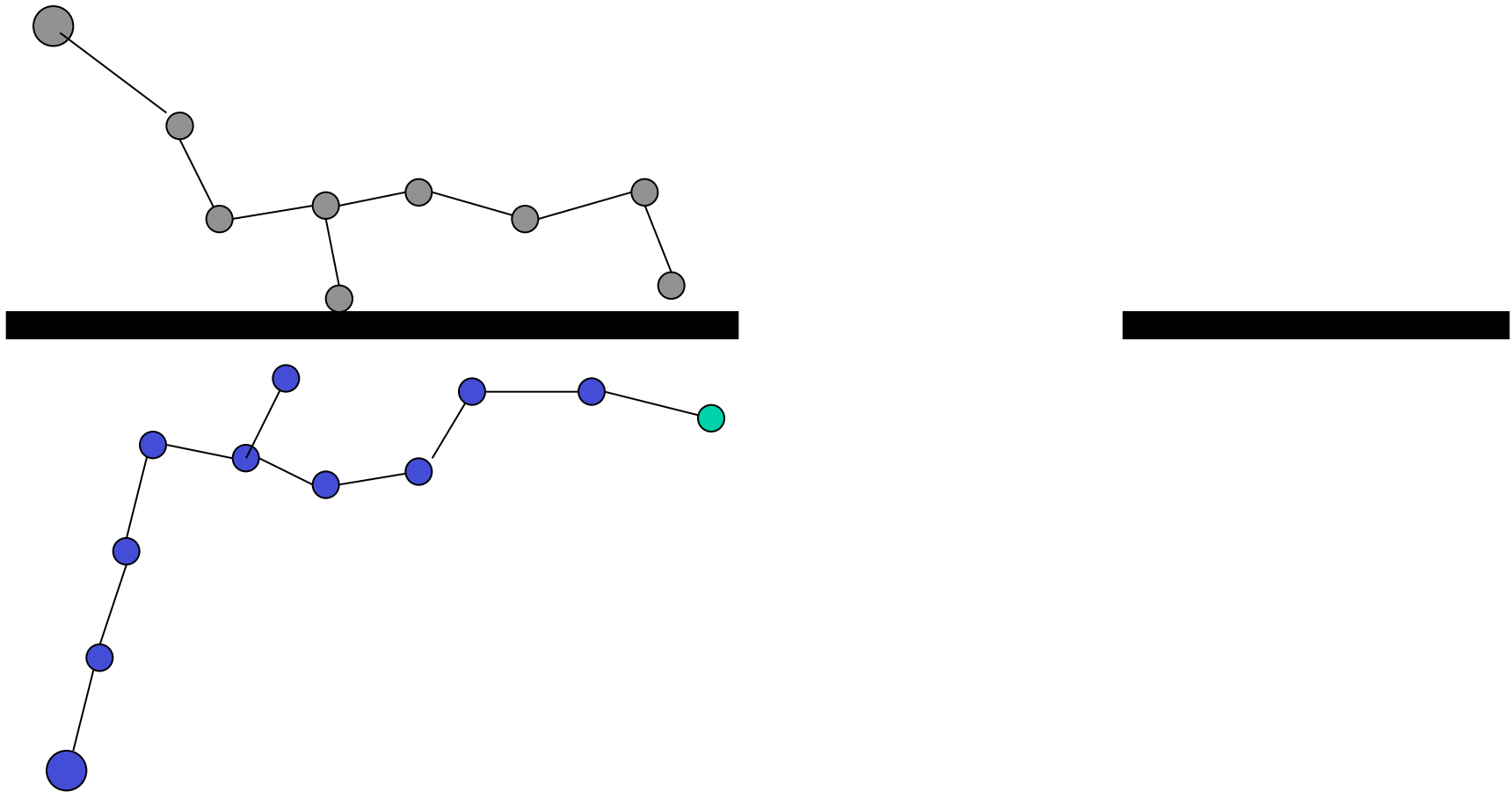

RRT-Connect: example

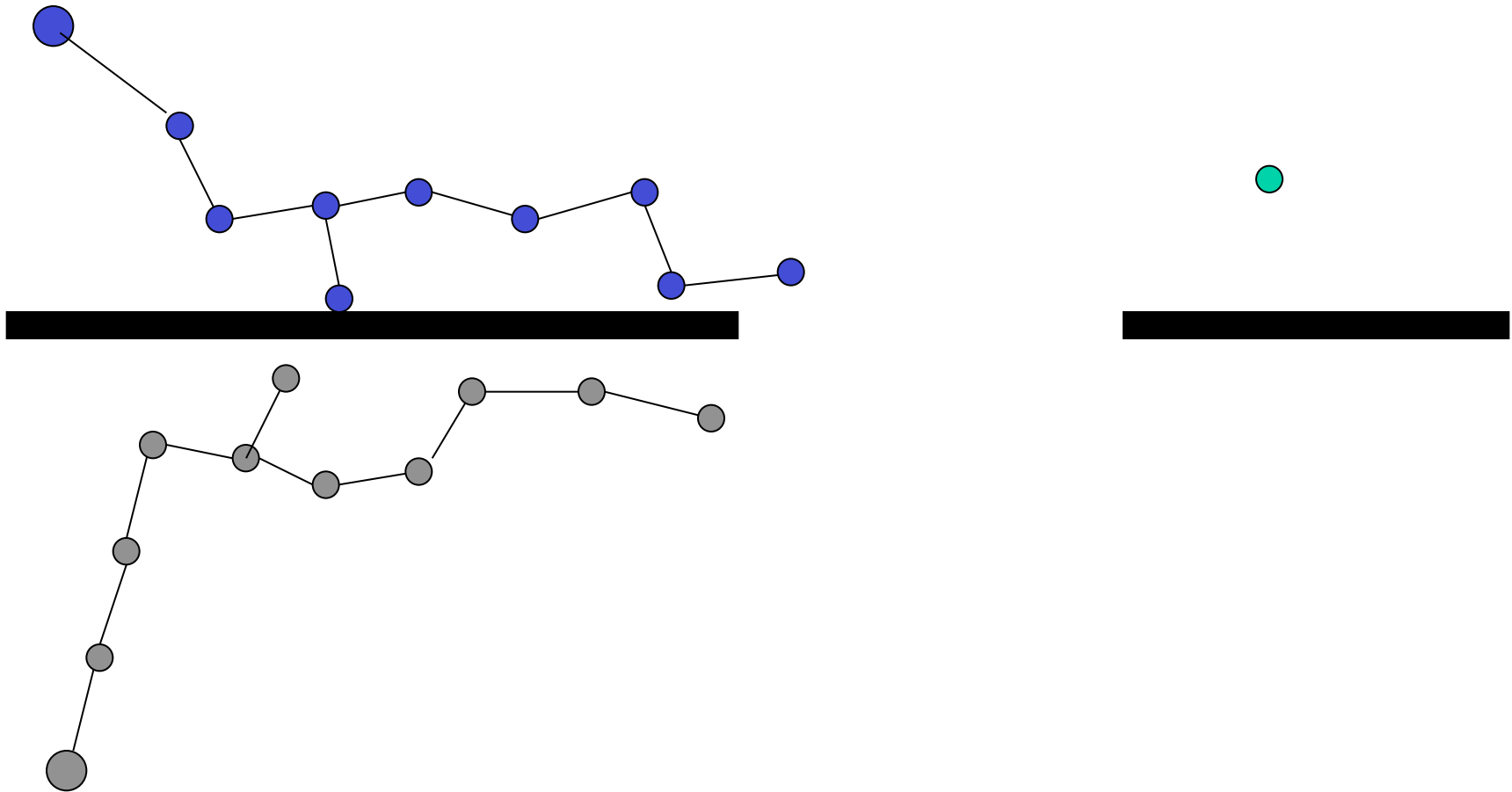

RRT-Connect: example

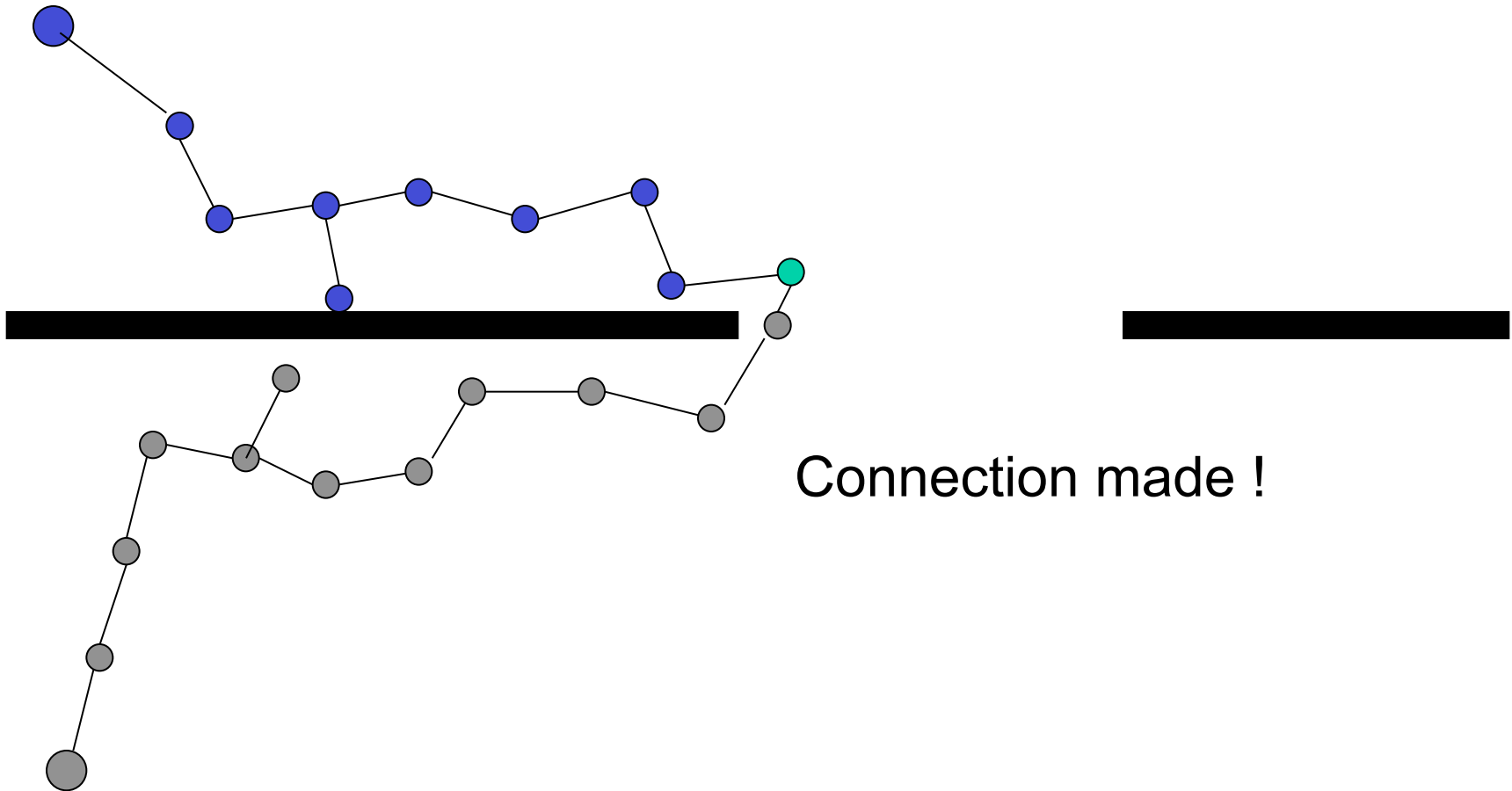

RRT-Connect: example

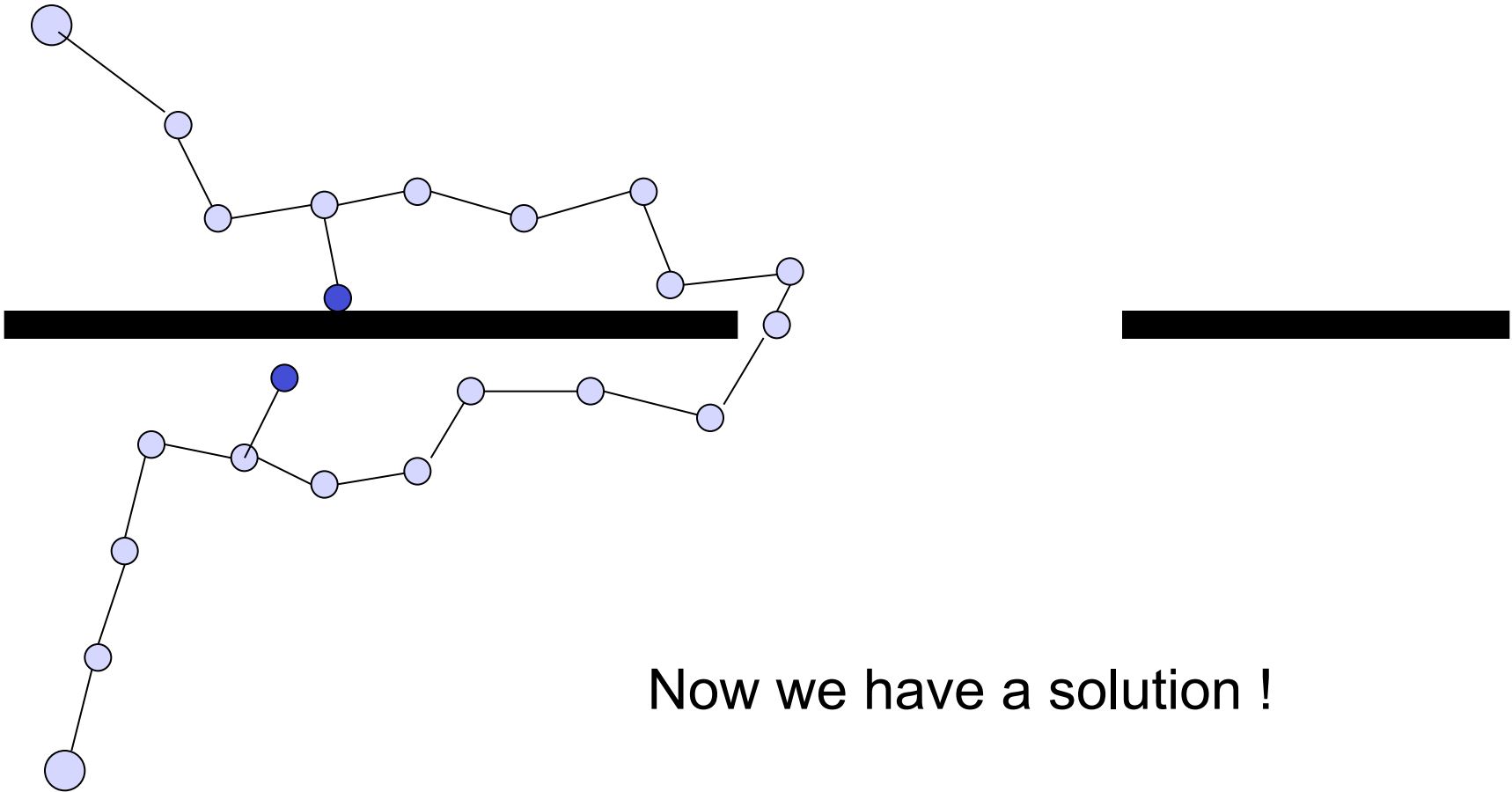

Now we have a solution !



RRT-Connect: example

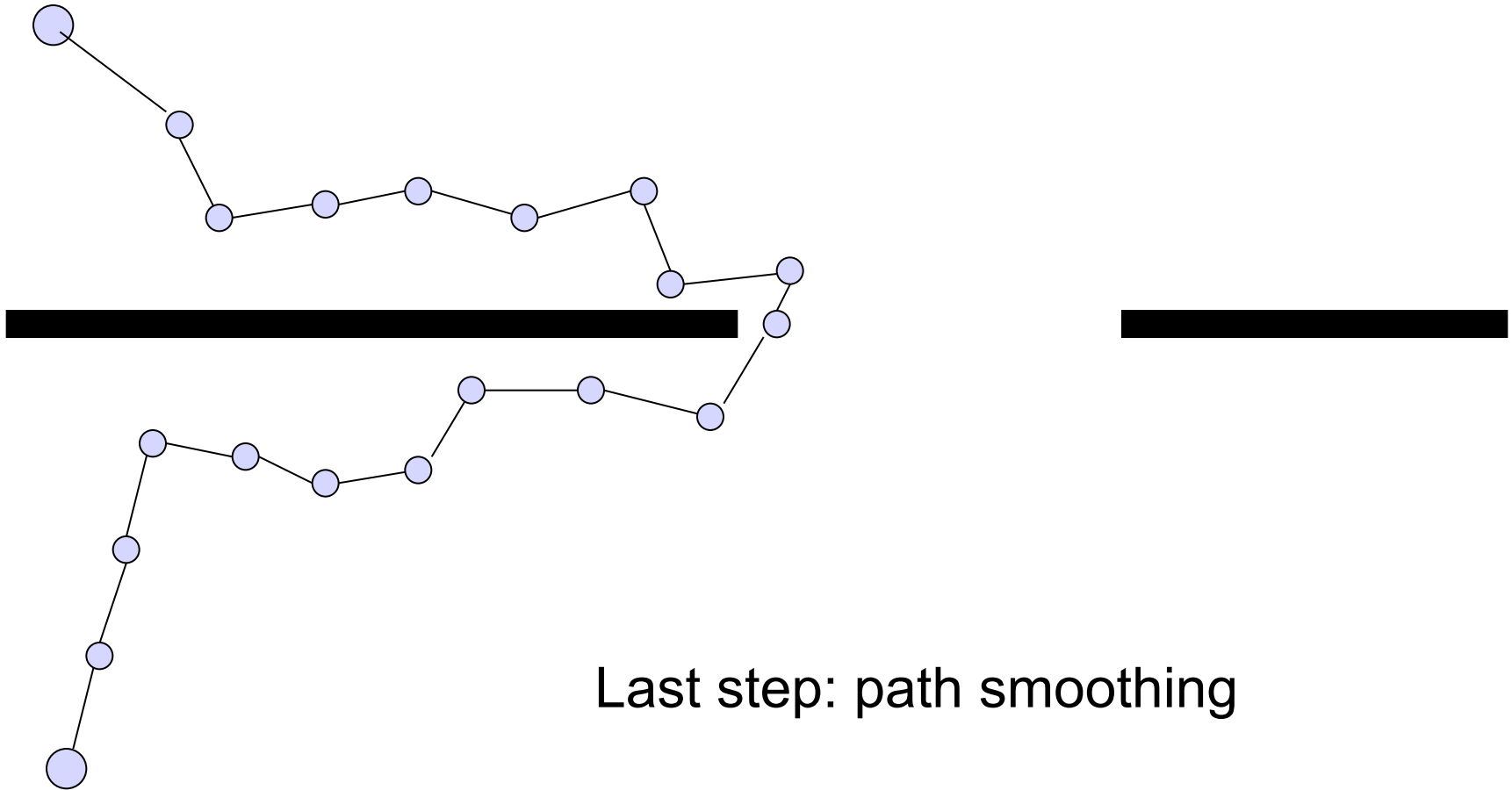

RRT-Connect: example

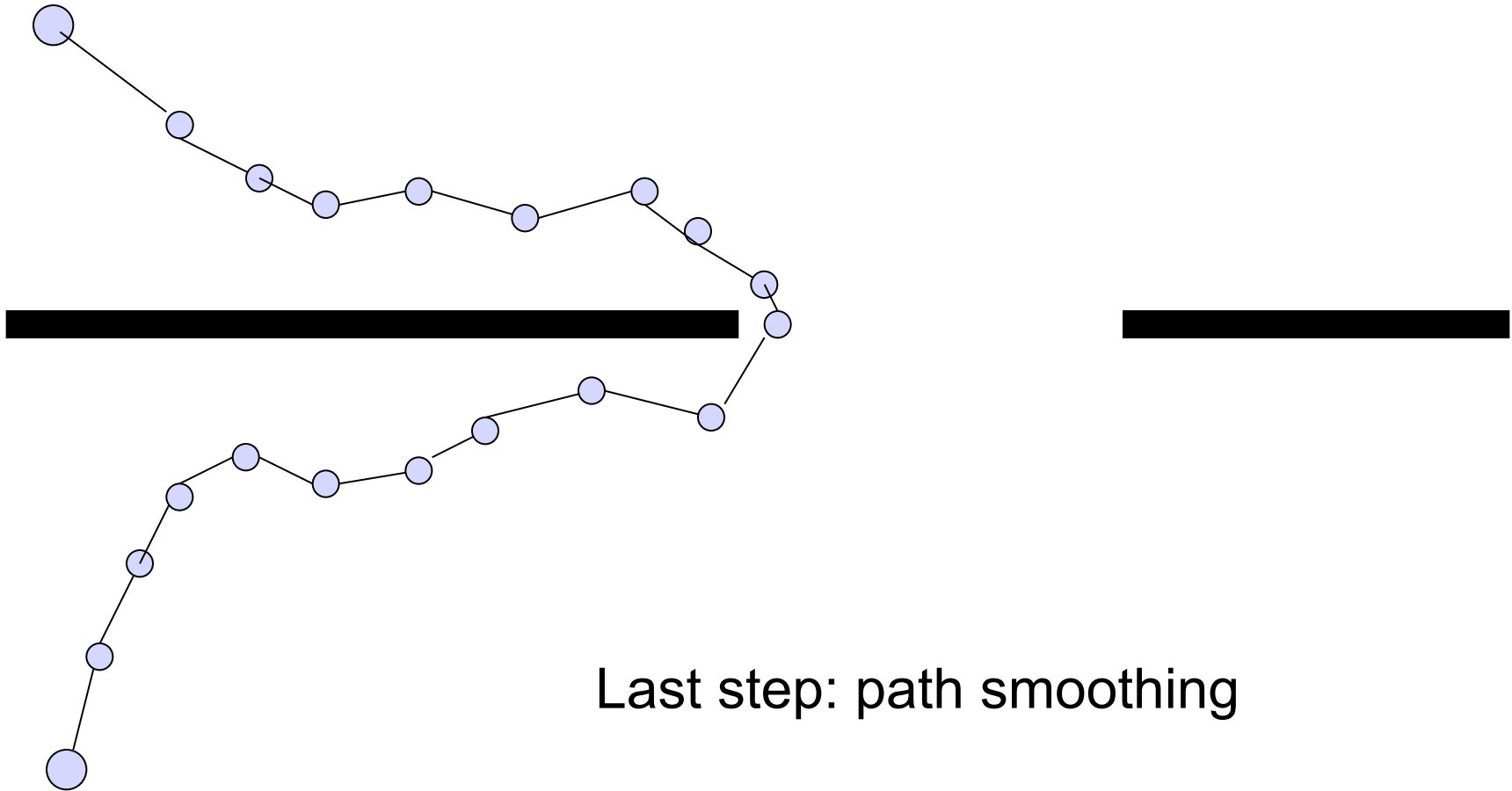

An RRT in 2D

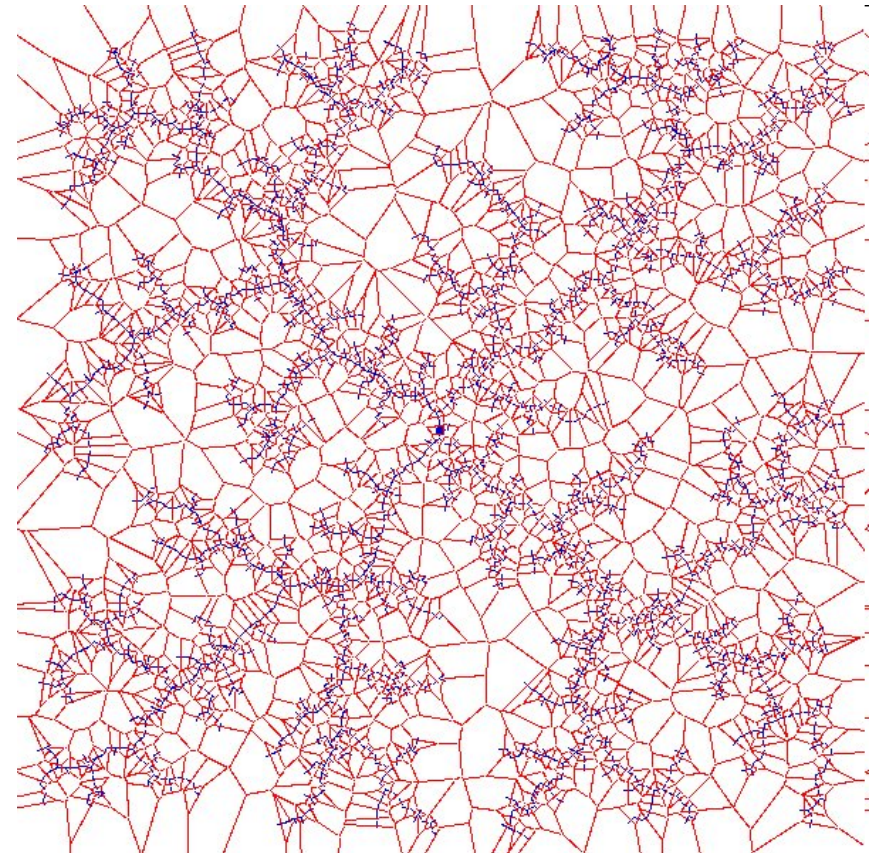
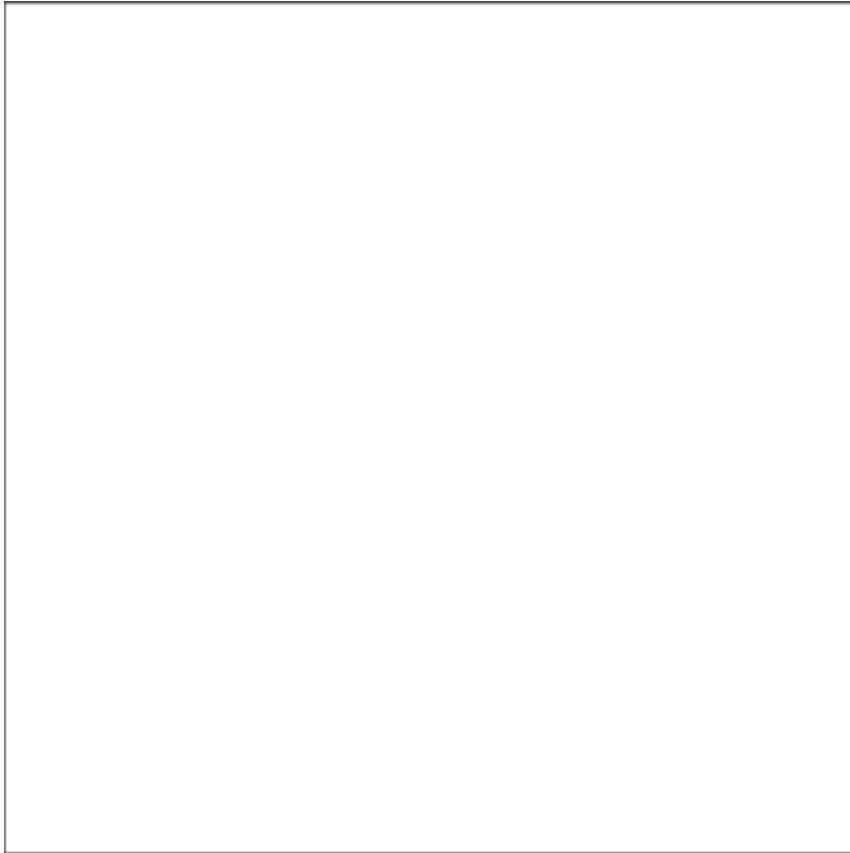

Example from: http://msl.cs.uiuc.edu/rrt/gallery_2drirt.html

CSCE-574.Robotics

A Puzzle solved using RRTs

The goal is to separate the two bars from each other. You might have seen a puzzle like this before. The example was constructed by Boris Yamrom, GE Corporate Research & Development Center, and posted as a research benchmark by Nancy Amato at Texas A&M University. It has been cited in many places as one of the most challenging motion planning examples. In 2001, it was solved by using a balanced bidirectional RRT, developed by James Kuffner and Steve LaValle. There are no special heuristics or parameters that were tuned specifically for this problem. On a current PC (circa 2003), it consistently takes a few minutes to solve.

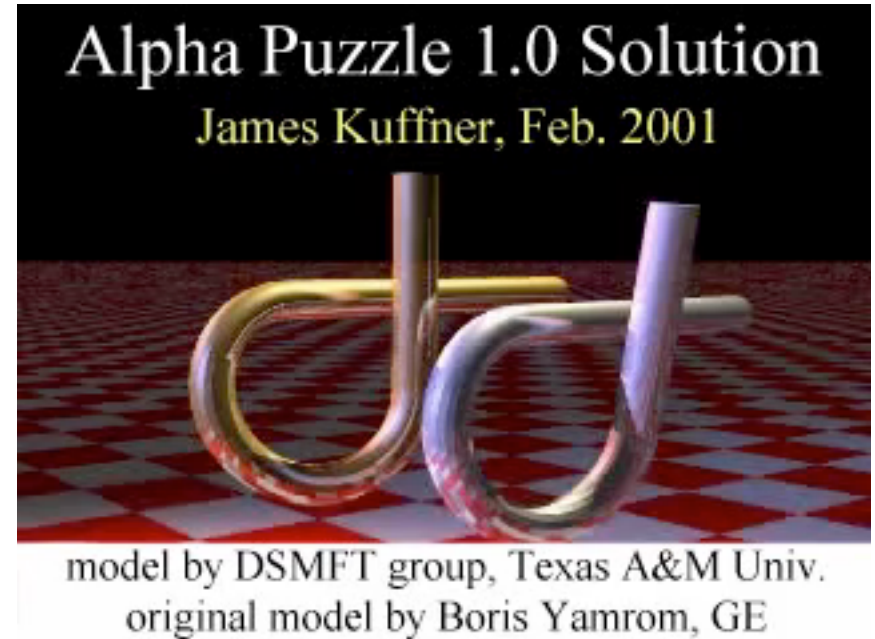

Lunar Landing

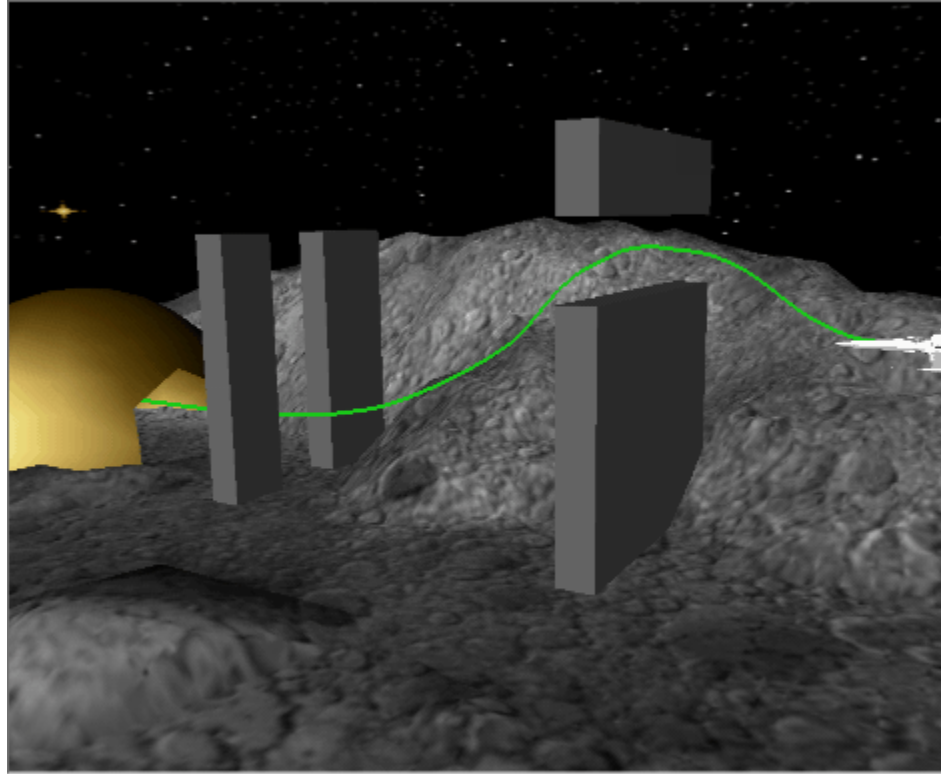

The following is an open loop trajectory that was planned in a 12-dimensional state space. The video shows an X-Wing fighter that must fly through structures on a lunar base before entering the hangar. This result was presented by Steve LaValle and James Kuffner at the Workshop on the Algorithmic Foundations of Robotics, 2000.

