



UNIVERSITY OF
SOUTH CAROLINA

CSCE 574 ROBOTICS

Sensors and Actuators

Robot Sensors

- Sensors are devices that can sense and measure physical properties of the environment,
 - e.g. temperature, luminance, resistance to touch, weight, size, etc.
 - The key phenomenon is transduction
 - Transduction (engineering) is a process that converts one type of energy to another
- They deliver *low-level* information about the environment the robot is working in.
 - Return an incomplete description of the world.



Robot Sensors

- This information is **noisy** (imprecise).
- Cannot be modelled completely:
 - Reading = $f(\text{env})$ where f is the model of the sensor
 - Finding the inverse:
 - ill posed problem (solution not uniquely defined)
 - collapsing of dimensionality leads to ambiguity



Types of sensor

- General classification:
 - **active versus passive**
 - Active: emit energy in environment
 - More robust, less efficient
 - Passive: passively receive energy from env.
 - Less intrusive, but depends on env. e.g. light for camera
 - Example: stereo vision versus range finder.
 - **contact versus non-contact**



Sensors

- **Proprioceptive Sensors**

(monitor state of robot)

- IMU (accels & gyros)
- Wheel encoders
- Doppler radar ...



- **Exteroceptive Sensors**

(monitor environment)

- Cameras (single, stereo, omni, FLIR ...)
- Laser scanner
- MW radar
- Sonar
- Tactile...



Sensor Characteristics

- All sensors are characterized by various properties that describe their capabilities
 - **Sensitivity:**
(change of output) \div (change of input)
 - **Linearity:** constancy of (output \div input)
 - Exception: logarithmic response cameras == wider dynamic range.
 - **Measurement/Dynamic range:**
difference between min. and max.



Sensor Characteristics

- **Response Time:** time required for a change in input to cause a change in the output
- **Accuracy:** difference between measured & actual
- **Repeatability:** difference between repeated measures
- **Resolution:** smallest observable increment
- **Bandwidth:** result of high resolution or cycle time



Types of sensor

Specific examples

- tactile
- close-range proximity
- angular position
- infrared
- Sonar
- laser (various types)
- radar
- compasses, gyroscopes
- Force
- GPS
- vision

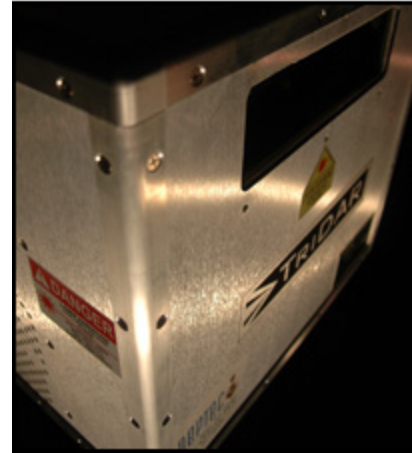

Tactile Sensors

- There are many different technologies
 - e.g. contact closure, magnetic, piezoelectric, etc.
- For mobile robots these can be classified as
 - tactile feelers (antennae) often some form of metal wire passing through a wire loop - can be active (powered to mechanically search for surfaces)
 - tactile bumpers
 - solid bar / plate acts on some form of contact switch
 - e.g. mirror deflecting light beam, pressure *bladder*, wire loops, etc.
 - Pressure-sensitive rubber with scanning array

“last line of defense”

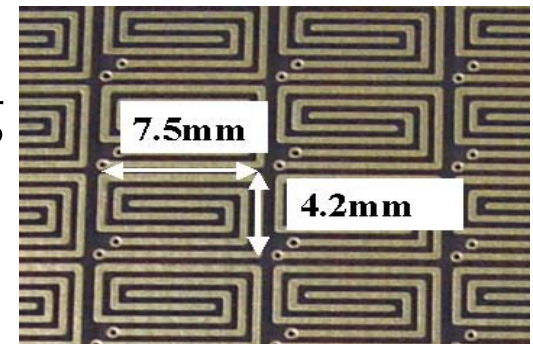

Tactile Sensors (more)

- Vibrissae/whiskers of rats
 - Surface texture information.
 - Distance of deflection.
 - Blind people using a cane.



Proximity Sensors

- Tactile sensors allow obstacle *detection*
 - proximity sensors needed for true obstacle *avoidance*
- Several technologies can detect the presence of particular fields without mechanical contact
 - magnetic reed switches
 - two thin magnetic strips of opposite polarity not quite touching
 - an external magnetic field closes the strip & makes contact



Proximity Sensors

- Hall effect sensors
 - small voltage generated across a conductor carrying current $V_H \propto I \times B$
- inductive sensors, capacitive sensors
 - inductive sensors can detect presence of metallic objects
 - capacitive sensors can detect metallic or dielectric materials



Infrared Sensors

- Infrared sensors are probably the simplest type of non-contact sensor
 - widely used in mobile robotics to avoid obstacles
- They work by
 - emitting infrared light
 - to differentiate emitted IR from ambient IR (e.g. lights, sun, etc.), the signal is modulated with a low frequency (100 Hz)
 - detecting any reflections off nearby surfaces
- In certain environments, with **careful calibration**, IR sensors can be used for measuring the distance to the object
 - requires uniform surface colours and structures



Infrared Sensors (Sharp)

- Measures the return angle of the infrared beam.

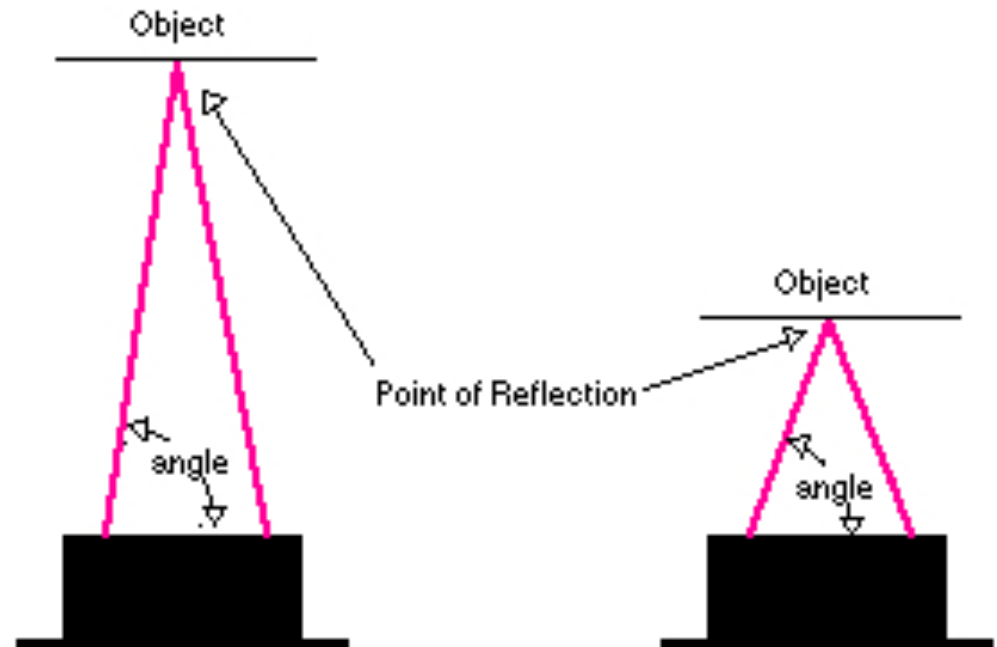

Infrared Problems

- If the IR signal is detected, it is safe to assume that an object is present
- However, the absence of reflected IR does not mean that no object is present!
 - “Absence of evidence is not evidence of absence.”
C. Sagan
 - certain dark colours (black) are almost invisible to IR
 - IR sensors are not absolutely safe for object detection
- In realistic situations (different colours & types of objects) there is no accurate distance information
 - it is best to avoid objects as soon as possible
- IR are short range
 - typical maximum range is 50 to 100 cm



Sonar Sensors

- The fundamental principle of robot sonar sensors is the same as that used by bats
 - emit a chirp (e.g. 1.2 milliseconds)
 - a short powerful pulse of a range of frequencies of sound
 - its reflection off nearby surfaces is detected
- As the speed of sound in air is known ($\approx 330 \text{ m}\cdot\text{s}^{-1}$) the distance to the object can be computed from the elapsed time between chirp and echo
 - minimum distance = $165 t_{chirp}$ (e.g. 21 cm at 1.2 ms)
 - maximum distance = $165 t_{wait}$ (e.g. 165 m at 1 s)
- Usually referred to as *ultrasonic sensors*

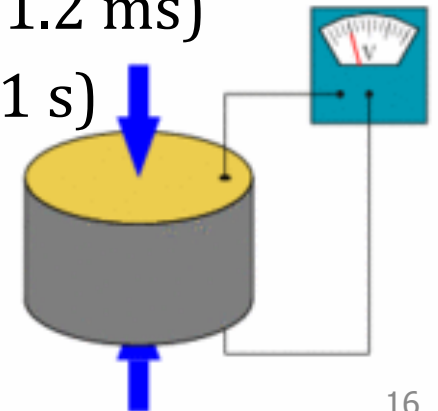

Sonar Problems

- There are a number of problems and uncertainties associated with readings from sonar sensors
 - it is difficult to be sure in which direction an object is because the 3D sonar beam spreads out as it travels
 - *specular reflections* give rise to erroneous readings
 - the sonar beam hits a smooth surface at a shallow angle and so reflects away from the sensor
 - only when an object further away reflects the beam back does the sensor obtain a reading - *but distance is incorrect*
 - arrays of sonar sensors can experience *crosstalk*
 - one sensor detects the reflected beam of another sensor
 - the speed of sound varies with air temp. and pressure
 - a 16° C temp. change can cause a 30cm error at 10m!



Laser Range Finders

- Laser range finders commonly used to measure the *distance, velocity* and *acceleration* of objects
 - also known as *laser radar* or *lidar*
- The operating principle is the same as sonar
 - a short pulse of (laser) light is emitted
 - the time elapsed between emission and detection is used to determine distance (using the speed of light)
- Due to the shorter wavelengths of lasers, the chance of specular reflections is much less
 - accuracies of millimetres (16 - 50mm) over 100m
 - 1D beam is usually swept to give a 2D planar beam
- May not detect transparent surfaces (e.g. glass!) or dark objects



RADAR

- Radar usually uses electromagnetic energy in the 1 - 12.5 GHz frequency range
 - this corresponds to wavelengths of 30 cm - 2 cm
 - microwave energy
 - unaffected by fog, rain, dust, haze and smoke
- It may use a pulsed time-of-flight methodology of sonar and lidar, but may also use other methods
 - continuous-wave phase detection
 - continuous-wave frequency modulation
- Continuous-wave systems make use of Doppler effect to measure relative velocity of the target



Angular Position: Rotary Encoder

- Potentiometer
 - Used in the Servo on the boebots
- Optical Disks (Relative)
 - Counting the slots
 - Direction by having pairs of emitters/receivers out of phase: Quadrature decoding
 - Can spin very fast: 500 kHz

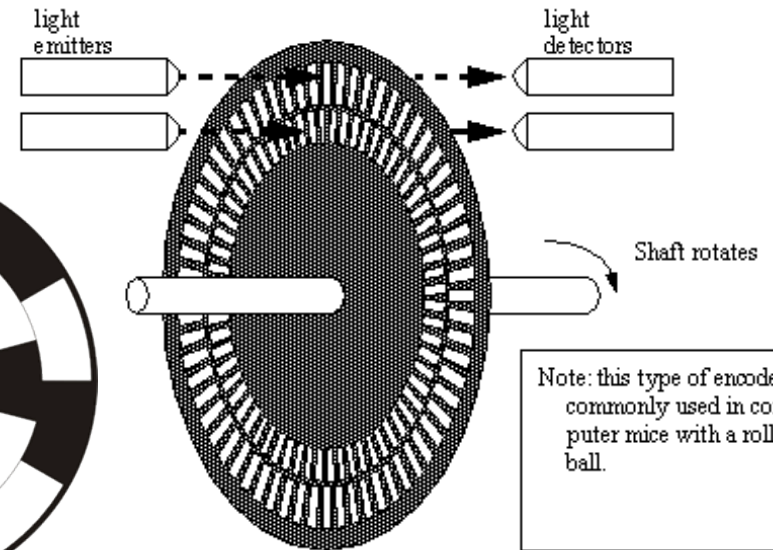
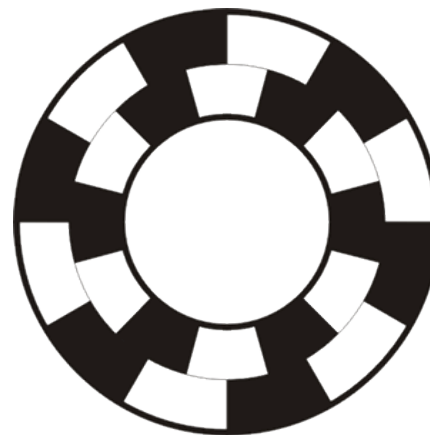
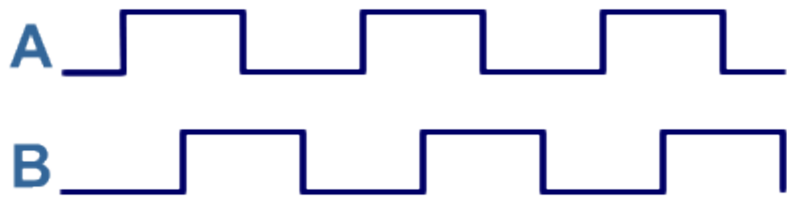
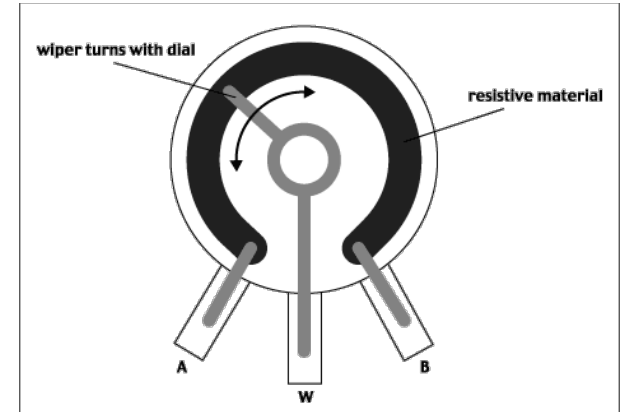

Angular Position: Rotary Encoder

- Optical Disks (Absolute)
 - Grey encoding for absolute:
 - 0:0000, 1:1000, 2:1100, 3:0100, 4:0110,
 - 5:1110, 6:1010, 7:0010, 8:0011
 - 9:1011, 10:1111, 11:0111, 12:0101, 13:1101, 14:1001, 15:0001

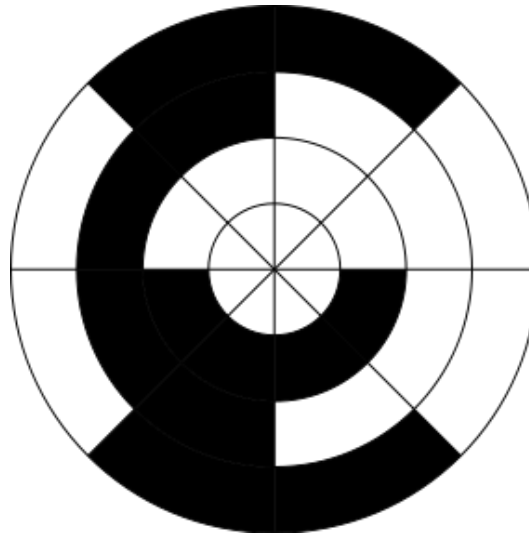

Compass Sensors

- Compass sensors measure the horizontal component of the earth's magnetic field
 - some birds use the vertical component too
- The earth's magnetic field is very **weak** and **non-uniform**, and **changes over time**
 - indoors there are likely to be many other field sources
 - steel girders, reinforced concrete, power lines, motors, etc.
 - an accurate absolute reference is unlikely, but the field is approx. constant, so can be used for local reference



Gyroscopes

- A gyroscope is a spinning wheel with most of its mass concentrated in the outer periphery
 - e.g. a bicycle wheel
- Due to the law of *conservation of momentum*
 - the spinning wheel will stay in its original orientation
 - a force is required to rotate the gyroscope
- A gyro. can thus be used to maintain orientation or to measure the rate and direction of rotation
- In fact there are different types of mechanical gyro.
 - and even optical gyro's with no moving parts!
 - these can be used in e.g. space probes to maintain orientation



Vibrating Structure Gyroscopes

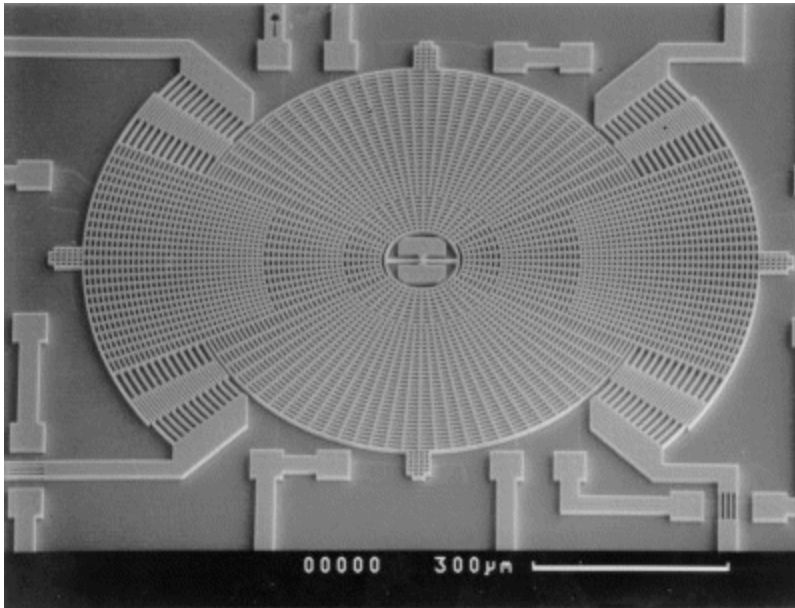

MEMS

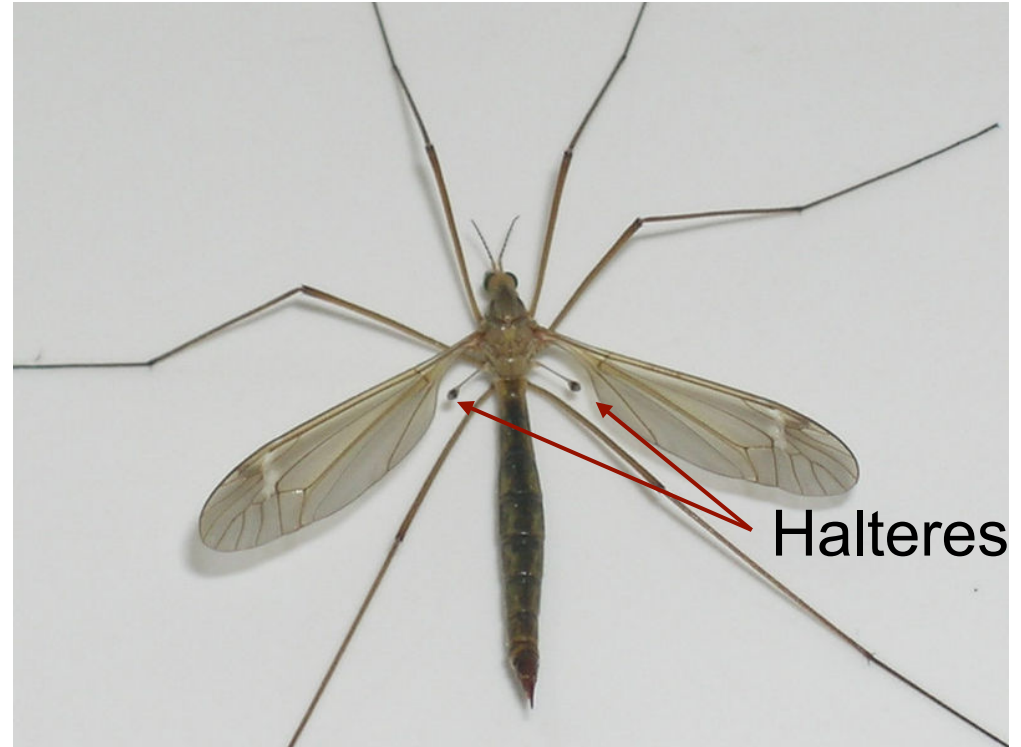

Ring gyro's

- Use standing waves set up
 - between mirrors (laser ring gyro)
 - within a fiber optic cable (fibre optic ring gyro)
- Measure rotation by observing beats in standing wave as the mirrors "rotate through it".



IMU's

- Gyro, accelerometer combination.
- Typical designs (e.g. 3DM-GX1™) use tri-axial gyros to track dynamic orientation and tri-axial DC accelerometers along with the tri-axial magnetometers to track static orientation.
- The embedded microprocessors contains programmable filter algorithms, which blend these static and dynamic responses in real-time.

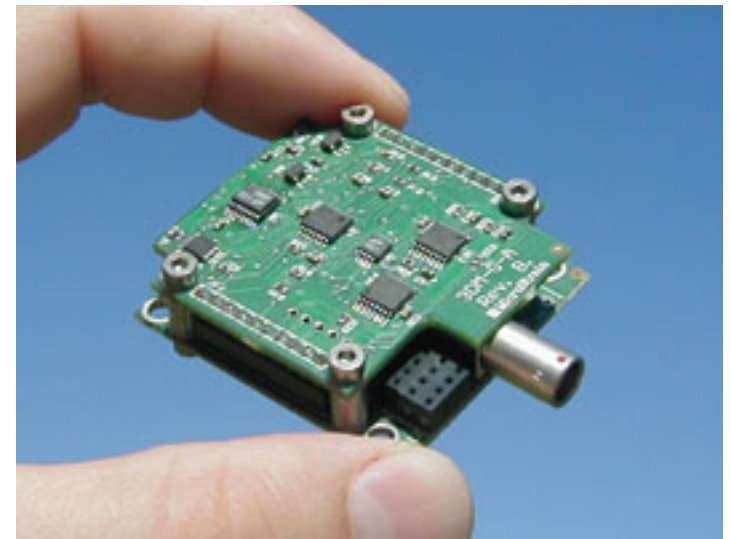

GPS

- GPS uses a constellation of between 24 and 32 Medium Earth Orbit satellites.
- Satellite broadcast their position + time.
- Use travel time of 4 satellites and trilateration.
- Suffers from “canyon” effect in cities.



WiFi

- Using the SSID and database.



Odor sensing

Smell is ubiquitous in nature
... both as a active and a passive sensor.
Why is it so important?

Advantages: evanescent, controllable, multi-valued,
useful.

References:

- [1] T. Hayes, A. Martinoli, and R. M. Goodman. “Swarm Robotic Odor Localization: Off-Line Optimization and Validation with Real Robots”. Special issue on Biological Robotics, *Robotica*, Vol. 21, Issue 4, pp. 427-441, 2003. © Cambridge University Press
- [2] T. Yamanaka, R. Matsumoto, and T. Nakamoto, “Fundamental study of odor recorder for multi-component odor using recipe exploration method based on singular value decomposition”, *IEEE Sensors Journal*, Vol. 3, Issue 4, 2003, pp. 468-474.



What is an actuator?

- Device for moving or controlling a system.
- “Robot Muscles”



Hydraulic Actuators

- Pros:
 - Powerful
 - Fast
 - Stiff
- Cons
 - Messy
 - Maintenance
 - External Pump



Hydraulic Actuator Application

- BigDog from Boston Dynamics



Pneumatic Actuators

- Pros:
 - Powerful
 - Cheap
- Cons
 - Soft/Compliant
 - External Compressor

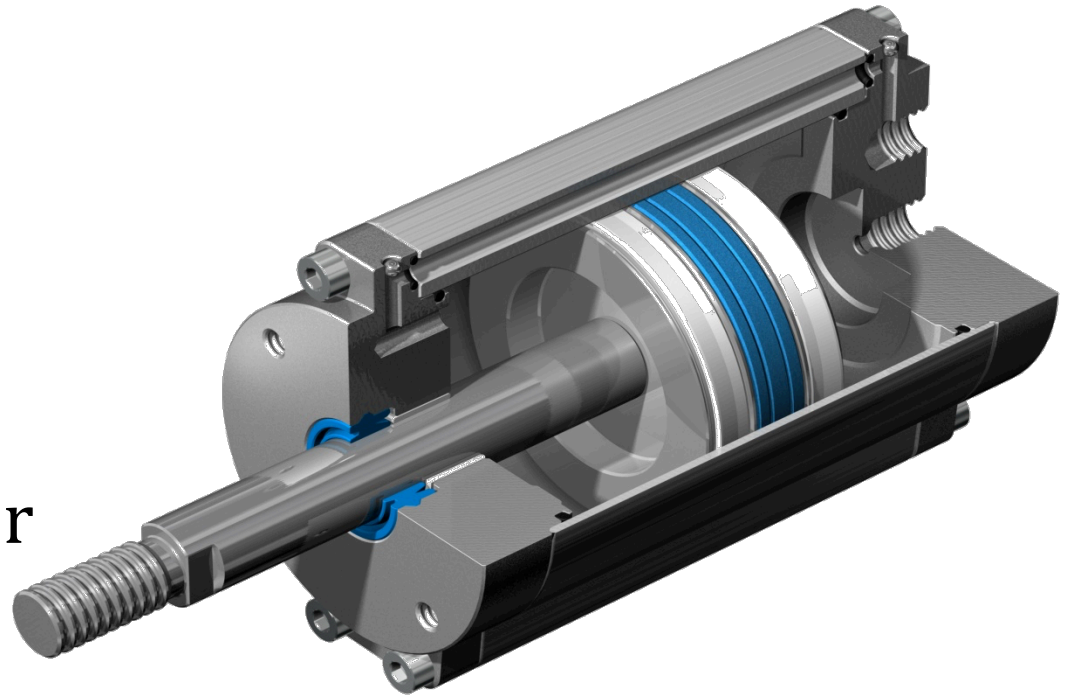

Pneumatic Actuators

- 3D Biped ('89-'95) from MIT Leg Lab

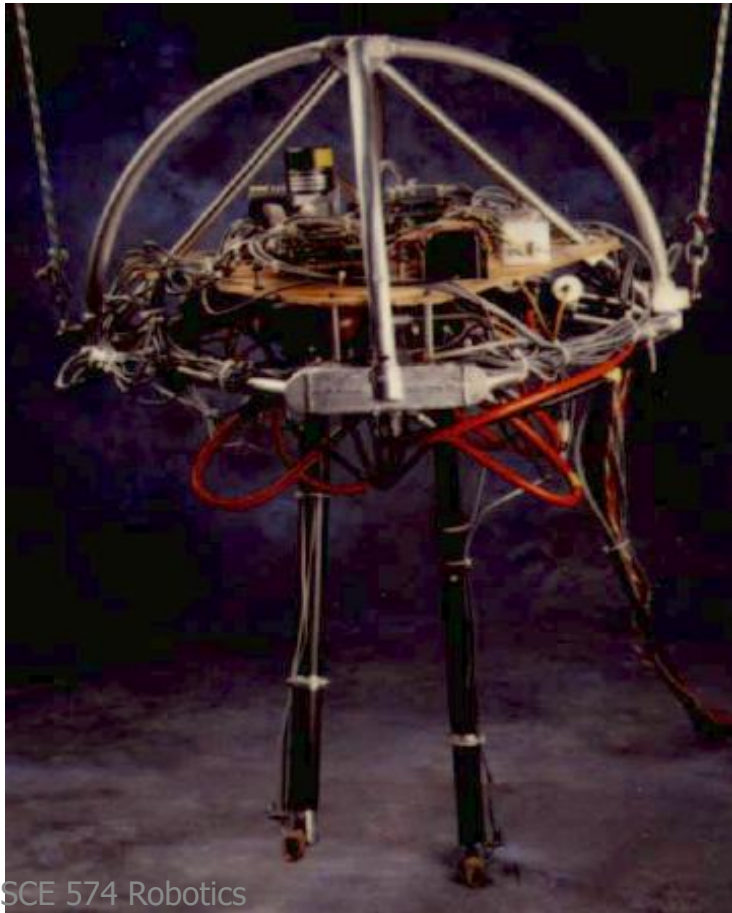

Air Muscle

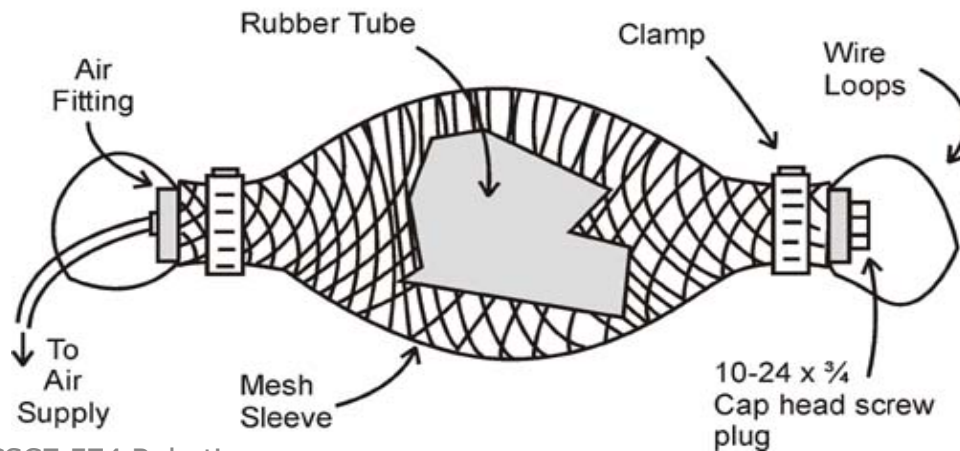
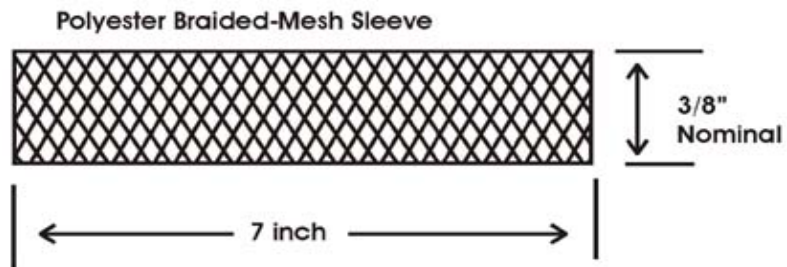
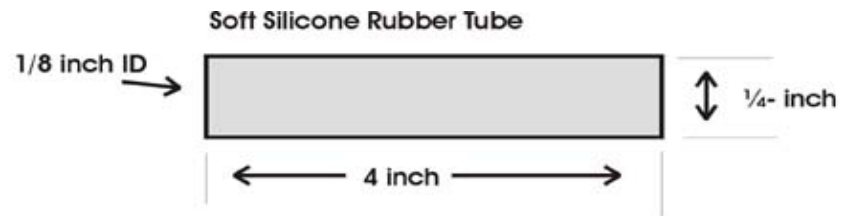

Air Muscle Application

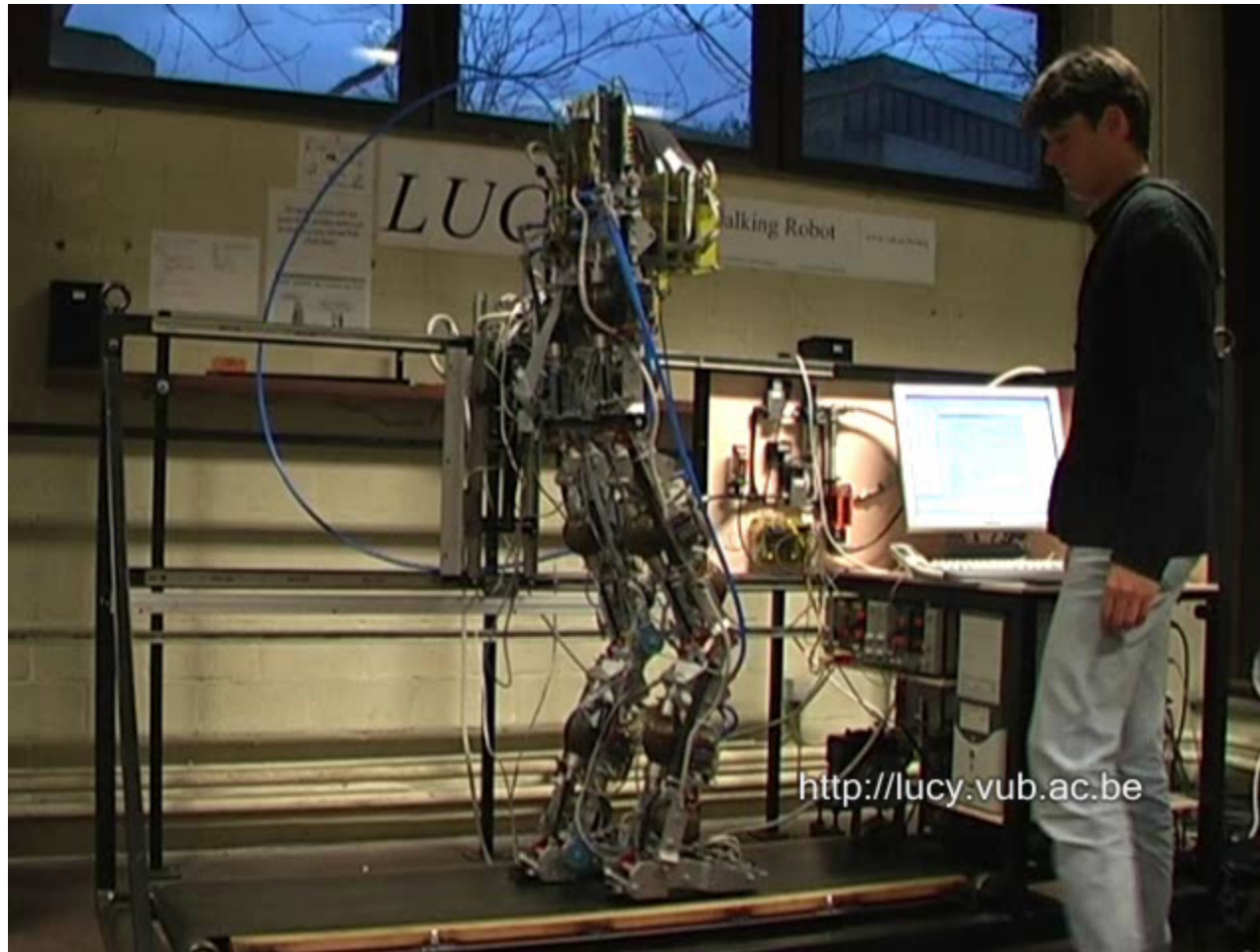

Air Muscle Application



Shape Memory Alloy Actuators

- Works by warming and cooling Nitinol wires.
- Pros:
 - Light
 - Powerful
- Cons:
 - Slow (cooling)

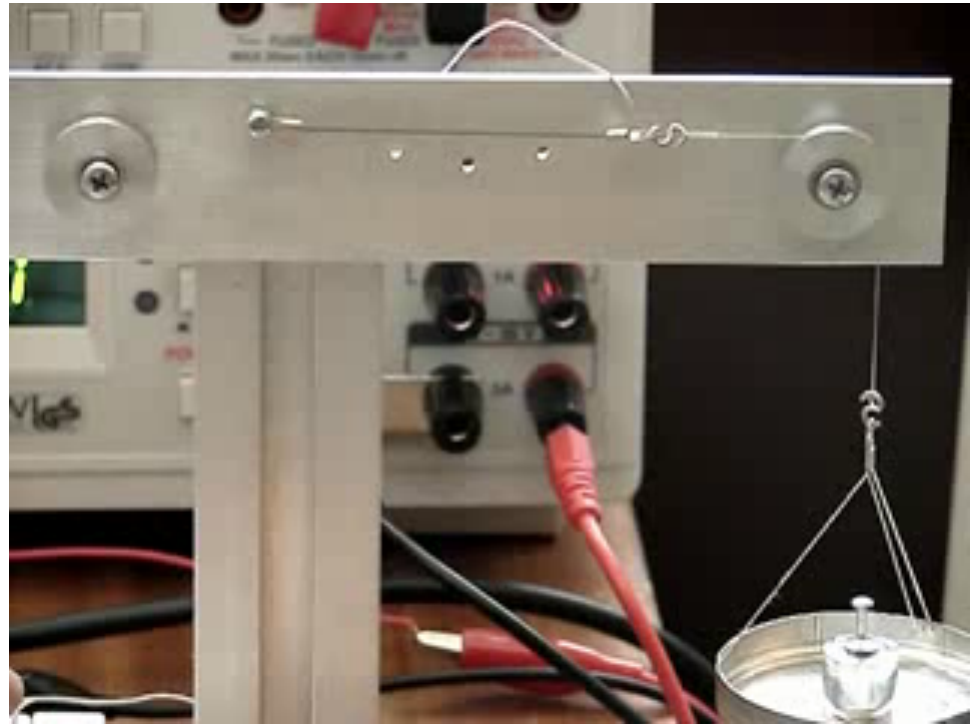

Stiquito

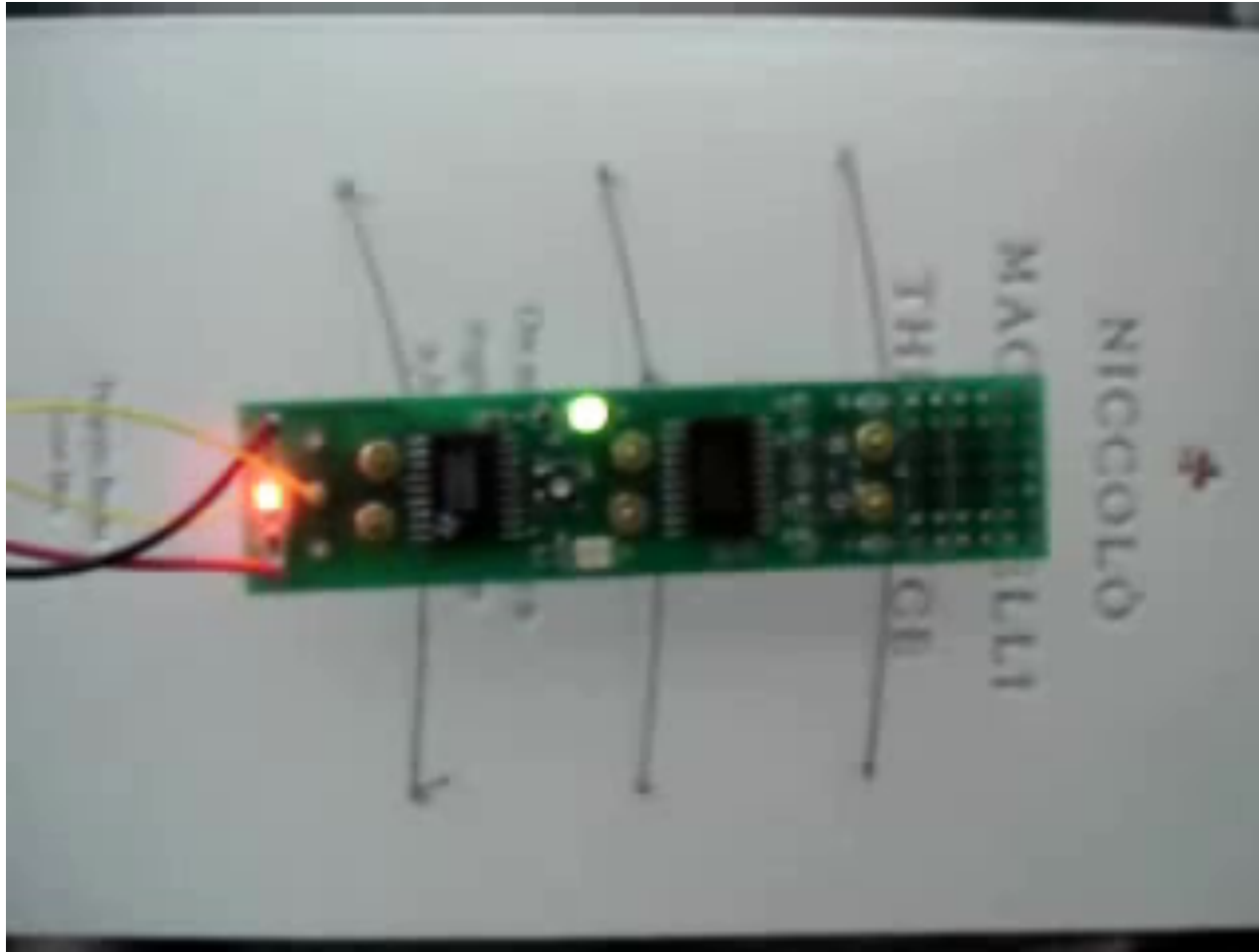

Jonathan Mills, Indiana University



Electric Actuators

- Pros
 - Better position precision
 - Well understood
 - No separate power source
 - Cheap
- Cons
 - Heavy
 - Weaker/slower than hydraulics
 - Cooling issue

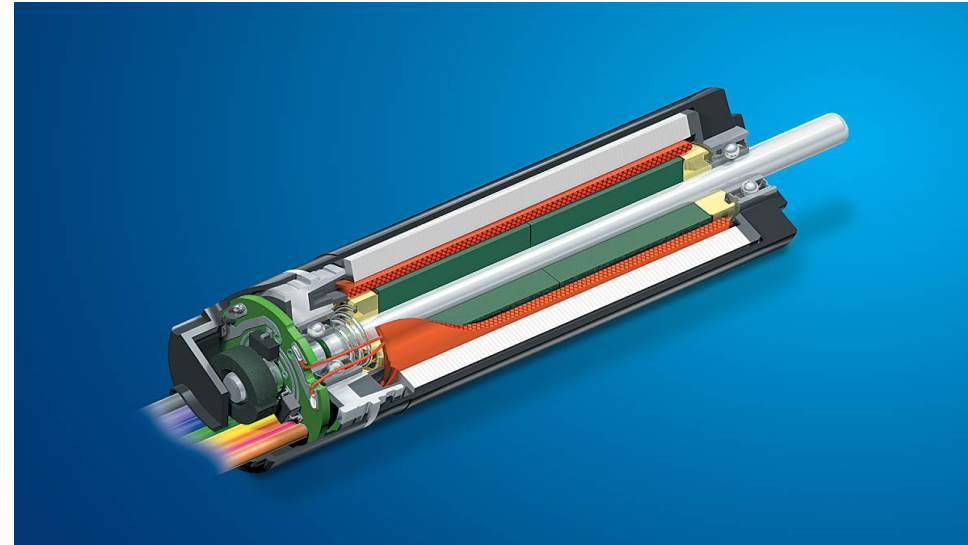

Electric Actuators

- Stepper motors
- DC motors
 - Servos
 - Continuous
 - Position
- Others (not discussed)
 - Linear actuators
 - AC motors



Stepper Motor Basics

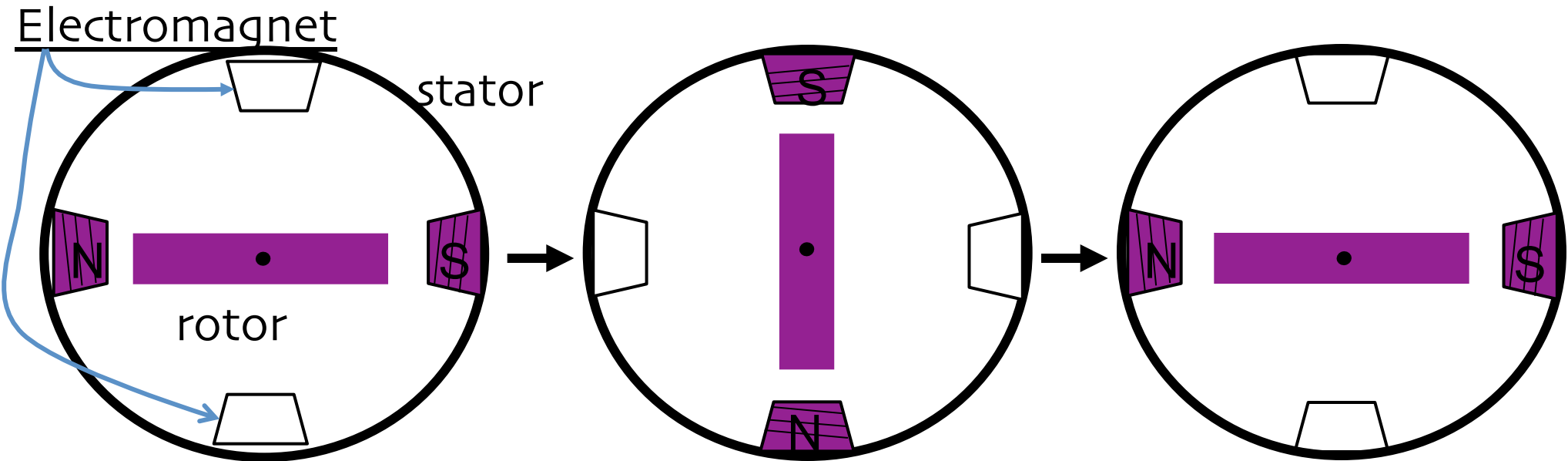

Stator: made out of coils of wire called “winding”

Rotor: magnet rotates on bearings inside the stator

- Direct control of rotor position (no sensing needed)
- May oscillate around a desired orientation (resonance at low speeds)
- Low resolution

printers
computer drives



Increased Resolution

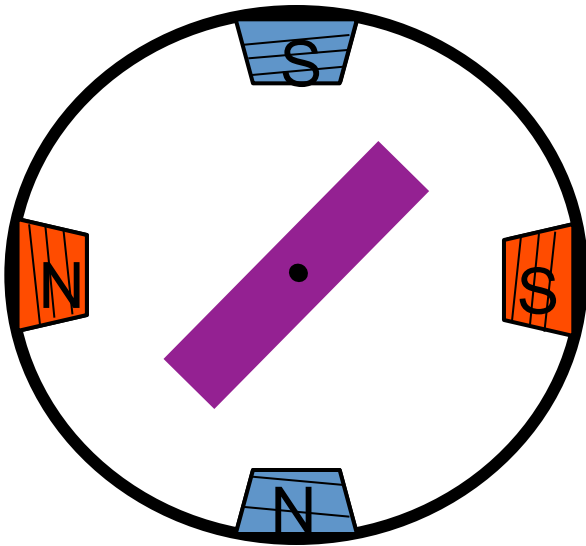

Half stepping

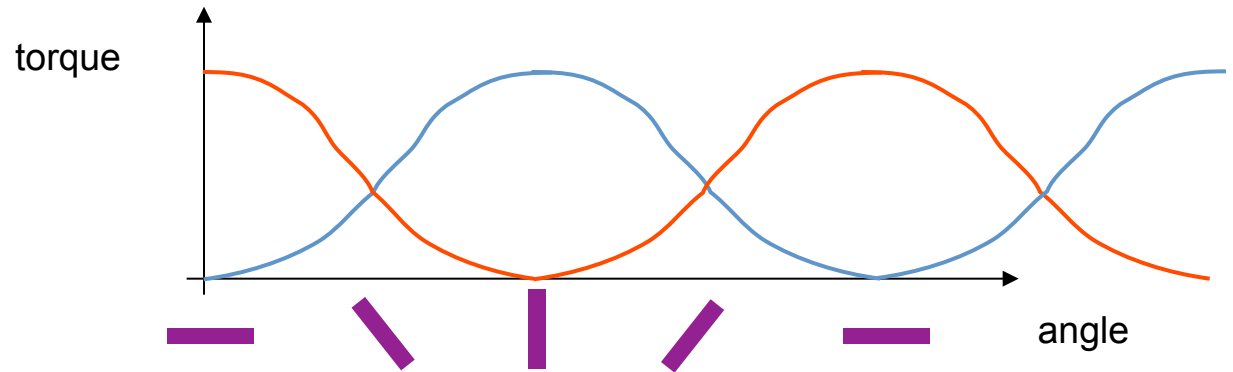

Increased Resolution

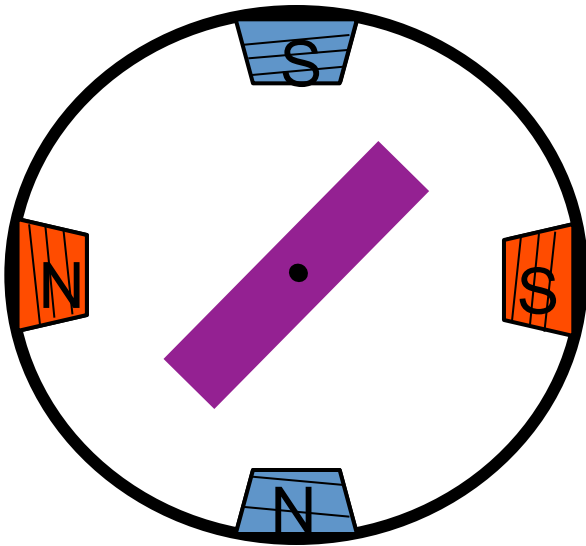

Half stepping

More teeth on rotor or stator

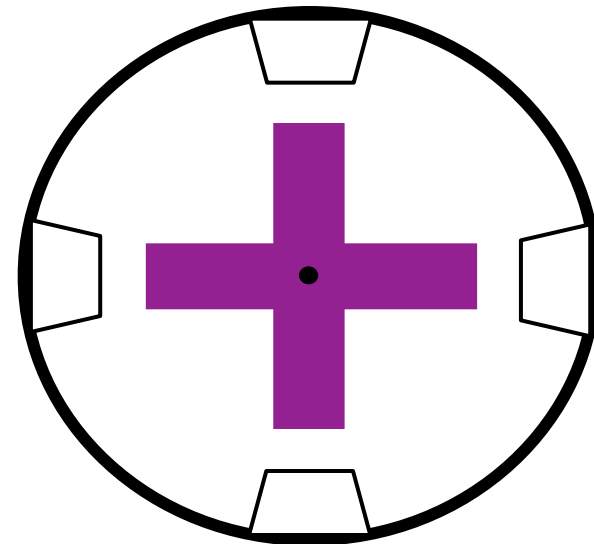

Increased Resolution

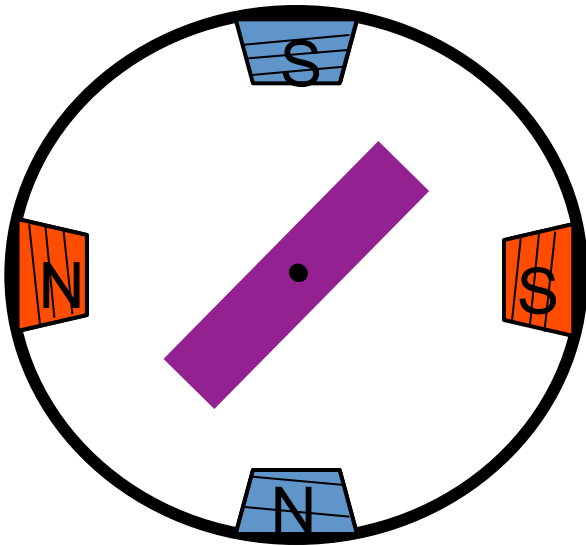

Half stepping

More teeth on rotor or stator

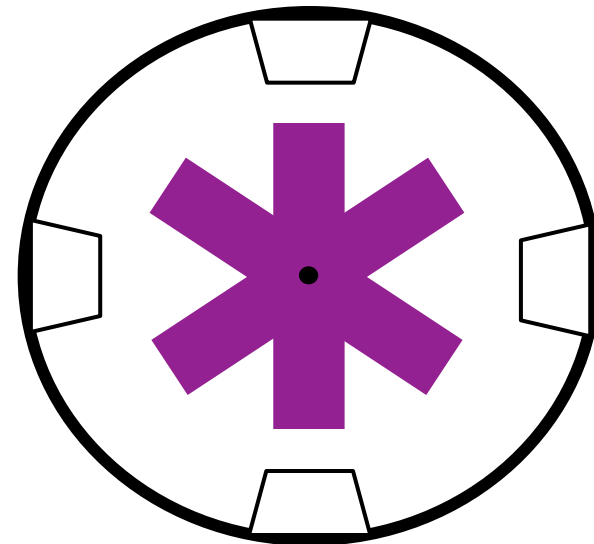

More Teeth on Rotor

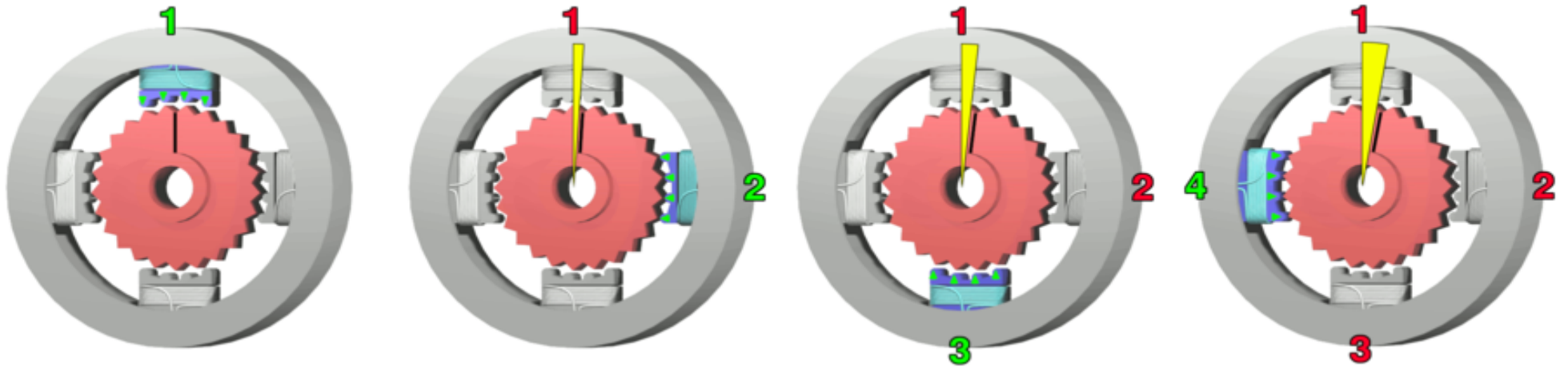

Stepper Motors

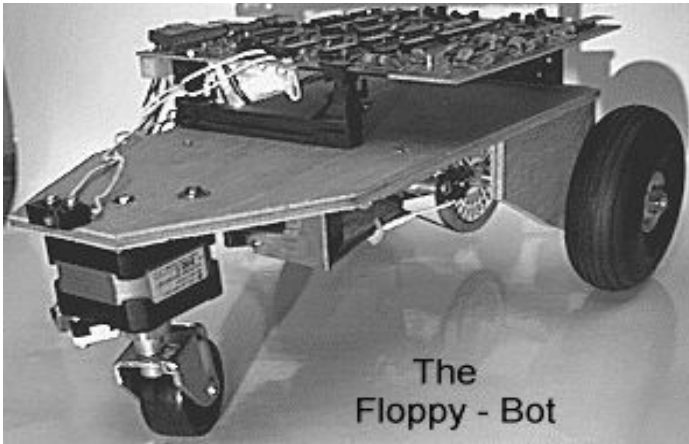

- Pros:
 - Direct position control
 - Precise positioning
 - Easy to control

- Cons:
 - Oscillations
 - Low torque at high speeds



DC motors -- exposed !

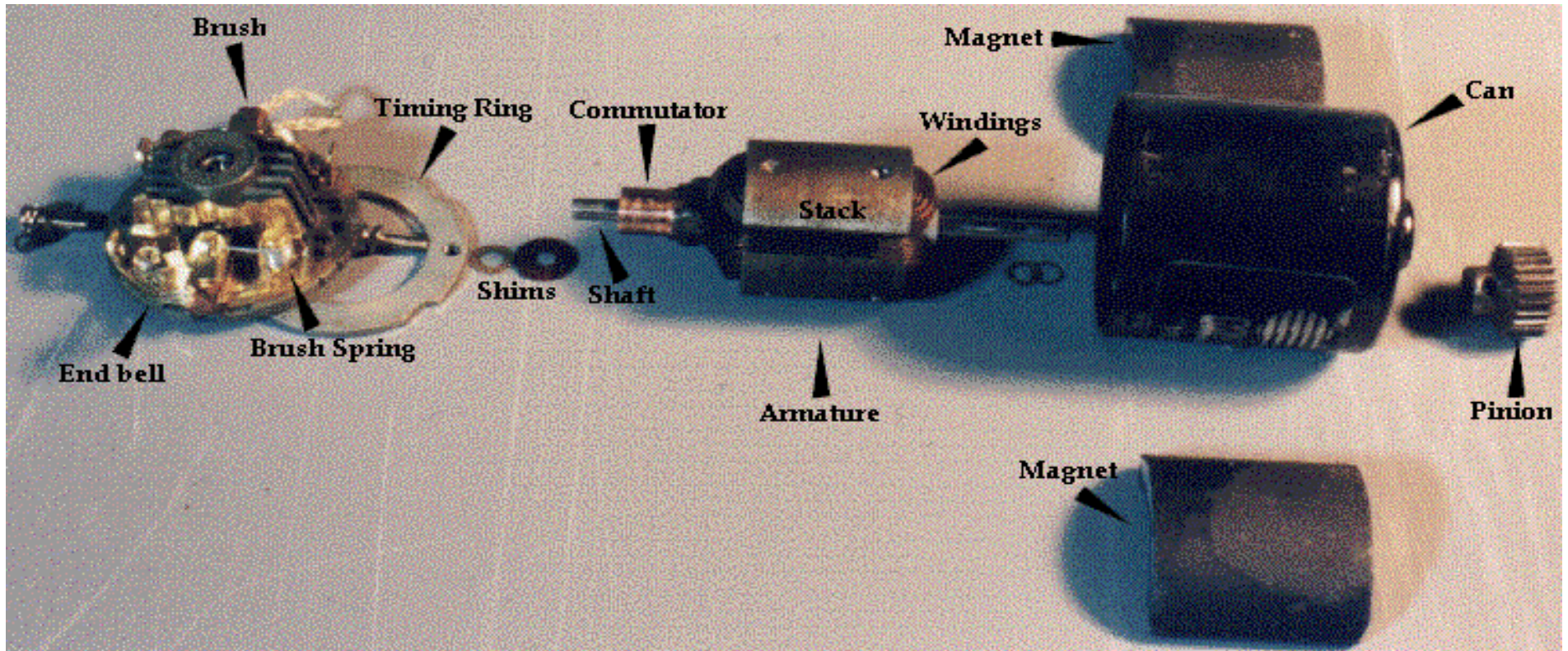

DC motor basics

permanent magnets

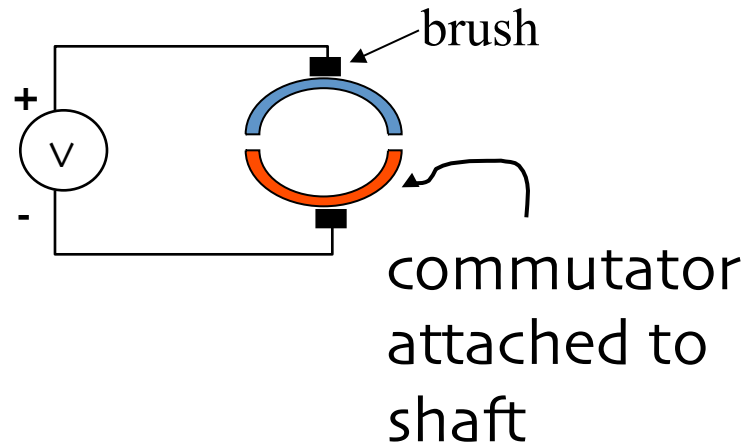
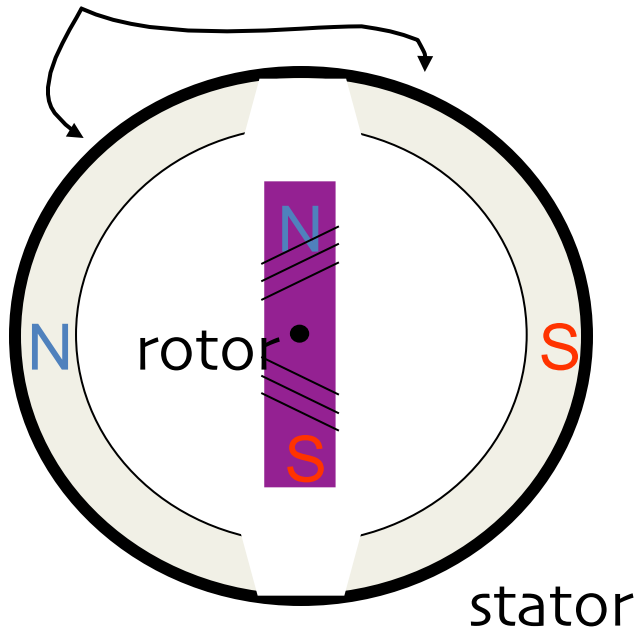

DC motor basics

permanent magnets

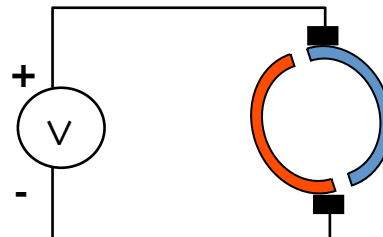
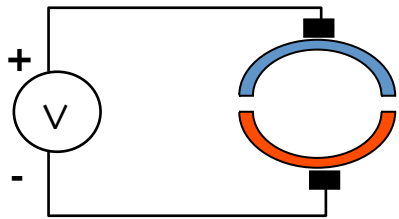
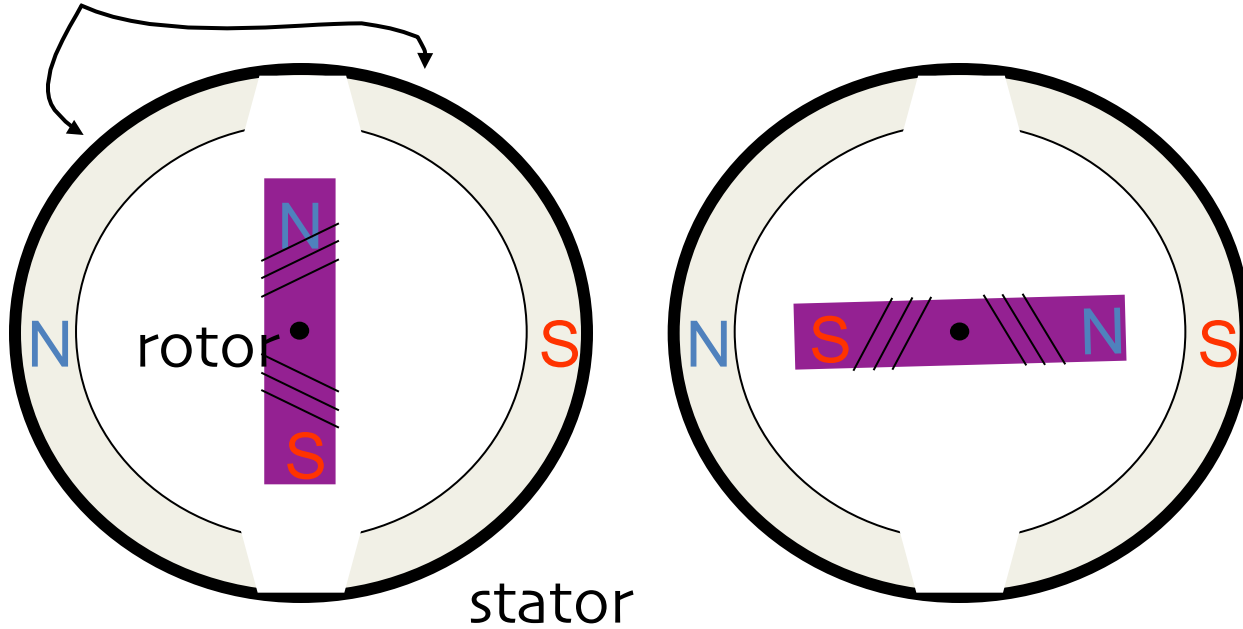

DC motor basics

permanent magnets

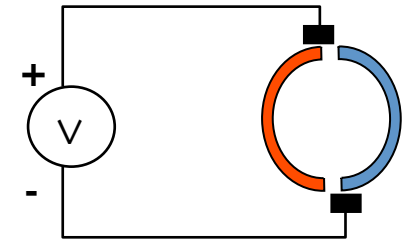
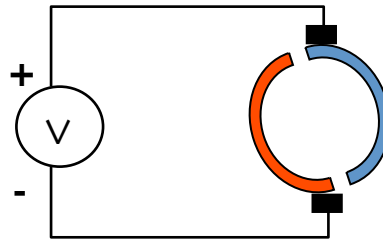
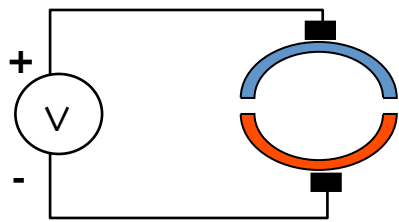
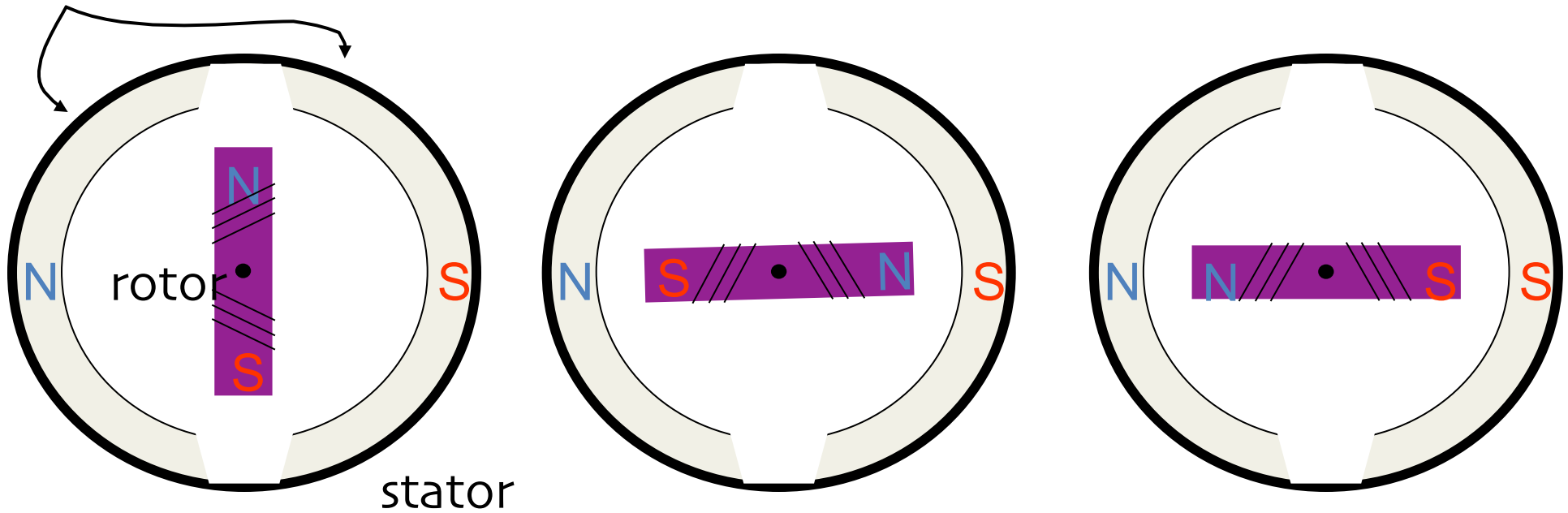

DC motor torque τ

τ = torque

I = current

$$\tau \propto I$$

